

**TECHNICAL MANUAL
OPERATOR'S, UNIT, AND DIRECT SUPPORT
MAINTENANCE MANUAL**

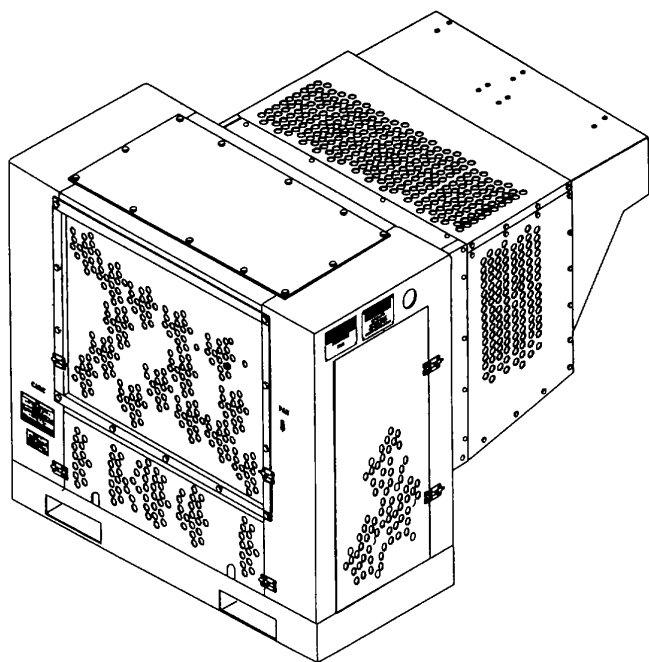

**REFRIGERATION UNIT, MECHANICAL,
9K BTU, ELECTRIC
MODEL F9000RE**

(4110-01-394-6473)

OPERATING INSTRUCTIONS	2-1
OPERATOR PREVENTIVE MAINTENANCE CHECKS AND SERVICES (PMCS)	2-6
UNIT MAINTENANCE INSTRUCTIONS	4-1
UNIT PREVENTIVE MAINTENANCE CHECKS AND SERVICES (PMCS)	4-8
UNIT TROUBLESHOOTING	4-23
DIRECT SUPPORT MAINTENANCE INSTRUCTIONS	5-1
MAINTENANCE ALLOCATION CHART	B-1

DISTRIBUTION STATEMENT A: Approved for public release; distribution is unlimited.

**HEADQUARTERS, DEPARTMENT OF THE ARMY
19 JANUARY 1996**

WARNING

- High voltage and exposed rotating parts are contained in the refrigeration unit. Personal injury can result if access doors are open when power is connected.
- Dangerous chemical refrigerant under pressure is used in the refrigeration unit. Sudden and irreversible tissue damage can result from contact with liquid refrigerant. When exposed to high heat or flame, irritating, toxic, and corrosive gases may be released. Wear gloves and a face protector or safety glasses in any situation where skin or eye contact with refrigerant is possible. Do not allow refrigerant to come in contact with high heat or flame. All refrigerant must be discharged from the system and the entire system must be purged with dry nitrogen before beginning any brazing operation.
- Do not attempt any disassembly of refrigerant system components with a refrigerant charge in the system. Refrigerant will be sprayed out dangerously.
- Never introduce high discharge pressure into a refrigerant cylinder. This can cause the cylinder to rupture and injure personnel.
- Never pressurize refrigerant lines with oxygen, mixture with oil could cause an explosion.
- Nitrogen is an inert gas that can cause suffocation and must be discharged in a well ventilated area.
- The pressure in a nitrogen cylinder can exceed 2000 psi. A nitrogen pressure regulator should be used at all times to avoid personal injury.
- Acetone and methyl-ethyl ketone (MEK) are flammable and their vapors can be explosive. Repeated or prolonged skin contact or inhalation of vapors can be toxic. Use in a well ventilated area, wear gloves, and keep away from sparks or flame.
- Solder, brazing alloys, and flux contain materials which are hazardous to health. Avoid breathing vapors or fumes from soldering or brazing operations. Perform operations only in well-ventilated areas. Wash hands with soap and water after handling solder, brazing alloys, or flux. Wear thermal gloves and protective goggles or face shield to protect against burns.
- Compressor lubricating oil is caustic. Wear gloves and a face protector or safety glasses in any situation where skin or eye contact is possible. If oil does contact skin, wash with soap and water.

CHANGE
NO. 1

HEADQUARTERS
DEPARTMENT OF THE ARMY
WASHINGTON, DC, 30 SEPTEMBER 2005

TECHNICAL MANUAL

OPERATOR'S, UNIT AND DIRECT SUPPORT MAINTENANCE MANUAL

FOR
REFRIGERATION UNIT, MECHANICAL,
9K BTU, ELECTRIC MODEL F9000RE

NSN: 4110-01-394-6473

DISTRIBUTION STATEMENT A: Approved for public release; distribution is unlimited.

TM 9-4110-258-13, dated 19 January 1996, is changed as follows:

1. File this sheet in the front of the manual for reference.
2. This change implements Army Maintenance Transformation and changes the Maintenance Allocation Chart (MAC) to support Field and Sustainment Maintenance.
3. New or updated text is indicated by a vertical bar in the outer margin.
4. Added illustrations are indicated by a vertical bar adjacent to the figure number. Changed illustrations are indicated by a miniature hand adjacent to the updated area and a vertical bar adjacent to the figure number.
5. Remove old pages and insert new pages as indicated below:

Remove Pages

B-1 – B-10
Electronic 2028 Instructions
2028

Insert Pages

A/(B blank)
B-1 – B-8
Electronic 2028 Instructions/blank
Sample 2028 – Front/Back
2028 – Front/Back
2028 – Front/Back

TM 9-4110-258-13
C1

By Order of the Secretary of the Army:

PETER J. SCHOOMAKER
General, United States Army
Chief of Staff

Official:

Sandra R. Riley
SANDRA R. RILEY
*Administrative Assistant to the
Secretary of the Army*
0525506

Distribution: To be distributed in accordance with initial distribution number (IDN) 256320 requirements for TM 9-4110-258-13.

INSERT LATEST CHANGED PAGES. DESTROY SUPERSEDED PAGES.

LIST OF EFFECTIVE PAGES

NOTE: The portion of text affected by the change is indicated by a vertical line in the outer margins of the page. Changes to illustrations are indicated by shaded or screened areas, or by miniature pointing hands. Zero in the "Change No." column indicates an original page.

Dates of issue for original and changed pages are:

Original .. 0 .. 19 January 1996

Change .. 1 .. 30 September 2005

TOTAL NUMBER OF PAGES IN THIS PUBLICATION IS 308, CONSISTING OF THE FOLLOWING:

Page No.	Change No.
Title	0
a/(b blank)	0
i - viii	0
1-0 - 1-14	0
2-1 - 2-24	0
3-1 - 3-3/(3-4 blank)	0
4-1 - 4-102	0
5-1 - 5-84	0
A-1/(A-2 blank)	0
B-1 - B-8	1
C-1 - C-2	0
D-1/(D-2 blank)	0
E-1 - E-3/(E-4 blank)	0
F-1 - F-21/(F-22 blank)	0
G-1 - G-2	0
Index-1 - Index-3/(Index-4 blank)	0
Back Cover	0

TECHNICAL MANUAL

NO. 9-4110-258-13

HEADQUARTERS
DEPARTMENT OF THE ARMY
WASHINGTON, D.C., 19 January 1996

OPERATOR'S, UNIT, AND DIRECT SUPPORT
MAINTENANCE MANUAL
FOR
REFRIGERATION UNIT, MECHANICAL,
9K BTU, ELECTRIC
MODEL F900ORE
4110-01-394-6473

REPORTING ERRORS AND RECOMMENDING IMPROVEMENTS

You can help improve this manual. If you find any mistakes, or if you know of a way to improve these procedures, please let us know. Mail your letter or DA Form 2028 (Recommended Changes to Publications and Blank Forms), or DA Form 2028-2 located in the back of this manual directly to: Commander, US Army Aviation and Troop Command, ATTN: AMSAT-I-MP, 4300 Goodfellow Blvd., St. Louis, MO 63120-1798. You may also submit your recommended changes by E-mail directly to <mpmt%avma28st-louis-emh7.army.mil>. A reply will be furnished directly to you. Instructions for sending an electronic 2028 may be found at the back of this manual immediately preceding the hard copy 2028.

DISTRIBUTION STATEMENT A: Approved for public release; distribution is limited.

	Page
CHAPTER 1	INTRODUCTION 1-1
Section I	General Information..... 1-1
Section II	Equipment Description..... 1-2
Section III	Principles of Operation 1-6
CHAPTER 2	OPERATING INSTRUCTIONS 2-1
Section I	Description and Use of Operator's Controls and Indicators..... 2-1
Section II	Preventive Maintenance Checks and Services 2-6
Section III	Operation Under Usual Conditions 2-19
Section IV	Operation Under Unusual Conditions 2-24

TABLE OF CONTENTS - Continued

	Page
CHAPTER 3	OPERATOR MAINTENANCE INSTRUCTIONS 3-1
Section I	Lubrication..... 3-1
Section II	Troubleshooting Procedures 3-1
Section III	Operator's Maintenance Procedures 3-3
CHAPTER 4	UNIT MAINTENANCE INSTRUCTIONS 4-1
Section I	Lubrication Instructions 4-1
Section II	Repair Parts, Tools, Special Tools, Test, Measurement, and Diagnostic Equipment (TMDE), and Support Equipment 4-1
Section III	Service Upon Receipt 4-1
Section IV	Unit Preventive Maintenance Checks and Services (PMCS)..... 4-8
Section V	Unit Troubleshooting Instructions..... 4-23
Section VI	Unit Maintenance Instructions 4-28
Section VII	Preparation for Storage or Shipment 4-102
CHAPTER 5	DIRECT SUPPORT MAINTENANCE INSTRUCTIONS 5-1
Section I	Direct Support Troubleshooting Instructions..... 5-1
Section II	Direct Support Maintenance Procedures..... 5-2
APPENDIX A	REFERENCES A-1
APPENDIX B	MAINTENANCE ALLOCATION CHART B-1
Section I	Introduction..... B-1
Section II	Maintenance Allocation Chart for Refrigeration Unit B-5
Section III	Tools and Test Equipment for Refrigeration Unit..... B-9
Section IV	Remarks for Refrigeration Unit B-10
APPENDIX C	COMPONENTS OF END ITEM (COEI) AND BASIC ISSUE ITEMS LIST C-1
Section I	Introduction C-1
Section II	Components of End Item C-1
Section III	Basic Issue Items List C-2

TABLE OF CONTENTS - Continued

	Page
APPENDIX D	ADDITIONAL AUTHORIZATION LISTD-1
APPENDIX E	EXPENDABLE AND DURABLE ITEMS LIST E-1
Section I	Introduction E-1
Section II	Expendable and Durable Items List E-2
APPENDIX F	ILLUSTRATED LIST OF MANUFACTURED ITEMS.: F-1
Section I F-1
Section II F-2
APPENDIX G	MANDATORY REPLACEMENT PARTS..... G-1
GLOSSARY Glossary-1
Section I	Abbreviations Glossary-1
Section II	Definition of Unusual Terms Glossary-1
ALPHABETICAL INDEX.....	Index-1

LIST OF ILLUSTRATIONS

Figure	Title	Page
1-0	Refrigeration Unit	1-0
1-1	Major Components.....	1-4
1-2	Electrical System	1-7
1-3	Electrical Schematic	1-8
1-4	Electrical Wiring Diagram.....	1-9
1-5	Refrigeration System.....	1-12
1-6	Refrigeration Schematic.....	1-13
1-7	Air Flow.....	1-14
2-1	Operating Controls and Indicators	2-3
2-2	Fault Controls and Indicators.....	2-5
2-3	Operator's PMCS Routing Diagram	2-7
2-4	Operating Controls and Indicators	2-20
2-5	Decals and Instruction Plates	2-22
4-1	Wall Opening Dimensions	4-2
4-2	Installation.....	4-3
4-3	Input Power Cable.....	4-4
4-4	Refrigeration Valve Setting for Normal Operation	4-5
4-5	Compressor Mount.....	4-6
4-6	Preliminary Adjustment	4-7
4-7	Lubrication	4-8
4-8	Top Access Panel	4-28
4-9	Top Panel	4-29
4-10	Side Panels	4-31
4-11	Condenser Coil Guard	4-33
4-12	Wire Cables and Harnesses	4-35
4-13	Indicator/Lamp	4-41
4-14	Toggle Switch	4-43
4-15	Hour meter.....	4-45
4-16	Circuit Breaker	4-47
4-17	Thermostat.....	4-49
4-18	Fuses	4-53
4-19	Motor Starter.....	4-55
4-20	Contactors	4-58
4-21	Contactors	4-60
4-22	Control Relays	4-62
4-23	Defrost Timer	4-64
4-24	Push Switches	4-67
4-25	V-Belt.....	4-70
4-26	Pulley.....	4-71
4-27	Sheave	4-73
4-28	AC Motor.....	4-75
4-29	Flange Bearings.....	4-77

LIST OF ILLUSTRATIONS - Continued

Figure	Title	Page
4-30	Condenser Fan	4-79
4-31	Evaporator Fan	4-80
4-32	Solenoid Valve (Liquid Line)	4-83
4-33	Solenoid Valve (Defrost Line).....	4-85
4-34	Thermometer	4-87
4-35	Electric Heaters.....	4-90
4-36	Thermostatic Switch.....	4-92
4-37	Temperature Switch	4-95
4-38	Gasket	4-97
4-39	Barrel Bolts	4-99
4-40	Refrigeration System Pump Down.....	4-101
4-41	Compressor Mount	4-102
5-1	Control Box Cover.....	5-3
5-2	Circuit Breaker Cover.....	5-5
5-3	Fan Drive Shaft	5-7
5-4	Service Manifold Installation	5-9
5-5	Discharging Refrigerant.....	5-12
5-6	Nitrogen Tank Connection	5-14
5-7	Evacuation of Refrigerant System	5-20
5-8	Refrigerant Charging (Total System)	5-23
5-9	Refrigerant Charging (Partial System/Small Quantity Charge)	5-25
5-10	Dehydrator	5-30
5-11	Strainer	5-32
5-12	Isolation Valves.....	5-34
5-13	Receiver	5-37
5-14	Pressure Regulator Valve (Discharge).....	5-38
5-15	Pressure Regulator Valve (Crankcase).....	5-40
5-16	Check Valve	5-41
5-17	Metal Hose Assembly (Discharge).....	5-43
5-18	Metal Hose Assembly (Suction)	5-44
5-19	Accumulator.....	5-46
5-20	Solenoid Valve (Liquid Line).....	5-48
5-21	Solenoid Valve (Defrost Line).....	5-50
5-22	Stop Valve (Liquid Line).....	5-51
5-23	Stop Valve (Defrost Line)	5-52
5-24	Sight Indicator	5-54
5-25	Condenser Coil	5-56
5-26	Tubing And Fittings	5-58
5-27	Differential Oil Pressure Switch.....	5-60
5-28	Dual Pressure Control Switch.....	5-63
5-29	Pressure Gauge (Low).....	5-65
5-30	Pressure Gauge (High).....	5-66
5-31	Heat Exchanger	5-68
5-32	Expansion Valve	5-71
5-33	Evaporator Coil	5-73
5-34	Compressor	5-77

LIST OF ILLUSTRATIONS --Continued

Figure	Title	Page
C-1	Basic Issue Items	C-2
F-1	Tube, Copper Straight, Various	F-4
F-2	Tubing Copper, Straight Flared, Various.....	F-4
F-3	Tube, Receiver to Filter Drier, Part Number 151K0052-1	F-5
F-4	Gasket, Control Box, Part Number 152K0036	F-6
F-5	Gasket, Control Box, Side, Part Number 152K0037	F-6
F-6	Gasket, Part Number 152K0116.....	F-6
F-7	Gasket, Circuit Breaker Panel, Part Number 152K0117.....	F-7
F-8	Gasket, Inside, Right/Left Side, Part Number 152K0158-1 & -2.....	F-7
F-9	Gasket, Outside, Top/Bottom, Part Number 152K0159	F-7
F-10	Gasket, Outside, Right/Left Side, Part Number 152K0160	F-8
F-11	Gasket, Inside, Top/Bottom, Part Number 152K0161	F-8
F-12	Tube Assembly, Outlet, Condenser Coil, Part Number 152K0171	F-9
F-13	Tube Assembly, Outlet, Solenoid Valve (Liquid Line), Part Number 152K0172.....	F-10
F-14	Tube, Outlet, Sight Glass, Part Number 152K0173.....	F-11
F-15	Tube, Outlet, Heat Exchanger, Part Number 152K0174	F-11
F-16	Tube, Outlet, Accumulator, Part Number 152K0175	F-12
F-17	Tube, Outlet, Vibration Isolator (Suction Line), Part Number 152K0176.....	F-12
F-18	Tube, Outlet, Vibration Isolator (Discharge Line), Part Number 152K0177.....	F-13
F-19	Tube, Outlet, Discharge Pressure Regulator Valve, Part Number 152K0178.....	F-13
F-20	Tube Assembly, Outlet, Strainer, Part Number 152K0179.....	F-14
F-21	Tube, Header to Elbow, Part Number 152K0193	F-14
F-22	Contact Cradle, Sensing Bulb, Part Number 152K0194.....	F-14
F-23	Tube, Heat Exchanger to Tube, Part Number 152K0195.....	F-15
F-24	Tube, Tube to Expansion Valve, Part Number 152K0196	F-16
F-25	Tube Equalizer Line, Part Number 152K0197.....	F-16
F-26	Tube, Tee to Distributor, Part Number 152K0198	F-17
F-27	Grommet, Part Number 500K1662-2-11.33	F-17
F-28	Tubing, Insulation, Part Number 152)000D-1/57	F-18
F-29	Tubing, Tygon, Part Number 152KO000-1/155.....	F-18
F-30	Insulation Sound and Temperature, Part Number 152K000-1/172	F-18
F-31	Insulation Sleeving	F-19
F-32	Tube Assembly, Outlet, Handvalve To Sight Glass, Part Number 152K0180-1	F-19
F-33	Tube Assembly, Outlet, Solenoid Valve (Defrost Line), Part Number 152K0182-1.....	F-20
F-34	Tube, Heat Exchanger To Elbow, Part Number 152K0192	F-20
F-35	Tube Assembly, Outlet Receiver To Dehydrator, Part Number 152K1(0205-1	F-21

LIST OF TABLES

Table	Title	Page
2-1	Operator Preventive Maintenance Checks and Services.....	2-8
4-1	Preventive Maintenance Checks and Services for Model F9000RE	4-11
4-2	Monthly Mandatory Replacement Parts.....	4-23
4-3	Semi-Annually Mandatory Replacement Parts.....	4-23
4-4	Wire List	4-37
5-1	Pressure Temperature Relationship of Saturated Refrigerant R-134a.....	5-28
5-2	Nominal Operating Pressure At Suction And Discharge Shut Off Valves.....	5-29

HOW TO USE THIS MANUAL

Be sure to read all Warnings before using this equipment.

This manual contains instructions for operation and maintenance of the Refrigeration Unit. The front cover index of this manual lists the areas of the manual used most often and guides you to those sections.

Follow the black mark on the cover index edge through the pages to the edge mark on the section you want. A detailed alphabetical index is located at the back of the manual.

Chapter 1 - Provides general information, technical description of the equipment, and principles of operation.

Chapter 2 - Provides complete operating instructions for the equipment. These instructions include identification of controls and indicators, preventive maintenance required, checks and services required, and specialized instructions for abnormal operating conditions.

Chapter 3 - Provides operator level troubleshooting and maintenance procedures for the equipment.

Chapter 4 - Provides unit maintenance level procedures for receiving and installing the equipment, preparing it for operation, preventive maintenance required, checks and services required, troubleshooting and maintenance procedures, and information to prepare the equipment for short or long term storage and shipment.

Chapter 5 - Provides direct support maintenance level troubleshooting and maintenance procedures for the equipment.

Appendix A - Provides a list of frequently used forms and publications referenced or used in this manual.

Appendix B - Identifies repairable components and the maintenance level authorized to perform the repairs.

Appendix C - Lists any loose components that are part of the equipment and any other basic items required.

Appendix D - Lists any additional items authorized for the support of the equipment.

Appendix E - Lists the expendable and durable materials needed to operate and maintain the equipment.

Appendix F - Provides information to make any item authorized to be manufactured or fabricated to maintain the equipment.

Appendix G - Lists all hardware or component parts that cannot be used again after being removed from the equipment.

Glossary - Lists acronyms, unusual terms, and abbreviations with their definitions as used in this manual.

Alphabetical Index - Lists the paragraphs contained within this manual in alphabetical order with their paragraph numbers.

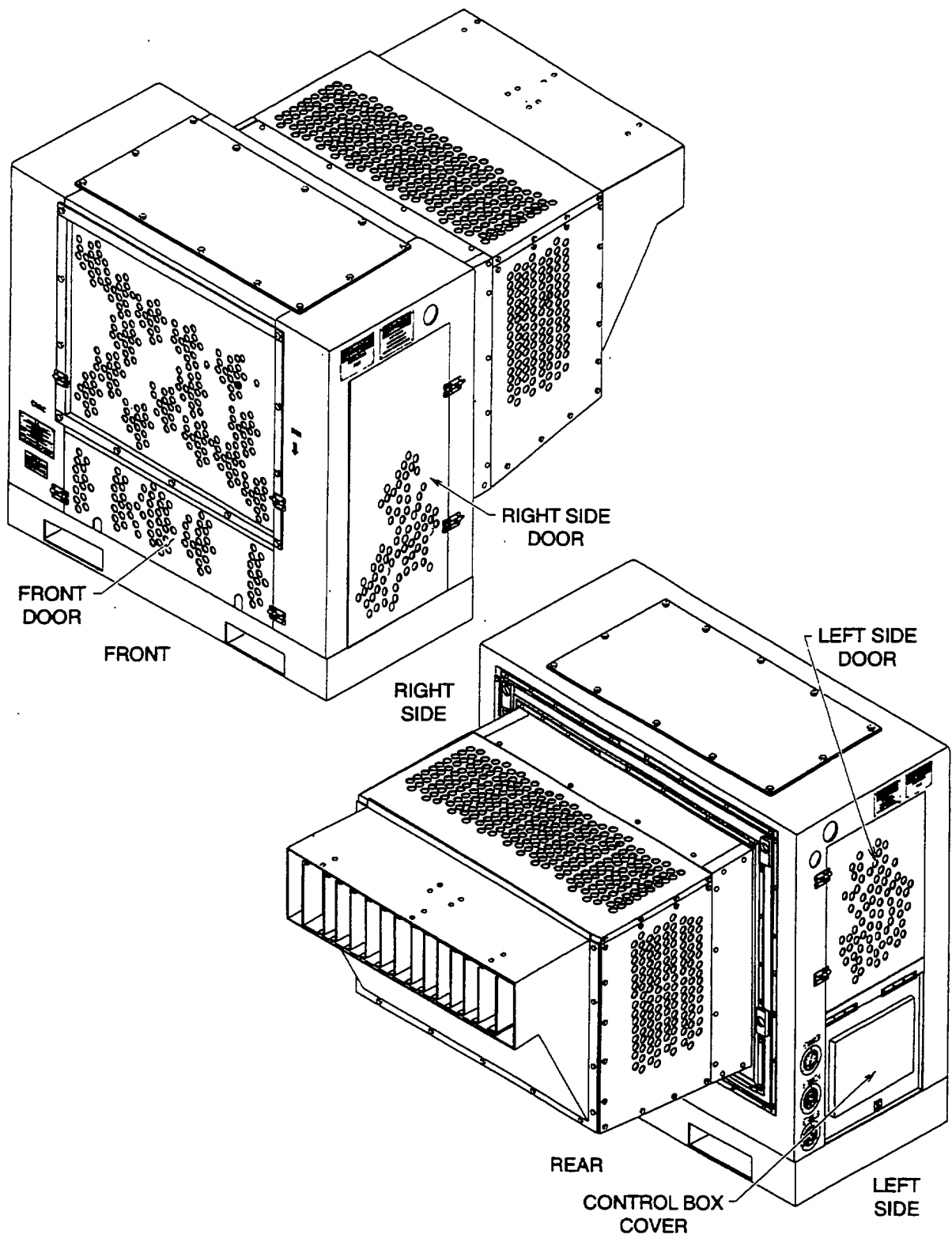

Figure 1-0. Refrigeration Unit

CHAPTER 1

INTRODUCTION

SECTION I GENERAL INFORMATION

1.1 SCOPE.

1.1.1 Type of Manual. Operator's, Unit, and Direct Support Maintenance Manual.

1.1.2 Model Number and Equipment Name. Model F9000RE, Mechanical, Electric motor driven, 9,000 btu per hour Refrigeration Unit.

1.1.3 Purpose of Equipment. The refrigeration unit is intended for worldwide military use in the field and at sea under adverse climatic and operating conditions without protection from the elements. The units are designed to automatically control the interior temperature of an eight foot by eight foot by twenty foot long insulated container with both cooling and heating. In use, the units are mounted with evaporator section extending into the opening provided in military refrigerated containers.

1.2 MAINTENANCE FORMS. RECORDS AND REPORTS.

Department of the Army forms and procedures used for equipment maintenance will be those prescribed by DA Pam 738-750, The Army Maintenance Management System.

1.3 DESTRUCTION OF ARMY MATERIAL TO PREVENT ENEMY USE.

Refer to TM 750-244-3 for specific instruction on the destruction of army material to prevent enemy use.

1.4 PREPARATION FOR STORAGE OR SHIPMENT.

Refer to Chapter 4 for specific information under the same heading.

1.5 QUALITY ASSURANCE.

Requirement for specific quality assurance steps are not applicable to this equipment.

1.6 NOMENCLATURE CROSS-REFERENCE LIST. A shortened nomenclature is used in this manual to make procedures easier for you to read. A cross-reference between the shortened nomenclature and the official nomenclature is shown in the following table.

Manual Nomenclature	Official Nomenclature
Refrigeration Unit	Refrigeration Unit, Mechanical, 9K btu, Electric, Model F9000RE
Refrigerator Enclosure	Prefabricated Panel Type Refrigerator

1.7 REPORTING EQUIPMENT IMPROVEMENT RECOMMENDATIONS (EIR).

If your refrigeration unit needs improvement, let us know. Send us an EIR. You, the user, are the only one who can tell us what you don't like about your equipment. Let us know why you don't like the design or performance. Put it on an SF 368 (Product Quality Deficiency Report). Mail it to:

Commander

US. Army Aviation and Troop Command

ATTN: AMSAT-I-MDO

4300 Goodfellow Blvd.

St. Louis, MO 63120-1798

1.8 WARRANTY INFORMATION.

Refer to TB 9-4110-25823 for specific warranty information.

1.9 CORROSION PREVENTION AND CONTROL.

1.9.1 Corrosion Prevention and Control (CPC) of Army material is a continuing concern. It is important that any corrosion problems with this item be reported so that the problem can be corrected and improvements can be made to prevent the problem in future items.

1.9.2 While corrosion is typically associated with rusting of metals, it can also include deterioration of other materials, such as rubber and plastic. Unusual cracking, softening, swelling, or breaking of these materials may be a corrosion problem.

1.9.3 If a corrosion problem is identified, it can be reported using Standard Form 368, Product Quality Deficiency Report. Use of keywords such as "corrosion," "rust," "deterioration," or "cracking" will ensure that the information is identified as a CPC problem.

1.9.4 The form should be submitted to the address specified in DA Pam 738-750.

SECTION II EQUIPMENT DESCRIPTION

1.10 EQUIPMENT CHARACTERISTICS. CAPABILITIES AND FEATURES.

1.10.1 Characteristics. The Keco Model F900RE, is a self-contained, refrigeration/heating unit for military van containers. The unit is designed to allow for starting and operating on a 10 KW, 60 hertz generator set.

1.10.2 Capabilities. The unit is capable of starting and operating in ambient temperature from 0° F to 125° F.

1.10.3 Features. The unit is designed to use R134a refrigerant. The portion of the condensing unit exposed to the weather can operate in rainfall of 3 inches per hour minimum without functional damage or impairment of operation. It can automatically control both cooling and heating the container and automatically switching from cooling to heating and heating to cooling. The unit can operate on a 50 Hz power source with a voltage range of 180 to 230 volts and on a 60 Hz power source with a voltage range of 200 to 250 volts.

1.11 LOCATION AND DESCRIPTION OF MAJOR COMPONENTS.

- 1 CONTROL BOX ASSEMBLY. Houses the automatic and manual electrical control components.
- 2 EVAPORATOR COIL. Absorbs heat from the air being circulated through the refrigerator enclosure causing the low pressure liquid refrigerant in the coil to evaporate.
- 3 COMPRESSOR. Moves the refrigerant through the refrigeration system by raising the pressure of the incoming gas from the evaporator coil and discharging it as a high pressure gas.
- 4 CONDENSER COIL. Releases heat from the high pressure gas coming from the compressor causing the gas to condense into a high pressure liquid.
- 5 AC MOTOR. Drives the air handling components.
- 6 EVAPORATOR FAN. Circulates air through the refrigerator and across the evaporator coil.
- 7 CONDENSER FAN. Circulates ambient, outside air across the condenser coil.
- 8 DUAL PRESSURE CONTROL SWITCH. Provides over/under pressure protection for the refrigeration system. The switch has an automatic reset for overpressure conditions.
- 9 DIFFERENTIAL OIL PRESSURE SWITCH. Provides protection against loss of lubricating oil in the compressor. The switch has a manual reset for low oil conditions.
- 10 ELECTRIC HEATER. Heats the air being circulated through the refrigerator enclosure in low ambient temperature conditions.

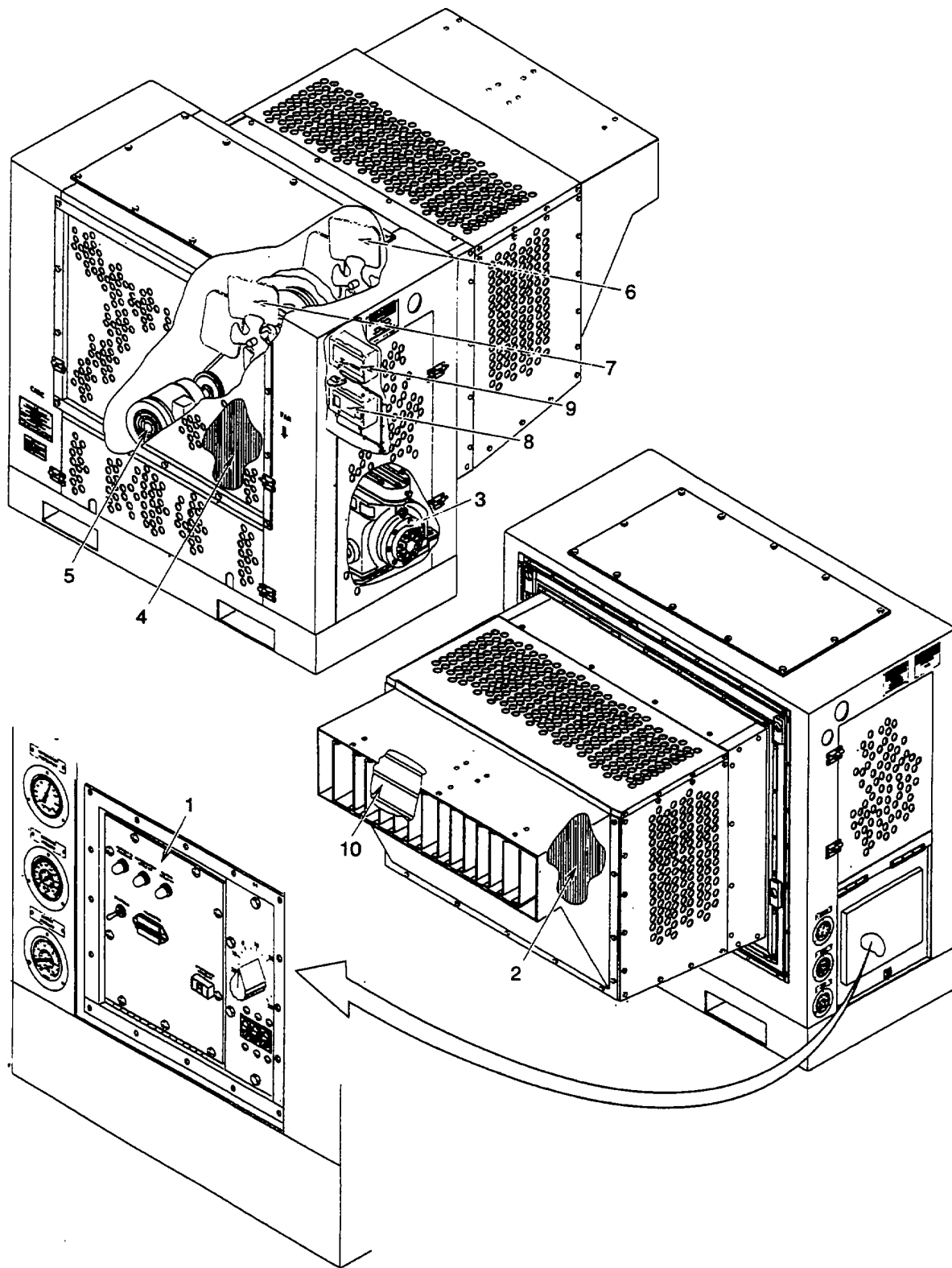

Figure 1-1. Major Components

1.12 EQUIPMENT DATA.

WEIGHTS AND DIMENSIONS

Weight 1000 lb (454 Kg)

Width 50 in. (127 cm)

Height 46 in. (117 cm)

Depth 54 in. (137 cm)

PERFORMANCE

Cooling Capacity

0°F (-18 C) 10,000 btuh

40° F (4° C) 17,000 btuh

Heating Capacity

40° F (-40° C) 8,000 btuh

ELECTRICAL CHARACTERISTICS

Voltage 200-230 Vac

Frequency 50/60 Hz

Current

Cooling 20 amp

Heating 7 amp

FLUID CAPACITIES

Refrigerant R134a 14 lb (6 Kg)

SECTION III PRINCIPLES OF OPERATION

1.13 ELECTRICAL SYSTEM.

The refrigeration unit requires electrical power to operate. An electrical cable assembly is provided for connection to a source of electrical power. The circuit breaker receives power from the electrical cable assembly and distributes it to the various components and circuits in the control box assembly. The control box assembly houses various automatic and manual components which control the compressor, electrical heaters, and ac motor. The compressor causes refrigerant flow through the refrigeration system, the electric heaters provide heat in low ambient temperature, and the ac motor drives the air handling system.

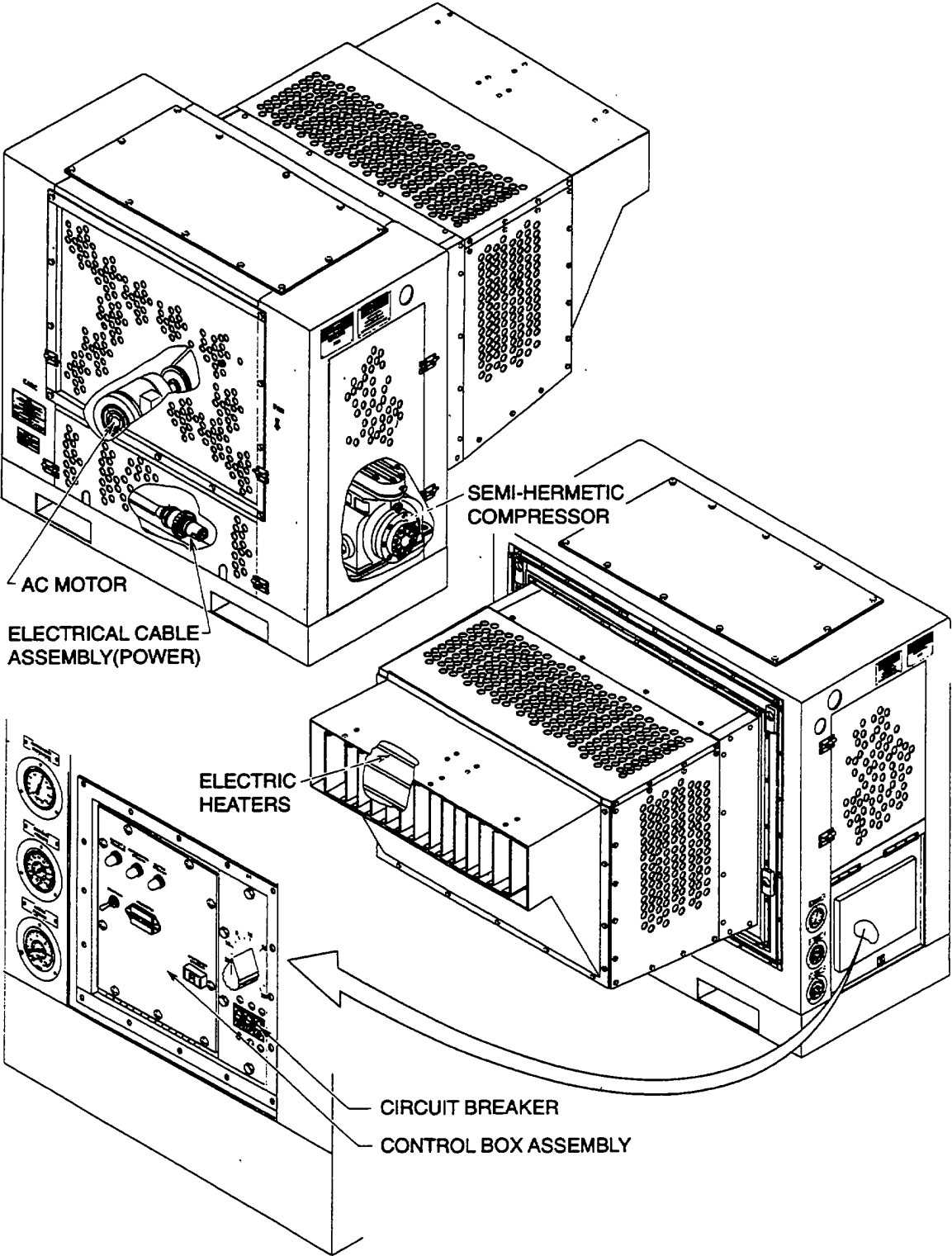
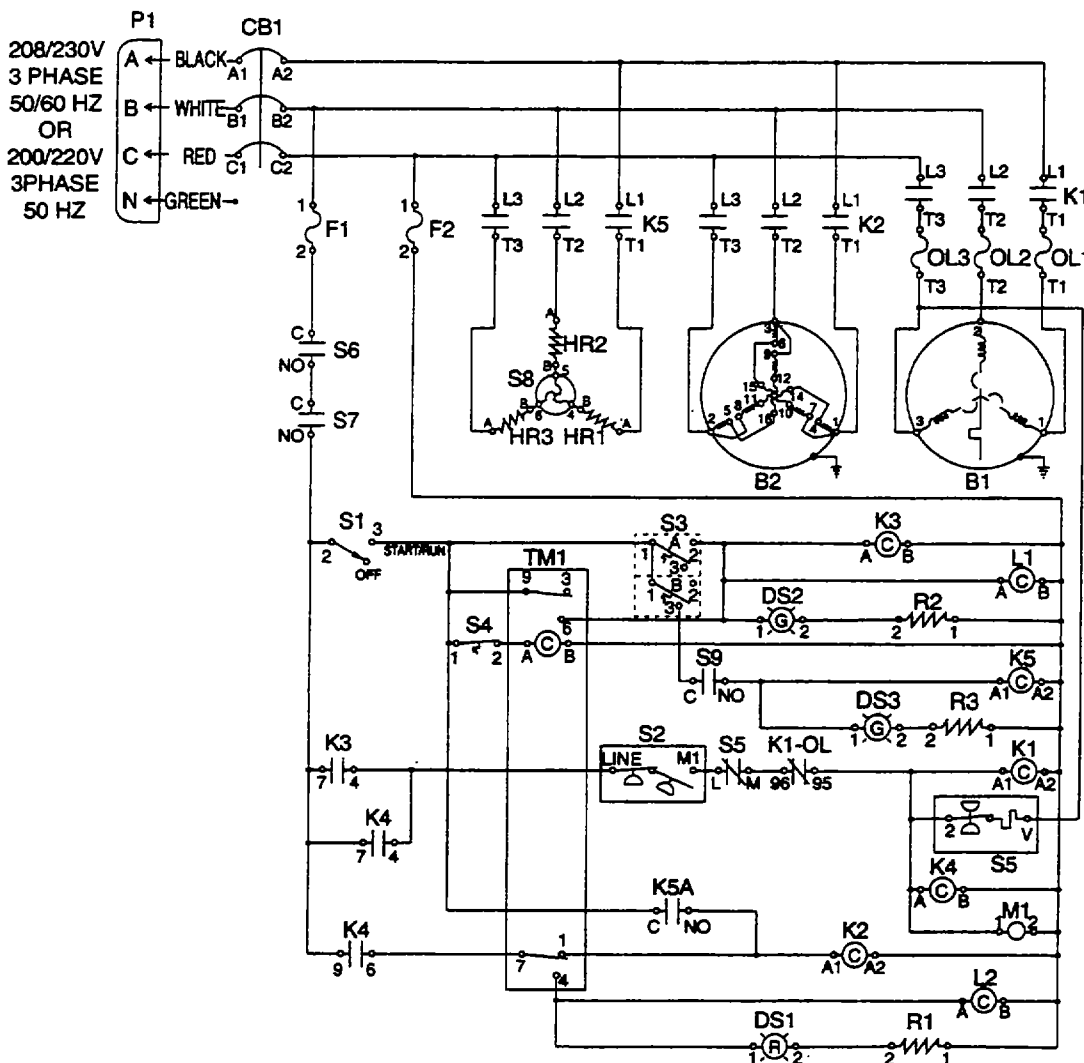

Figure 1-2. Electrical System

1.13 ELECTRICAL SYSTEM. - Continued



LEGEND

ITEM	DESCRIPTION	ITEM	DESCRIPTION
B1	COMPRESSOR, SEMI-HERMETIC	L2	SOLENOID VALVE, NC (DEFROST)
B2	MOTOR, A.C. (FAN)	M1	HOURMETER
CB1	CIRCUIT BREAKER (MAIN)	OL1-3	HEATER, OVERLOAD
DS1	LIGHT, INDICATOR (DEFROST)	P1	PLUG, ELECTRICAL
DS2	LIGHT, INDICATOR (REFRIGERATOR CYCLE)	R1-3	RESISTOR, 10 WATT
DS3	LIGHT, INDICATOR (HEATING CYCLE)	S1	SWITCH, TOGGLE (SELECTOR)
F1,2	FUSE (6 AMP)	S2	SWITCH, REFRIGERANT PRESSURE
HR1-3	HEATING ELEMENT	S3	THERMOSTAT, TEMPERATURE CONTROL
K1	STARTER, MOTOR	S4	SWITCH, TEMP (DEFROST TERMINATION)
K2	RELAY, POWER (FAN)	S5	SWITCH, DIFFERENTIAL OIL PRESSURE
K3,4	RELAY, CONTROL	S6,7	SWITCH, PUSHBUTTON (DOOR)
K5	RELAY, POWER (HEATERS)	S8	THERMOSTAT, HEATER CUTOUT
K5A	AUXILIARY CONTACT	S9	SWITCH, HEATER (LOCKOUT)
L1	SOLENOID VALVE, NC (LIQUID LINE)	TM1	TIMER, DEFROST

Figure 1-3. Electrical Schematic

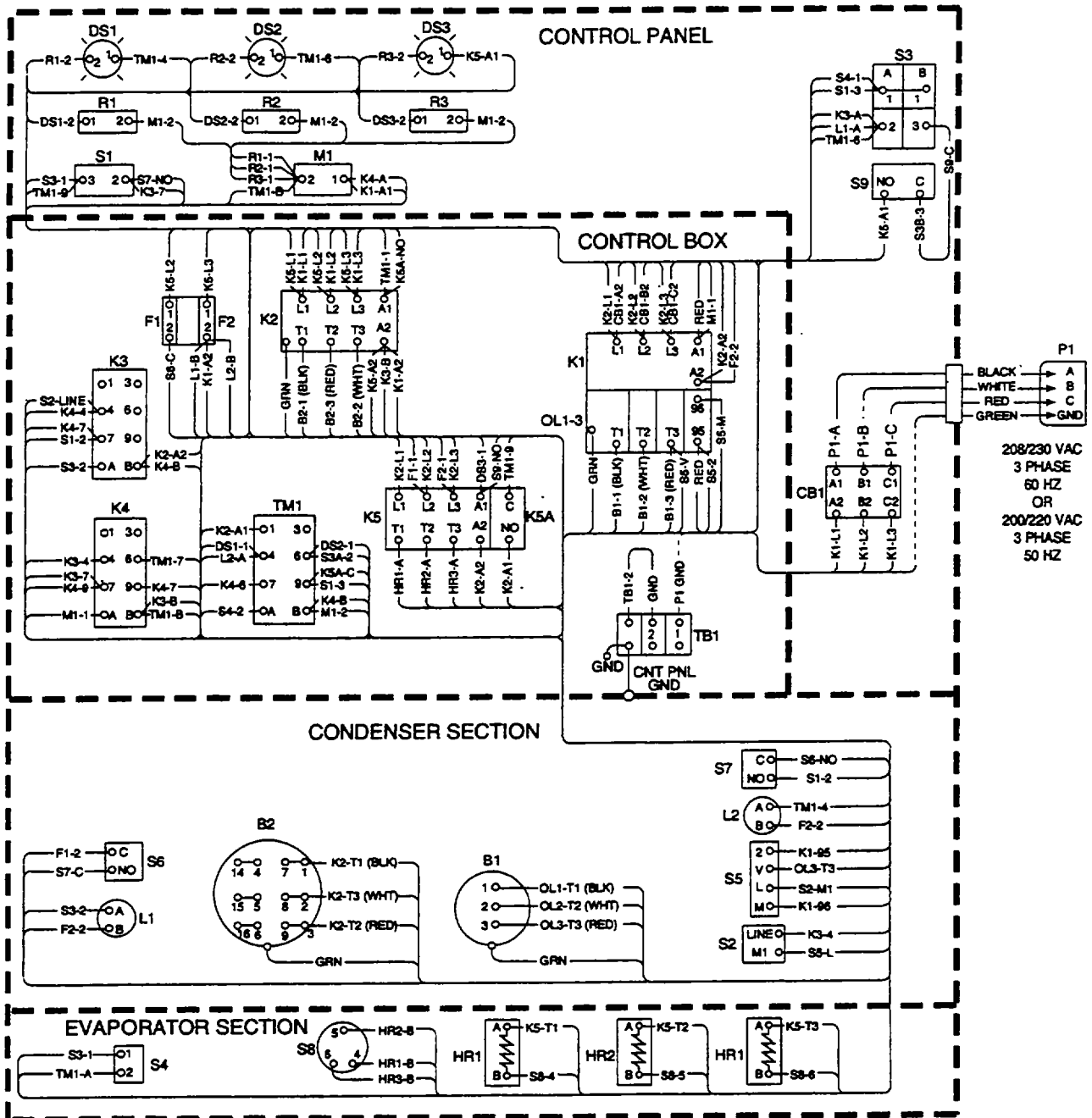

Figure 1-4. Electrical Wiring Diagram (Sheet 1 of 2)

1.13 ELECTRICAL SYSTEM. - Continued

LEGEND			
ITEM	DESCRIPTION	ITEM	DESCRIPTION
B1	COMPRESSOR, SEMI-HERMETIC	L2	SOLENOID VALVE, NC (DEFROST)
B2	MOTOR, A.C. (FAN)	M1	HOURMETER
CB1	CIRCUIT BREAKER (MAIN)	OL1-3	HEATER, OVERLOAD
DS1	LIGHT, INDICATOR (DEFROST)	P1	PLUG, ELECTRICAL
DS2	LIGHT, INDICATOR (REFRIGERATOR CYCLE)	R1-3	RESISTOR, 10 WATT
DS3	LIGHT, INDICATOR (HEATING CYCLE)	S1	SWITCH, TOGGLE (SELECTOR)
F1,2	FUSE (6 AMP)	S2	SWITCH, REFRIGERANT PRESSURE
HR1-3	HEATING ELEMENT	S3	THERMOSTAT, TEMPERATURE CONTROL
K1	STARTER, MOTOR	S4	SWITCH, TEMP (DEFROST TERMINATION)
K2	RELAY, POWER (FAN)	S5	SWITCH, DIFFERENTIAL OIL PRESSURE
K3,4	RELAY, CONTROL	S6,7	SWITCH, PUSHBUTTON (DOOR)
K5	RELAY, POWER (HEATERS)	S8	THERMOSTAT, HEATER CUTOUT
K5A	AUXILIARY CONTACT	S9	SWITCH, HEATER (LOCKOUT)
L1	SOLENOID VALVE, NC (LIQUID LINE)	TB1	TERMINAL BOARD
		TM1	TIMER, DEFROST

Figure 1-4. Electrical Wiring Diagram (Sheet 2 of 2)

1.14 REFRIGERATION SYSTEM.

1.14.1 Cooling Cycle. Heat is absorbed from the refrigerator enclosure and released to the outside ambient air using refrigerant flowing through the refrigeration system. The compressor moves the refrigerant through the refrigeration system by raising the pressure of the incoming gas from the evaporator coil (evaporator) and discharging it as a high pressure gas. The high pressure gas passes through the condenser coil (condenser) when heat is released to the outside ambient air causing the high pressure gas to condense to a high pressure liquid high pressure liquid, which may contain some gas, is collected in the receiver. The receiver contains a dip tube that allows only liquid to flow from it. The high pressure liquid passes through the heat exchanger where it is cooled by low pressure gas returning to the compressor. The high pressure liquid passes through the expansion valve (thermostatic expansion valve) which causes a pressure drop and automatically meters the amount of liquid passing through it. The rapid drop in pressure causes the liquid to cool. The cool, low pressure liquid passes through the evaporator coil where heat is absorbed from the refrigerator enclosure air causing the low pressure liquid to evaporate to a low pressure gas. The low pressure gas passes through the heat exchanger where it absorbs heat from the high pressure liquid going into the expansion valve. The low pressure gas, which may contain some liquid, is collected in the accumulator (suction accumulator). The accumulator separates the low pressure gas from any liquid and allows only gas to flow from it. The low pressure gas returns to the compressor to begin the cycle again.

1.14.2 Defrost Cycle. By lowering the temperature in the refrigerator enclosure to a temperature below freezing, any moisture that accumulates on the evaporator coil will freeze and prevent proper air circulation through the coil. The defrost cycle is automatically controlled by a temperature sensor and electronic timer in the electrical system. The evaporator coil is defrosted when high pressure gas is sent from the compressor directly into the coil. To prevent water from freezing in the evaporator coil drip pan, the warm high pressure gas tubing is routed through the drain hole in the drip pan. The high pressure gas tubing then serpentine across the bottom of the drip pan before entering the coil. The high pressure gas is then returned to the compressor to begin the cycle again. The defrost cycle will continue until either the temperature sensor or electronic timer terminates it.

1.14 REFRIGERATION SYSTEM. -Continued

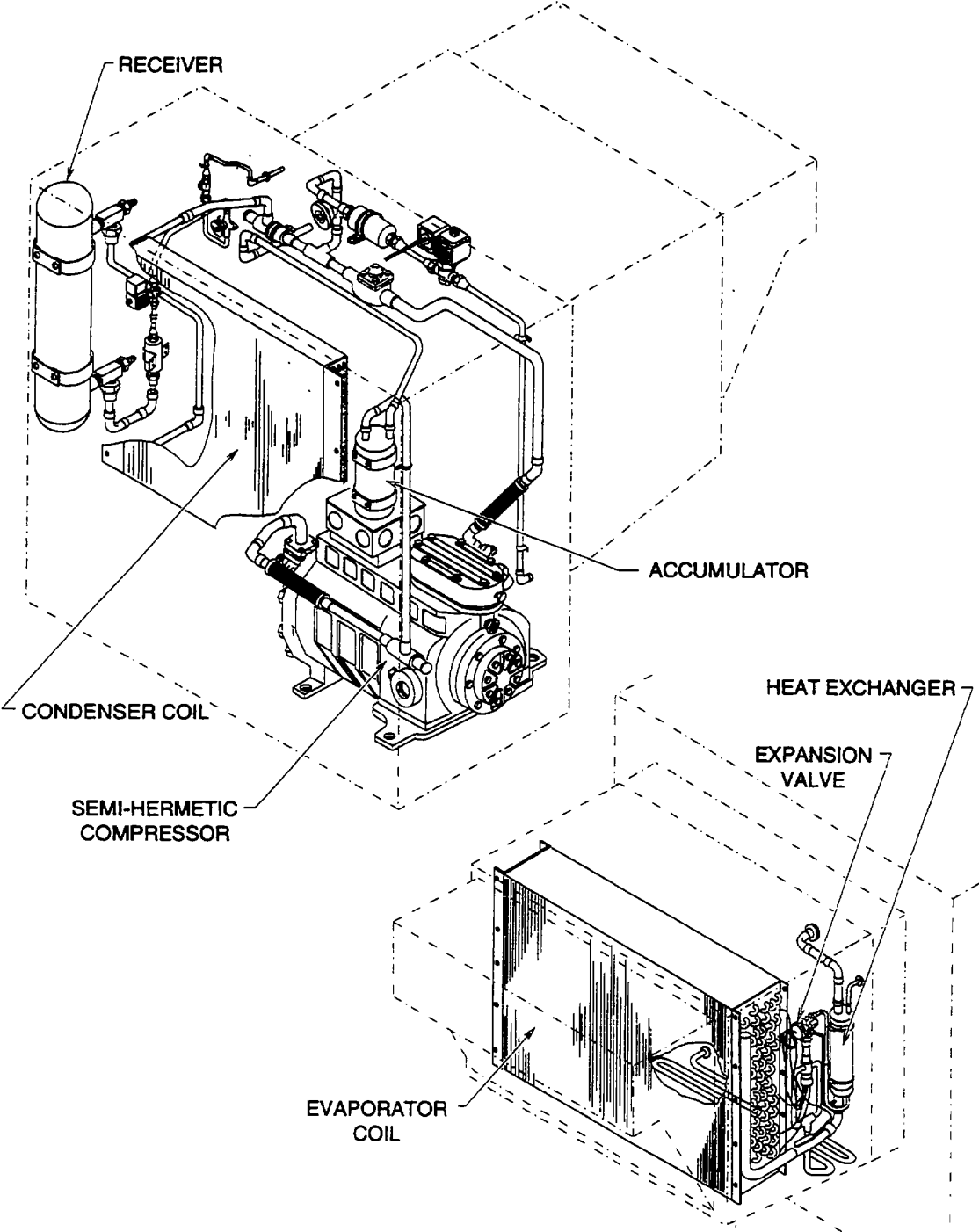
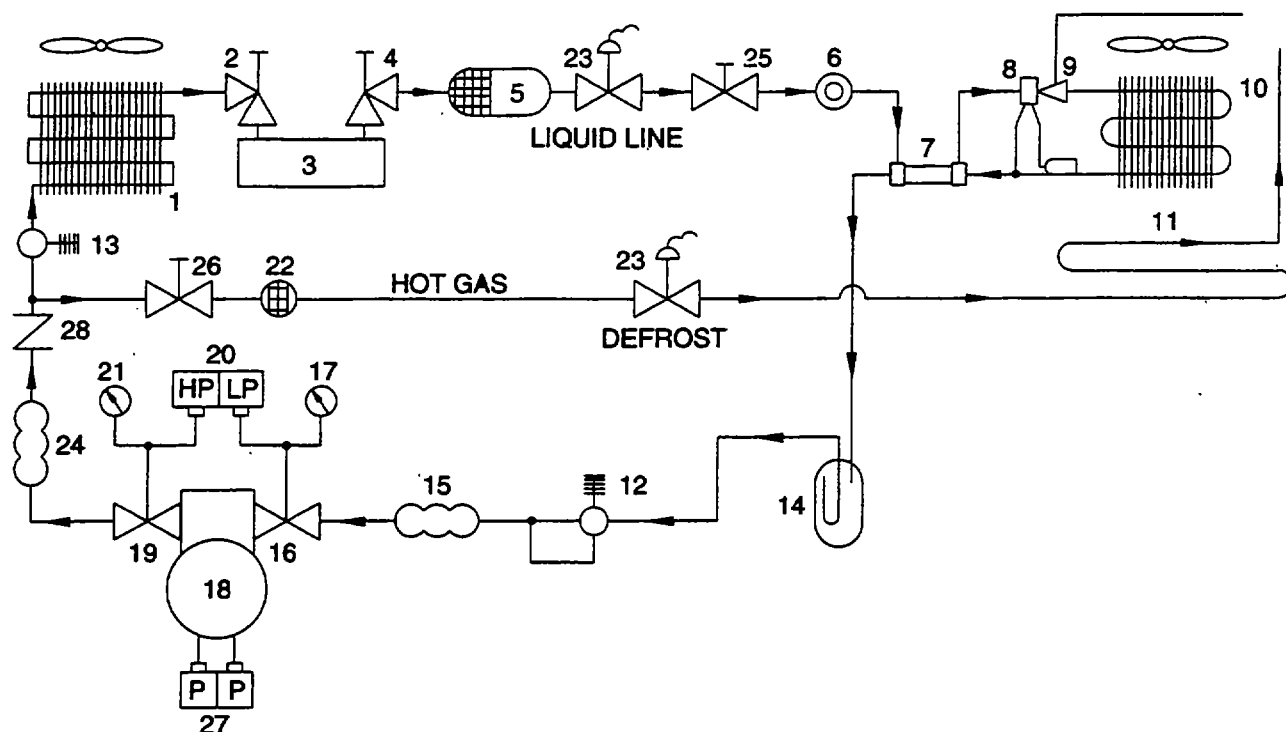

Figure 1-5. Refrigeration System



LEGEND			
ITEM	DESCRIPTION	ITEM	DESCRIPTION
1	CONDENSER	15	VIBRATION ABSORBER
2	SHUT-OFF VALVE	16	SUCTION SERVICE VALVE
3	RECEIVER	17	COMPOUND GAUGE
4	SHUT-OFF VALVE	18	SEMI-HERMETIC COMPRESSOR
5	FILTER DRIER	19	DISCHARGE SERVICE VALVE
6	MOISTURE LIQUID INDICATOR	20	DUAL PRESSURE CUTOFF SWITCH
7	HEAT EXCHANGER	21	HEAD PRESSURE GAUGE
8	THERMOSTATIC EXPANSION VALVE	22	STRAINER
9	DISTRIBUTOR	23	SOLENOID VALVE
10	EVAPORATOR	24	VIBRATION ABSORBER
11	DEFROST COIL	25	SHUT-OFF VALVE
12	CRANKCASE PRESSURE REGULATOR	26	SHUT-OFF VALVE
13	DISCHARGE PRESSURE REGULATOR	27	DIFFERENTIAL OIL PRESSURE SWITCH
14	SUCTION ACCUMULATOR	28	CHECK VALVE

Figure 1-6. Refrigeration Schematic

1.15 AIR HANDLING SYSTEM.

1.15.1 Refrigerator Enclosure. To absorb heat and cool the refrigerator enclosure, air must be circulated through the evaporator section of the refrigeration unit. Refrigerator enclosure air is drawn in through the coil guard and evaporator coil by the evaporator fan. The air is discharged through the evaporator air outlet guard back into the refrigerator enclosure.

1.15.2 Outside Ambient. To release heat absorbed in the refrigerator enclosure to the outside ambient, air must be circulated through the condenser section of the refrigeration unit. Outside ambient air is drawn in through the condenser guard and condenser coil by the condenser fan. The air is discharged through the side condenser doors and front bottom panels back to the outside ambient.

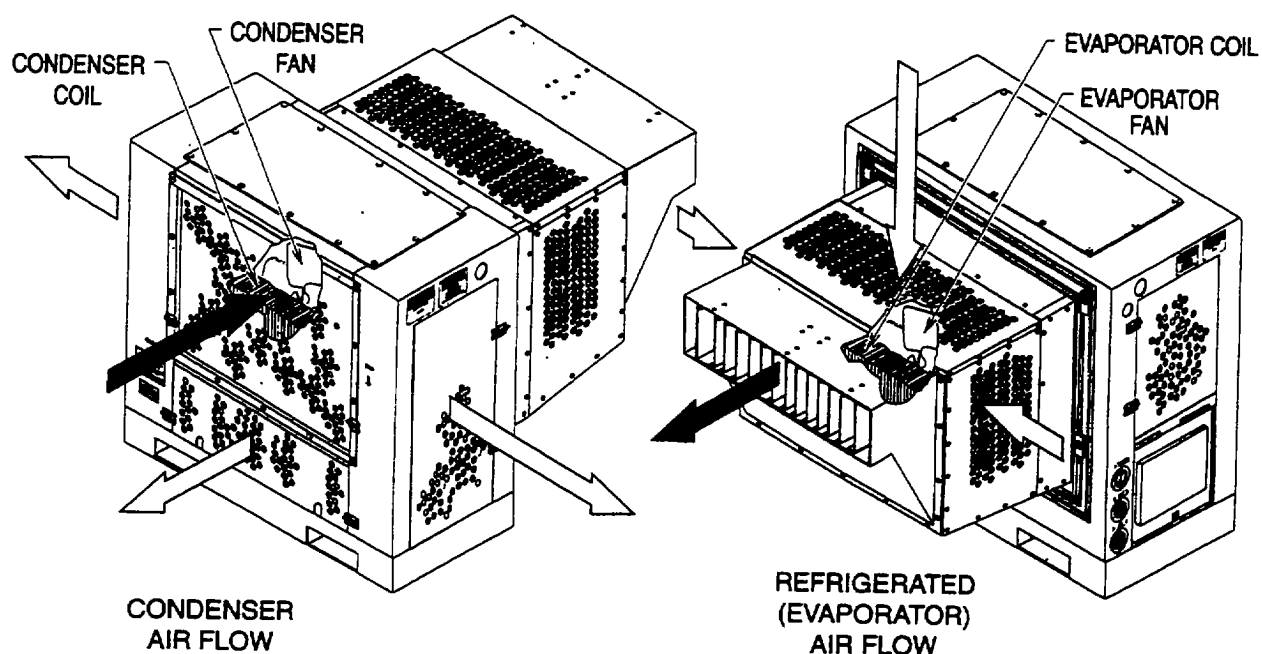

Figure 1-7. Air Flow

CHAPTER 2

OPERATING INSTRUCTIONS

Page

SECTION I	DESCRIPTION AND USE OF OPERATOR'S CONTROLS AND INDICATORS	2-1
	2-1 Operating Controls And Indicators	2-1
	2-2 Fault Controls and Indicators	2-4
SECTION II	PREVENTIVE MAINTENANCE CHECKS AND SERVICES	2-6
	2-3 General	2-6
SECTION III	OPERATION UNDER USUAL CONDITIONS	2-19
	2-4 Assembly and Preparation For Use.....	2-19
	2-5 Startup Procedures	2-19
	2-6 Operator Checks	2-19
	2-7 Shutdown Procedures.....	2-21
	2-8 Decals and Instruction Plates	2-21
SECTION IV	OPERATION UNDER UNUSUAL CONDITIONS	2-24
	2-9 Operation In Inclement Weather	2-24
	2-10 NBC Decontamination procedures.....	2-24

SECTION I DESCRIPTION AND USE OF OPERATOR'S CONTROLS AND INDICATORS

2.1 OPERATING CONTROLS AND INDICATORS.

The controls and indicators needed to operate and monitor the refrigeration unit are located on the control box assembly and inside the condenser frame.

- 1 Circuit Breaker (MAIN CIRCUIT BREAKER). Provides electrical circuit protection for the refrigeration unit. The circuit breaker handle should be in the ON position.
- 2 Remote Bulb Thermostat (TEMPERATURE CONTROL). Monitors and automatically controls the temperature inside the refrigerator enclosure. The remote bulb thermostat should be set to the desired refrigerator enclosure temperature.
- 3 Toggle Switch (START/RUN. OFF). Activates the refrigeration unit. The toggle switch should be in the START/RUN position.

2.1 OPERATING CONTROLS AND INDICATORS. - Continued

- 4 Thermometer (REFRIGERATION TEMPERATURE). Indicates the refrigerator enclosure temperature. The thermometer should indicate within 15° F (7° C) of the temperature set on the remote bulb thermostat.
- 5 Pressure Gauge (DISCHARGE PRESSURE). Indicates the pressure of the refrigerant gas leaving the compressor. The pressure gauge should generally indicate between 165 and 250 psi (1138 and 1725 kPa), at start up and/or operation in high temperatures, this range can go higher. The inner scale indicates the temperature of the refrigerant at any given pressure.
- 6 Compound Gauge (SUCTION PRESSURE). Indicates the pressure of the refrigerant gas entering the compressor. The compound gauge should generally indicate between 0 and 15 psi (0 and 103.5 kPa), at shutdown and/or operation in low temperatures, this range can go lower. The inner scale indicates the temperature of the refrigerant at any given pressure.
- 7 Sight Indicator (REFRIGERANT SIGHT GLASS). Provides a port through which the refrigerant may be observed as it passes through the liquid line of the refrigeration system. The center indicator changes color as it reacts to moisture in the refrigerant. The sight indicator port should be clear, indicating liquid refrigerant passing through it. An occasional flash of bubbles is normal as the refrigerant system automatically adjusts to changing conditions. The center indicator should be green or chartreuse in color.
- 8 Sight Glass (COMPRESSOR OIL SIGHT GLASS). Provides a port through which the oil level in the compressor may be observed. The sight glass port should show an oil level between $\frac{1}{4}$ and $\frac{1}{2}$ up the port. Bubbles in or on the oil surface is normal.
- 9 Hourmeter (HOURMETER). Indicates the total number of hours the compressor has operated.
- 10 Indicator (DEFROST IN PROGRESS). Indicates, by illuminating, when the refrigeration unit is operating in a defrost cycle.
- 11 Indicator (REFRIGERATION CYCLE ON). Indicates, by illuminating when the refrigeration cycle is on
- 12 Indicator (HEATING CYCLE ON). Indicates, by illuminating when the heating cycle is on.

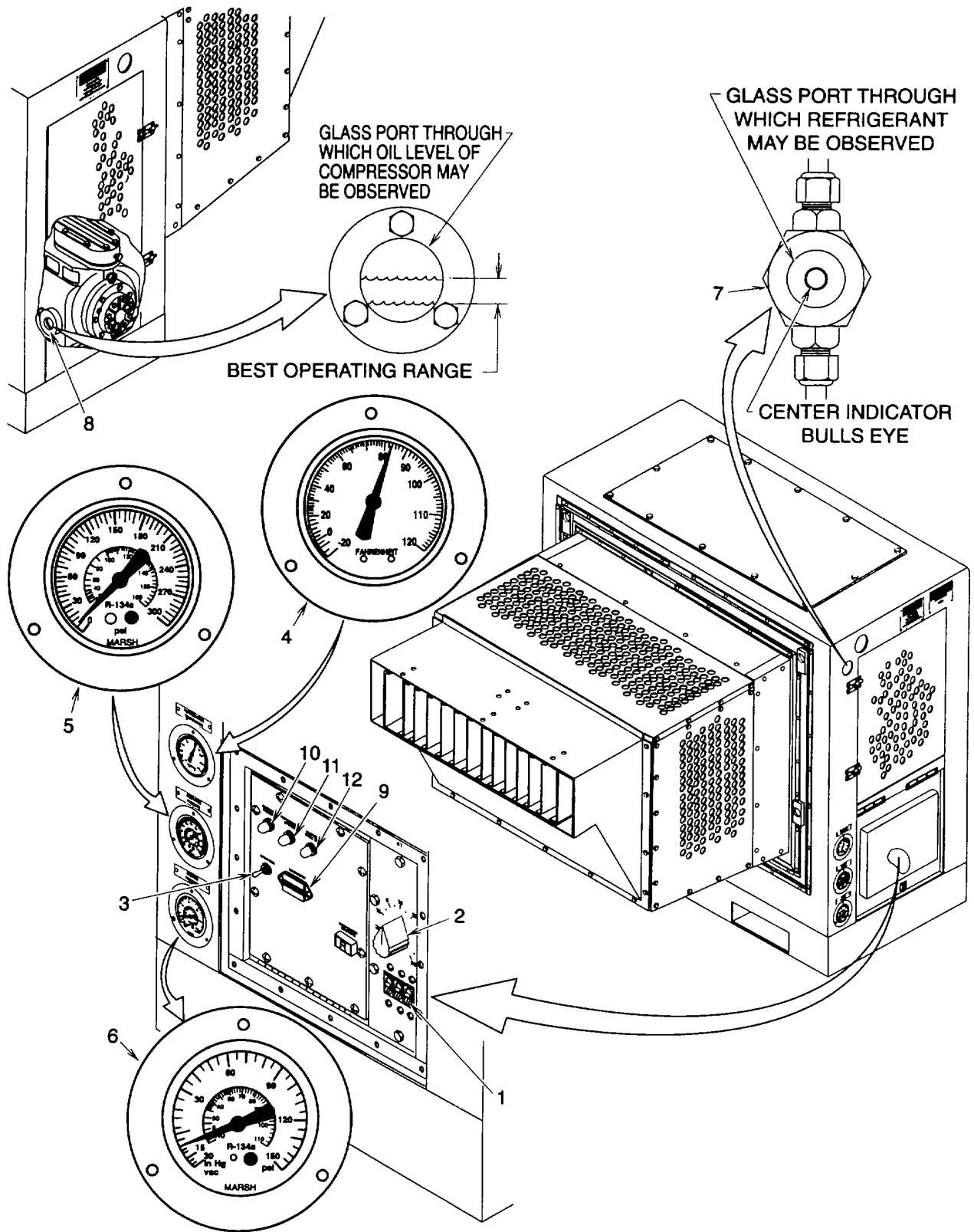

Figure 2-1. Operating Controls and Indicators

2.2 FAULT CONTROLS AND INDICATORS.

The controls and indicators needed to monitor and reset a fault condition on the refrigeration unit are located on the control box assembly and inside the condenser frame.

- 1 Thermometer (REFRIGERATOR TEMPERATURE). The thermometer will indicate more than 15° F (7° C) above or below the remote bulb thermostat setting if a fault occurs in the temperature control system.
- 2 Pressure Gauge (DISCHARGE PRESSURE). The pressure gauge will indicate more than 250 psi (1725 kPa) or less than 165 psi (1138.5 kPa) if a fault occurs in the refrigeration system. At start up, shut down, or operation in high temperatures, this range can go higher.
- 3 Compound Gauge (SUCTION PRESSURE). The compound gauge will indicate more than 15 psi (103.5 kPa) or less than 0 psi (0 kPa) if a fault occurs in the refrigeration system. At shut down or operation in low temperatures, this range can go lower.
- 4 Circuit Breaker (MAIN CIRCUIT BREAKER). The circuit breaker will be in a mid-way position if a fault has caused excessive load on the electrical system. To reset the circuit breaker, move the handle to the OFF position and then back to the ON position.
- 5 Reset Button (COMPRESSOR OVERLOAD). The reset button resets the motor starter if a fault has caused the compressor to overload. Push the reset button to reset the motor starter.
- 6 Dual Pressure Control Switch. The dual pressure control switch will open the electrical control circuit if a fault in the refrigeration system causes the pressure of the refrigerant gas leaving the compressor to exceed 300 psi (2070 kPa). The switch will automatically reset after a high pressure fault.
- 7 Differential Oil Pressure Switch. The differential oil pressure switch will open the electrical control circuit if a fault in the refrigeration system causes the compressor oil pressure to drop. Push the reset button to reset the differential oil pressure switch.
- 8 Sight Indicator (REFRIGERANT SIGHT GLASS). The sight indicator port will show continuous bubbles or foam in the refrigerant if there is a fault in the refrigeration system. The center indicator color will be yellow if moisture in the refrigerant exceeds safe operating limits.
- 9 Sight Glass (COMPRESSOR OIL SIGHT GLASS). The sight glass port will show the compressor oil level less than ¼ up the port or will show the oil foaming if there is a fault in the refrigeration system.

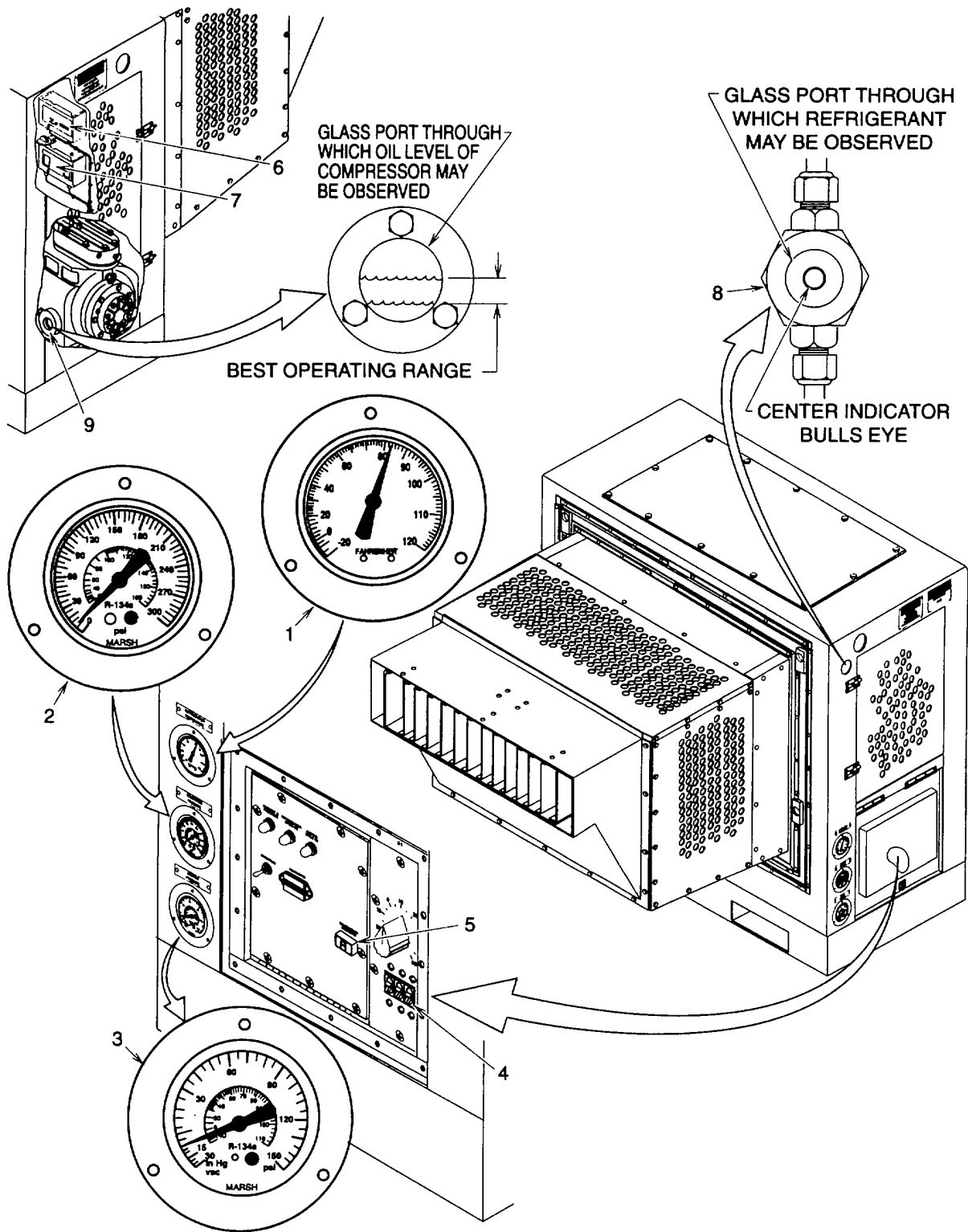

Figure 2-2. Fault Controls and Indicators

SECTION II PREVENTIVE MAINTENANCE CHECKS AND SERVICES

2.3 GENERAL.

Preventive Maintenance Checks and Services (PMCS) are essential to the efficient operation of the refrigeration unit and to prevent possible damage that might occur through neglect or failure to observe warning symptoms in a timely manner. Checks and services performed by operators are limited to those functions which can be done from the outside of the cabinet. The Preventive Maintenance Checks and Services Table 2-1 lists the inspections and care of the refrigeration unit required to keep it in good operating condition.

2.3.1 Warning and Cautions. Always observe the WARNINGS and CAUTIONS appearing in your PMCS Table. Warnings and cautions appear before applicable procedures. You must observe these WARNINGS and CAUTIONS to prevent serious injury to yourself and others or prevent your equipment from being damaged.

2.3.2 Explanation of Table Entries.

2.3.2.1 Item Number Column. Numbers in this column are for reference. When completing DA Form 2404 (Equipment Inspection and Maintenance Worksheet), include the item number for the check/service indicating a fault. Item numbers also appear in the order that you must do checks and services for the intervals listed.

2.3.2.2 Interval Column. This column tells you when you must do the procedure in the procedure column. BEFORE procedures must be done before you operate or use the equipment for its intended mission. DURING procedures must be done during the time you are operating or using the equipment for its intended mission. AFTER procedures must be done immediately after you have operated or used the equipment. When a check and service procedure is required for both WEEKLY and BEFORE intervals, it is not necessary to do the procedure twice if the equipment is operating during the WEEKLY period.

2.3.2.3 Location, Check/Service Column. This column provides the location and the item to be checked or serviced. The item location is underlined.

2.3.2.4 Procedure Column. This column gives the procedure you must do to check or service the item listed in the Check/Service column to know if the equipment is ready or available for its intended mission or for operation. You must do the procedure at the time stated in the interval column.

2.3.2.5 Not Fully Mission Capable IF: Column. Information in this column tells you what faults will keep your equipment from being capable of performing its primary mission. If you made a check and service procedure that shows faults listed in this column, do not operate the equipment. Follow standard operating procedures for maintaining the equipment or reporting equipment failure.

2.3.3 Other Table Entries. Be sure to observe all special information and notes that appear in your table.

2.3.4 Refrigerant Leaks. Oil is carried with the refrigerant as it flows through the refrigeration system. If a leak develops in the system, the oil will seep out and soak the copper tubing around the leak or drip and soak or puddle on the frame or other component below the leak. If any oil or seepage is found, a refrigerant leak would be suspected.

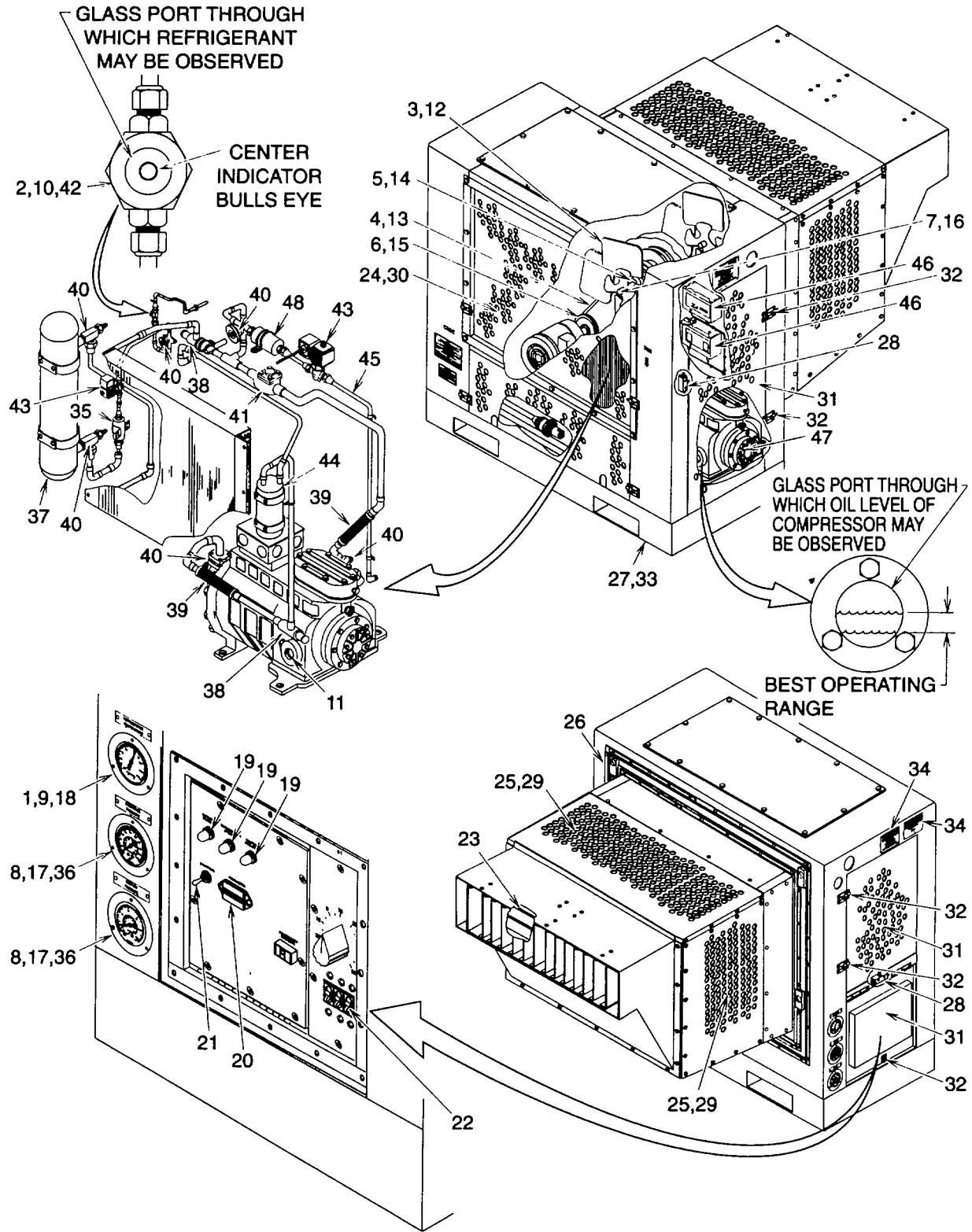

Figure 2-3. Operator's PMCS Routing Diagram

Table 2-1. Operator Preventive Maintenance Checks and Services

NOTE

If the equipment must be kept in continuous operation, do only the procedures that can be done without disturbing operation. Make complete checks and services when the equipment is shutdown.

Item No.	Interval	Location	Procedure	Not Fully Mission Capable If:
		Item to Check/Service		
1	Before	Refrigeration Unit Exterior	Thermometer should indicate refrigerator enclosure temperature. If it does not, notify unit maintenance to replace it.	Thermometer does not indicate refrigerator enclosure temperature.
		Thermometer		
2	Before	Refrigeration Unit Interior	<p style="text-align: center;"><u>WARNING</u> High voltage and exposed rotating parts are contained in the refrigeration unit. Personal injury can result if power is connected with doors open.</p>	Sight indicator port is cracked or center indicator color is yellow.
		Sight Indicator		
3	Before	Fan (Condenser)	Inspect condenser fan for cracks and tears. Inspect for loose connection to fan drive shaft. If damaged or loose, notify unit maintenance to tighten or replace it as necessary.	Fan is cracked, torn, or loose.
4	Before	V-Belt	Inspect the V-belt for frayed edges, cracks, glazing, or hard brittle condition. Inspect for excessive looseness or slippage. If damaged or loose, notify unit maintenance to tighten or replace it as necessary	V-belt is frayed, cracked, glazed, or hard and brittle. V-belt is excessively loose or slipping.
5	Before	Flange Bearings	Inspect flange bearings for loose or missing mounting hardware and looseness of fan drive shaft in bearing. If loose, notify unit maintenance to tighten or replace it as necessary.	Flange bearing mounts are loose or fan drive shaft is loose in bearing.

Table 2-1. Operator Preventive Maintenance Checks and Services - Continued

Item No.	Interval	Location	Procedure	Not Fully Mission Capable If:
		Item to Check/Service		
6	Before	Pulleys	Inspect pulleys for cracks, chips, or warpage. Inspect for secure mounting to shaft. If damaged or loose, notify unit maintenance to tighten or replace it as necessary.	Pulleys are cracked, chipped, warped, or loose on shaft.
7	Before	Fan Drive Shaft <u>Refrigeration Unit Exterior</u>	Inspect fan drive shaft for cracks, chips, or warpage. If damaged, notify unit maintenance to replace it necessary. NOTE <ul style="list-style-type: none"> • The gauges must not be inspected when the DEFROST IN PROGRESS or HEATING CYCLE ON indicators are on. • Pressures given are the acceptable operating range. 	Fan drive shaft is cracked, chipped, or warped.
8	During	Pressure Gauges	Inspect the (high) pressure gauge for reading between 165 and 250 psi (1138.5 and 1725 kPa) and the (low) pressure gauge for reading between 0 and 15 psi (0 and 103.5 kPa). If either gauge is out of acceptable operating range on a continuous basis, note the readings and shut down the refrigeration unit. Notify unit maintenance of the pressure readings. NOTE The thermometer must not be inspected when the DEFROST IN PROGRESS indicator is on.	Gauge reading above or below acceptable operating range.
9	During	Thermometer	Thermometer should indicate within 15° F (7° C) of TEMPERATURE CONTROL setting. If out of this range, shut down refrigeration unit and notify unit maintenance.	Thermometer indicates more than 15° F (7° C) above or below TEMPERATURE CONTROL setting.

Table 2-1. Operator Preventive Maintenance Checks and Services - Continued

Item No.	Interval	Location	Procedure	Not Fully Mission Capable If:
		Item to Check/Service		
10	During	Sight Indicator	<p style="text-align: center;">NOTE</p> <ul style="list-style-type: none"> • The sight indicator must not be inspected when the DEFROST IN PROGRESS or HEATING CYCLE ON indicators are on. • The sight indicator can be viewed looking through the left side condenser door. <p>Inspect sight indicator port for constant bubbles or foaming and note center indicator color. If constant bubbles or yellow indicator are seen, shut down refrigeration unit and notify direct support maintenance to leak check and evacuate refrigeration system as necessary.</p>	Sight indicator port shows constant bubbles or foam. Center indicator color is yellow.
11	During	Compressor (Oil Level Sight Glass)	<p style="text-align: center;">NOTE</p> <ul style="list-style-type: none"> • The sight glass must not be inspected when the DEFROST IN PROGRESS or HEATING CYCLE ON indicators are on. • The sight glass can be viewed looking through the front bottom panel. • Safe operating level is between ¼ and ½ way up the sight glass. <p>Inspect the sight glass port for low or high oil level and foaming. If oil level is out of safe operating range or foaming, shut down refrigeration unit and notify direct support maintenance to leak check and add oil to or remove oil from compressor as necessary.</p>	Sight glass port oil level above or below safe operating range or foaming.

Table 2-1. Operator Preventive Maintenance Checks and Services - Continued

Item No.	Interval	Location	Procedure	Not Fully Mission Capable If:
		Item to Check/Service		
		<u>Refrigeration Unit Interior</u>		
			<u>WARNING</u> High voltage and exposed rotating parts are contained in the refrigeration unit. Personal injury can result if power is connected with doors open.	
12	After	Fan (Condenser)	Inspect condenser fan for cracks and tears. Inspect for loose connection to fan drive shaft. If damaged or loose, notify unit maintenance to tighten or replace it as necessary.	Fan is cracked, torn, or loose.
13	After	V-Belt	Inspect the V-belt for frayed edges, cracks, glazing, or hard brittle condition. Inspect for excessive looseness or slippage. If damaged or loose, notify unit maintenance to tighten or replace it as necessary.	V-belt is frayed, cracked, glazed, or hard and brittle. V-belt is excessively loose or slipping.
14	After	Flange Bearings	Inspect flange bearings for loose or missing mounting hardware and looseness of fan drive shaft in bearing. If loose, notify unit maintenance to tighten or replace it as necessary.	Flange bearing mounts are loose or fan drive shaft is loose in bearing.
15	After	Pulleys	Inspect pulleys for cracks, chips, or warpage. Inspect for secure mounting to shaft. If damaged or loose, notify unit maintenance to tighten or replace it as necessary.	Pulleys are cracked, chipped, warped, or loose on shaft.
16	After	Fan Drive Shaft	Inspect fan drive shaft for cracks, chips, or warpage. If damaged, notify unit maintenance to replace it necessary.	Fan drive shaft is cracked, chipped, or warped.
		<u>Refrigeration Unit Exterior</u>		
17	Weekly	Pressure Gauges	Inspect the pressure gauges for cracked or missing lens and loose or missing mounting hardware. If damaged or loose, notify direct support maintenance to tighten or replace it as necessary.	

Table 2-1. Operator Preventive Maintenance Checks and Services - Continued

Item No.	Interval	Location	Procedure	Not Fully Mission Capable If:
		Item to Check/Service		
18	Weekly	Thermometer	Inspect the thermometer for cracked or missing lens and loose or missing mounting hardware. If damaged or loose, notify unit maintenance to tighten or replace it as necessary.	
19	Weekly	Indicators	Inspect the indicators for cracked or missing cap and loose base. Tighten cap if loose. If damaged or base is loose, notify unit maintenance to test, tighten base, or replace as necessary.	
20	Weekly	Hourmeter	Inspect the hourmeter for cracked or missing lens and loose or missing mounting hardware. If damaged or loose, notify unit maintenance to test, tighten, or replace it as necessary.	
			NOTE	
			Operating the toggle switch can cause the refrigeration unit to start or shut down.	
21	Weekly	Toggle Switch	Inspect the toggle switch for damaged handle and loose or missing mounting hardware. Inspect for smooth operation to START/RUN and OFF. If damaged, loose, or operation is stiff or binding, notify unit maintenance to test, tighten, or replace it as necessary.	Toggle switch will not stay in START/RUN position.
			NOTE	
			Operating the circuit breaker can cause the refrigeration unit to start or shut down.	
22	Weekly	Circuit Breaker	Inspect the circuit breaker for cracked or damaged handle and loose or missing mounting hardware. Inspect for smooth operation to ON and OFF. If damaged, loose, or operation is stiff or binding, notify unit maintenance to test, tighten, or replace it as necessary.	Circuit breaker will not stay in ON position or handle is damaged.

Table 2-1. Operator Preventive Maintenance Checks and Services - Continued

Item No.	Interval	Location	Procedure	Not Fully Mission Capable If:
		Item to Check/Service		
23	Weekly	Electric Heater	<p>a. Inspect the electric heaters for cracked or swollen sheath and loose or missing attaching hardware. If damaged or loose, notify unit maintenance to tighten or replace it as necessary.</p> <p>b. Inspect the electric heaters for frayed or broken wire leads. If damaged, notify unit maintenance to repair or replace it as necessary.</p>	The heater is damaged. Wire lead frayed or broken.
24	Weekly	Guard	Inspect the guard for any debris or foreign material obstructing the openings. Remove any debris or foreign material from the guard openings. If debris cannot be removed, notify unit maintenance to remove it.	Debris or foreign material obstructs the guard openings.
25	Weekly	Panels (Evaporator)	Inspect the panels for any debris or foreign material obstructing the openings. Remove any debris or foreign material from the panel openings. If debris cannot be removed, notify unit maintenance to remove it.	Debris or foreign material obstructs the panel openings.
26	Weekly	Gasket	Inspect for loose or missing gasket and for splits or tears. If damaged or loose, notify unit maintenance to tighten or replace it as necessary.	
27	Weekly	Condenser Enclosure	<p>a. Inspect the condenser enclosure for cracks and loose or missing hardware. If cracked, notify direct support maintenance for repair. If hardware is loose or missing, notify unit maintenance to tighten or replace it as necessary.</p> <p>b. Inspect the enclosure for any chipped or missing paint and evidence of corrosion. If paint is damaged or enclosure shows evidence of corrosion, notify direct support maintenance to paint it.</p>	Debris or foreign material obstructing the condensate drain opening.

Table 2-1. Operator Preventive Maintenance Checks and Services - Continued

Item No.	Interval	Location	Procedure	Not Fully Mission Capable If:
		Item to Check/Service		
27-Cont		Refrigeration Unit Interior	<p>c. Inspect the evaporator assembly condensate drain plastic tubing for any debris or foreign material obstructing it. Remove any debris or foreign material from the condensate drain tubing. If tubing cannot be cleaned, notify unit maintenance to clean it.</p> <p style="text-align: center;"><u>WARNING</u> High voltage and exposed rotating parts are contained in the refrigeration unit. Personal injury can result if power is connected.</p>	
28	Weekly	Push (Door) Switches	<p>a. Inspect the push switches for cracked case and loose or missing attaching hardware. If damaged or loose, notify unit maintenance to tighten or replace it as necessary.</p> <p>b. Inspect the push switches for smooth operation. If binding, notify unit maintenance to test and replace it as necessary.</p> <p>c. Inspect the push switches for frayed or broken wire leads. If damaged, notify unit maintenance to repair or replace it as necessary.</p>	The push switches stick. Wire lead frayed or broken.
29	Monthly	Refrigeration Unit Exterior Panels (Evaporator)	<p>a. Inspect the panels for any cracks, tears, and loose or missing hardware. If cracked, notify direct support maintenance for repair. If hardware is loose or missing, notify unit maintenance to tighten or replace it as necessary.</p>	

Table 2-1. Operator Preventive Maintenance Checks and Services - Continued

Item No.	Interval	Location	Procedure	Not Fully Mission Capable If:
		Item to Check/Service		
29 - Cont			<ul style="list-style-type: none"> b. Inspect for any chipped or missing paint and evidence of corrosion. If paint is damaged or panel shows evidence of corrosion, notify direct support maintenance to paint it. 	
30	Monthly	Guard	<ul style="list-style-type: none"> a. Inspect the guard for any cracks, tears, and loose or missing hardware. If cracked, notify direct support maintenance for repair. If hardware is loose or missing, notify unit maintenance to tighten or replace as necessary. b. Inspect for chipped or missing paint and evidence of corrosion. If paint is damaged or guard shows evidence of corrosion, notify direct support maintenance to paint it. 	
31	Monthly	Doors/Cover	<ul style="list-style-type: none"> a. Inspect the side doors and control box cover for any cracks, tears, and loose or missing hardware. If cracked, notify direct support maintenance for repair. If hardware is loose or missing, notify unit maintenance to tighten or replace as necessary. b. Inspect the doors and cover for any chipped or missing paint and evidence of corrosion. If paint is damaged or door/cover shows evidence of corrosion, notify direct support maintenance to paint it. c. Inspect the hinges for smooth operation and loose or missing attaching hardware. If hinges bind, notify unit maintenance to lubricate them. If attaching hardware is loose or missing, notify direct support maintenance to replace it. 	The side doors do not stay closed.

Table 2-1. Operator Preventive Maintenance Checks and Services - Continued

Item No.	Interval	Location	Procedure	Not Fully Mission Capable If:
		Item to Check/Service		
32	Monthly	Barrel Bolts	Inspect the barrel bolts for smooth operation and loose or missing attaching hardware. If barrel bolts bind, notify unit maintenance to lubricate them. If attaching hardware is loose or missing, notify unit maintenance to tighten or replace it as necessary.	
33	Monthly	Condenser Enclosure	Inspect for secure mounting to the refrigerator enclosure. If loose, notify unit maintenance to secure it.	Condenser enclosure is loose on refrigerator enclosure.
34	Monthly	Plates	Inspect for any damaged, loose, or missing information plates and loose or missing attaching hardware. If information plates are damaged or loose, notify direct support maintenance to tighten or replace them as necessary.	
		Refrigeration Unit Interior	<p style="text-align: center;"><u>WARNING</u> High voltage and exposed rotating parts are contained in the refrigeration unit. Personal injury can result if power is connected.</p>	
35	Monthly	Dehydrator	Inspect the dehydrator for damage or evidence of refrigerant leak. If damaged or evidence of leaking found, notify direct support maintenance to replace it.	Dehydrator is damaged or evidence of leak is found.
36	Monthly	Pressure Gauges	Inspect the gauges for evidence of refrigerant leak. If damaged or evidence of leaking found, notify direct support maintenance to replace it.	Evidence of leak is found.
37	Monthly	Receiver	Inspect the receiver for damage and evidence of refrigerant leak. Inspect the isolation valves for evidence of refrigerant leak. If damaged or evidence of leaking found, notify direct support maintenance to replace it.	Receiver is damaged or evidence of leak is found.

Table 2-1. Operator Preventive Maintenance Checks and Services - Continued

Item No.	Interval	Location	Procedure	Not Fully Mission Capable If:
		Item to Check/Service		
38	Monthly	Pressure Regulator Valves	Inspect the pressure regulator valves for damage or evidence of refrigerant leak. If damaged or evidence of leaking found, notify direct support maintenance to replace it.	Pressure regulator valve damaged or evidence of leak is found.
39	Monthly	Metal Hose Assemblies	Inspect the metal hose assemblies for kinks or evidence of refrigerant leak. If damaged or evidence of leaking found, notify direct support maintenance to replace it.	Metal hose assembly kinked or evidence of leak is found.
40	Monthly	Valves	Inspect the valves for evidence of refrigerant leak. If evidence of leaking found, notify direct support maintenance to replace it.	Evidence of leak is found.
41	Monthly	Check Valve	Inspect the check valve for evidence of refrigerant leak. If evidence of leaking found, notify direct support maintenance to replace it.	Evidence of leak is found.
42	Monthly	Sight Indicator	Inspect the sight indicator for evidence of refrigerant leak. If evidence of leaking found, notify direct support maintenance to replace it.	Evidence of leak is found.
43	Monthly	Solenoid Valves/Coils	Inspect the solenoid valves for frayed or broken wire leads, loose coil, loose or missing cover, and evidence of refrigerant leak. If coil is loose or damaged or wire leads are frayed or broken, notify unit maintenance to repair or replace it as necessary. If evidence of leaking found, notify direct support maintenance to replace it.	Wire lead frayed or broken, coil loose, or evidence of leak is found.
44	Monthly	Accumulator	Inspect the accumulator for damage and evidence of refrigerant leak. If damaged or evidence of leaking found, notify direct support maintenance to replace it.	Accumulator is damaged or evidence of leak is found.
45	Monthly	Tubing and Fittings.	Inspect the tubing and fittings for kinks, restriction (crushed), or evidence of refrigerant leak. If damaged or evidence of leaking found, notify direct support maintenance to tighten, repair, or replace as necessary.	Tubing or fittings damaged, kinked, or evidence of leak is found.

Table 2-1. Operator Preventive Maintenance Checks and Services - Continued

Item No.	Interval	Location	Procedure	Not Fully Mission Capable If:
		Item to Check/Service		
46	Monthly	Pressure Switches	Inspect the pressure switches for frayed or broken wire leads and dented, loose, or missing cover. Inspect for evidence of refrigerant leak. If cover is loose or wire leads are frayed or broken, notify unit maintenance to repair or replace it as necessary. If damaged or evidence of leaking found, notify direct support maintenance to replace it.	Wire lead frayed or broken, cover missing, or evidence of leak is found.
47	Monthly	Compressor	Inspect the compressor for frayed or broken wire leads and loose or missing terminal cover. Inspect the sight glass for cracks. Inspect for evidence of refrigerant leak. Inspect shut off valves for evidence of refrigerant leak. If wire leads are frayed or broken, notify unit maintenance to repair or replace as necessary. If damaged or evidence of leaking found, notify direct support maintenance to repair or replace as necessary.	Wire lead frayed or broken, cover missing, sight glass cracked or evidence of leak is found.
48	Monthly	Strainer	Inspect the strainer for damage or evidence of refrigerant leak. If damaged or evidence of leaking found, notify direct support maintenance to replace it.	Strainer is damaged or evidence of leak is found.

SECTION III OPERATION UNDER USUAL CONDITIONS

2.4 ASSEMBLY AND PREPARATION FOR USE.

The refrigeration unit requires specialized unpacking, installation, and power connection procedures. Notify unit maintenance for installation.

2.5 STARTUP PROCEDURES.

(See fig. 2-4.)

CAUTION

Operating the refrigeration unit with the service valves improperly set will damage the equipment. Do not operate unless you are sure it has been properly set up for operation. If you are not sure that service valves are properly set, notify unit maintenance.

- a. Be sure the refrigeration unit is connected to an active source of 208/230 Vac, 3 phase, 50/60 Hz electric power.

NOTE

Push switches in the side condenser door frames will prevent the refrigeration unit from operating if the side doors are open.

- b. Be sure both side condenser doors (1) are closed and secured.
- c. Set the remote bulb thermostat (2) (TEMPERATURE CONTROL) to the desired refrigerator enclosure temperature.
- d. Place the circuit breaker (3) handle in the ON position.
- e. Place the toggle switch (4) (START/RUN, OFF) handle in the START/RUN position.

2.6 OPERATOR CHECKS.

(See fig. 2-4.)

- a. Check the thermometer (5) (REFRIGERATION TEMPERATURE) periodically to be sure it is within 15° F (7° C) of the temperature set on the remote bulb thermostat (TEMPERATURE CONTROL).
- b. Check the pressure gauge (6) (DISCHARGE PRESSURE) periodically to be sure it is between 165 and 250 psi (1138.5 and 1725 kPa).
- c. Check the compound gauge (7) (SUCTION PRESSURE) periodically to be sure it is between 0 and 15 psi (0 and 103.5 kPa).

2.6 OPERATOR CHECKS. - Continued

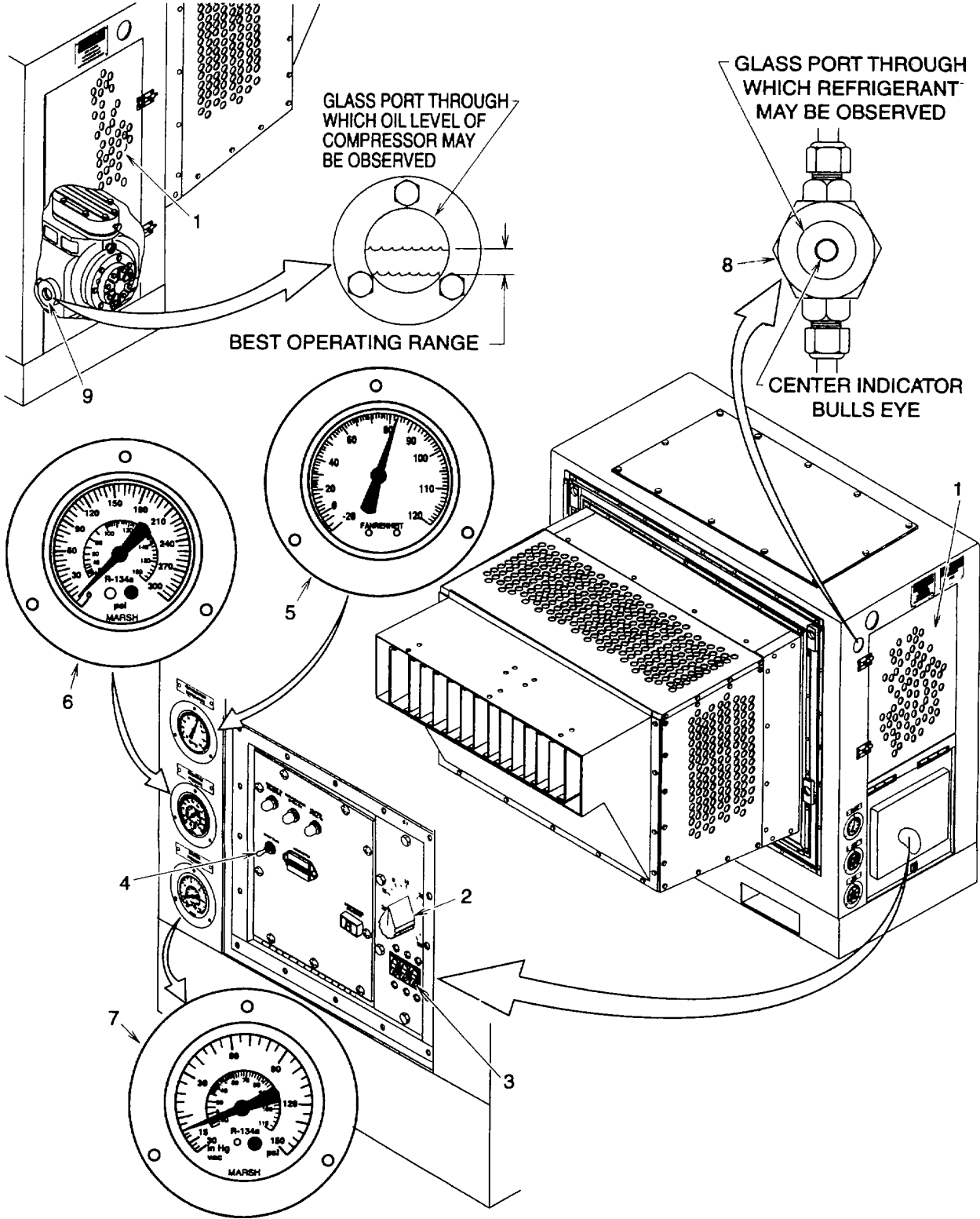

Figure 2-4. Operating Controls and Indicators

NOTE

An occasional flash of bubbles in the sight indicator (SIGHT GLASS) port is normal. The sight indicator can be viewed looking through the side condenser door.

- d. Check the sight indicator (8) (SIGHT GLASS) port to be sure it is clear. The center indicator should be green or chartreuse in color.

NOTE

An occasional flash of bubbles in the sight indicator (SIGHT GLASS) port is normal. The sight indicator can be viewed looking through the side condenser door.

- e. Check the compressor sight glass port (9) to be sure the oil is clear and the level is between $\frac{1}{4}$ and $\frac{1}{2}$ up the port.

2.7 SHUTDOWN PROCEDURES.

(See fig. 24.)

NOTE

If the refrigeration unit is to be left off for several days, it must be pumped down. Notify Unit Maintenance.

- a. Place the toggle switch (4) (START/RUN, OFF) handle in the OFF position.
- b. When the refrigeration unit stops running, place the circuit breaker (3) handle in the OFF position.
- c. Notify unit maintenance if the refrigeration unit is to be put into administrative storage for several days.

2.8 DECALS AND INSTRUCTION PLATES.

Decals and instruction plates are illustrated in the following figure.

2.8 DECALS AND INSTRUCTION PLATES. - Continued

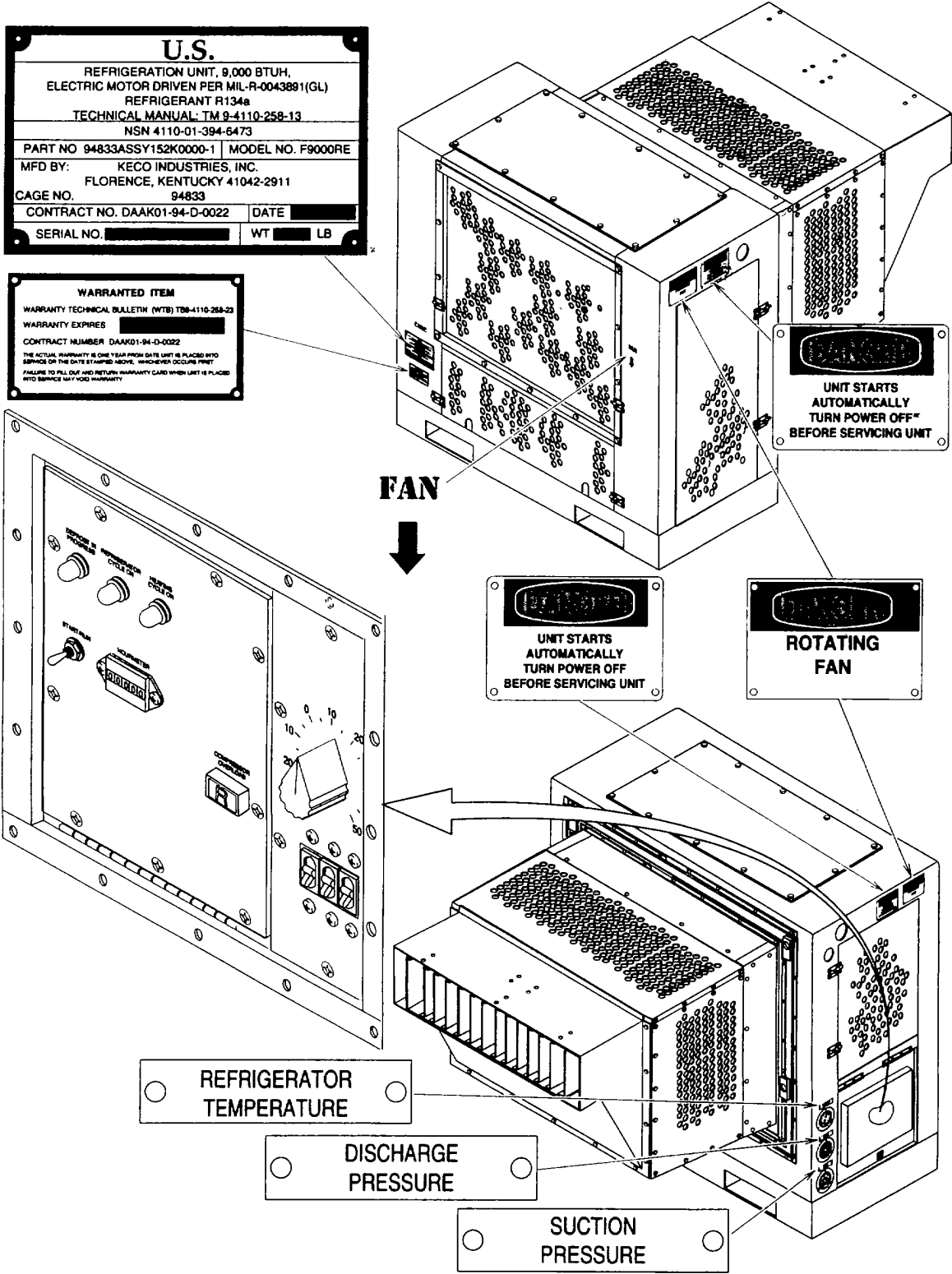
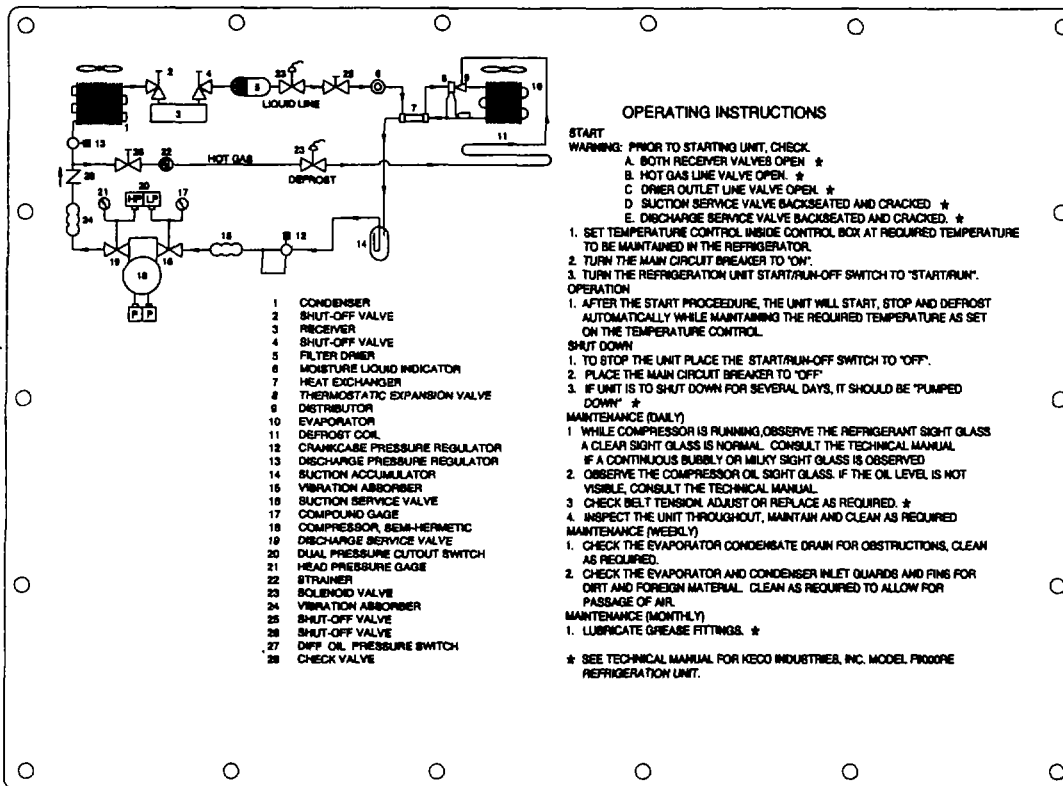

Figure 2-5. Decals and Instruction Plates (Sheet 1 of 2)

COVER
CONTROL
BOX
FRONT



COVER
CONTROL
BOX
REAR

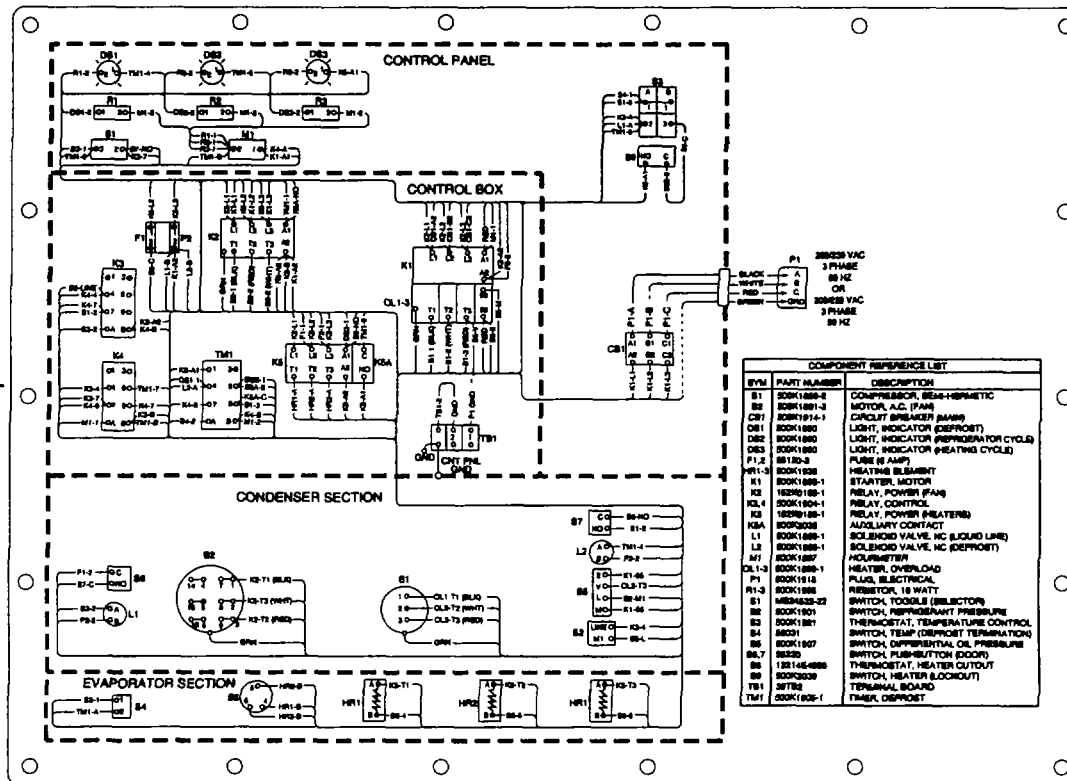

Figure 2-5. Decals and Instruction Plates (Sheet 2 of 2)

SECTION IV OPERATION UNDER UNUSUAL CONDITIONS

2.9 OPERATING IN INCLEMENT WEATHER.

The refrigeration unit is designed to operate under adverse conditions and does not require additional precautions or procedures.

2.10 NBC DECONTAMINATION PROCEDURES.

The following emergency procedures can be performed until field NBC decon facilities are available. If NBC attack is known or suspected, mask at once and continue mission. If outside, follow decon procedures below to avoid taking contamination into controlled area. Do not unmask until told to do so.

NOTE

Detailed decontamination procedures can be found in: FM 3-3, FM 3-4, and FM 3-5.

- a. Nuclear Decontamination. Brush fallout from skin, clothing and equipment with available brushes, rags, and tree branches. Wash skin and have radiation check made when tactical situation permits.
- b. Biological Decontamination. Remain masked and continue mission until told to unmask.
- c. Chemical Detection and Decontamination.

WARNING

Some decontamination sprays can cause personal injury and should not be used on personnel.

- (1) Contact your local chemical detachment or unit for proper use of decontamination equipment.
- (2) If exposure to liquid agent is known or suspected, clean exposed skin, clothing, personal gear, and equipment, in that order, using M258A1 kit. Use the buddy system. Wash exposed skin and thoroughly decontaminate when tactical situation permits.
- (3) Use M8 paper from the M256 Chemical Agent Detector Kit or M9 paper to determine if liquid agent is present on the equipment.
- (4) If the M8 or M9 paper indicates that liquid chemical agent is present on the equipment, use the NBC-M11 decon apparatus to decon equipment

CHAPTER 3

OPERATOR MAINTENANCE INSTRUCTIONS

		Page
SECTION I	LUBRICATION	3-1
	3-1 Lubrication.....	3-1
SECTION II	TROUBLESHOOTING PROCEDURES	3-1
	3-2 Troubleshooting.....	3-1
SECTION III	OPERATOR'S MAINTENANCE INSTRUCTIONS.....	3-3
	3-3 General	3-3
	3-4 Cleaning	3-3

SECTION I LUBRICATION

3.1 LUBRICATION.

Operator lubrication not required.

SECTION II TROUBLESHOOTING PROCEDURES

3.2 TROUBLESHOOTING.

The following procedures are listed in order of the most probable malfunctions. Each malfunction is followed by test or inspection procedures in logical order to isolate and identify the fault and actions required to correct it. This section cannot list all the possible malfunctions that may occur with the equipment. If a malfunction occurs that is not listed or actions listed do not correct a malfunction, notify your supervisor.

3.2 TROUBLESHOOTING. -Continued

MALFUNCTION INDEX

Troubleshooting
Procedure
Para

Refrigeration unit does not start.....3.2

REFRIGERATION UNIT DOES NOT START.

IS POWER SOURCE CONNECTED AND ACTIVE?

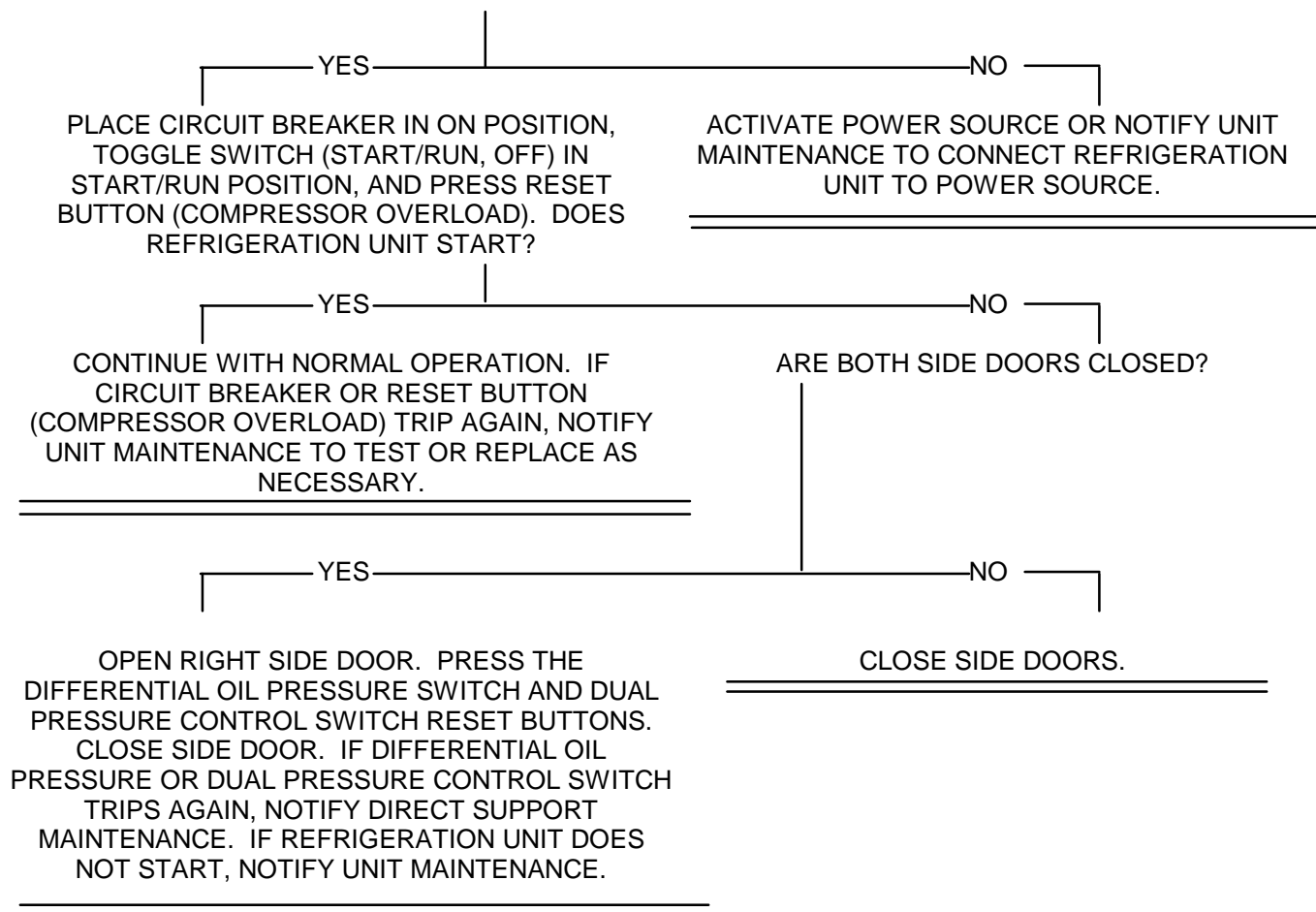

SECTION III OPERATOR'S MAINTENANCE PROCEDURES

INDEX

	Para
ENCLOSURE	
General.....	3.3
Cleaning	3.4

3.3 GENERAL.

With the exception of service and inspection procedures noted in the PMCS table 2-1, the following maintenance procedure is the only one authorized to the operator.

3.4 CLEANING.

This task covers:

- a. Cleaning
-

INITIAL SETUP

Equipment Conditions:

Reference

- Para 2.7 Refrigeration unit shut down.
- Doors open as necessary.

Materials/Parts:

Detergent

- 6, Appendix E

Rag

- 2, Appendix E
-

General Safety Instructions:

WARNING

High voltage and exposed rotating parts are contained in the refrigeration unit. Personal injury can result if power is connected.

Cleaning.

- (1) Mix a small quantity of detergent with clean water to make a wash solution.
- (2) Dampen a rag with wash solution and clean the equipment.
- (3) Dampen a rag with clean water and rinse the equipment. Rinse rag in clean water and continue until all detergent residue has been removed.
- (4) Wipe the equipment with a clean dry rag until thoroughly dry.

CHAPTER 4**UNIT MAINTENANCE INSTRUCTIONS****SECTION I LUBRICATION INSTRUCTIONS****4.1 LUBRICATION.**

Lubrication instructions are contained in Section III, unit level PMCS table 4-1.

**SECTION II REPAIR PARTS, TOOLS, SPECIAL TOOLS, TEST, MEASUREMENT,
AND DIAGNOSTIC EQUIPMENT (TMDE), AND SUPPORT EQUIPMENT****4.2 COMMON TOOLS AND EQUIPMENT.**

4.2.1 For authorized common tools and equipment, refer to the Modified Table of Organization and Equipment (MTOE), CTA 50-970, or CTA 8-100, as applicable to your unit.

4.2.2 The Shop Equipment (1), Automotive Vehicle (SC 4910-95-CL-A74) will be used for all maintenance tasks. Any additional tools required for an individual maintenance task will be identified in the setup information for that task.

4.3 SPECIAL TOOLS, TMDE, AND SUPPORT EQUIPMENT.

4.3.1 The Repair Parts and Special Tools List (RPSTL) (TM 9-4110-258-23P) as well as the Maintenance Allocation Chart (MAC) (appendix B) identify any tools and support equipment needed to maintain the refrigeration unit.

4.3.2 There are no special or fabricated tools required to maintain the refrigeration unit.

4.4 REPAIR PARTS.

4.4.1 Any mandatory replacement parts needed for the maintenance tasks are identified in the mandatory replacement parts list located in Appendix G.

4.4.2 Repair parts are listed and illustrated in the repair parts and special tools list (TM 9-4110-258-23P) covering unit maintenance for this equipment.

SECTION III SERVICE UPON RECEIPT**4.5 SITE AND SHELTER REQUIREMENTS.**

4.5.1 The refrigeration unit requires a source of 200-230 Vac, and 50/60 Hz.

4.5.2 The refrigerator enclosure must have an accessible wall area of a minimum of 46 inches high and 50 inches wide.

4.5.3 The refrigeration unit weighs 1,000 lbs.

4.6 SERVICE UPON RECEIPT OF MATERIAL.

4.6.1 Inspect the equipment for damage incurred during shipment. If the equipment has been damaged, report the damage on SF 364, Report of Discrepancy.

4.6.2 Check the equipment against the packing slip to see if the shipment is complete. Report all discrepancies in accordance with the instructions of DA Pam 738-750 as applicable.

4.7 INSTALLATION INSTRUCTIONS.

4.7.1 Tools and Equipment. Tools required -to install the refrigeration unit include a wrench for tightening-the mounting hardware, lifting sling(s) (with hooks), spreader-bar (if needed), and hoist or similar lifting device.

4.7.2 Refrigerator Enclosure Preparation. The refrigerator enclosure must have an opening 36.00 inches (91.4 cm) wide and 27.00 inches (68.6 cm) high and four 0.88 inch (2.24 cm) mounting holes (fig. 4-1). If an opening does not already exist in the enclosure, see the enclosure manual for information on making such an opening.

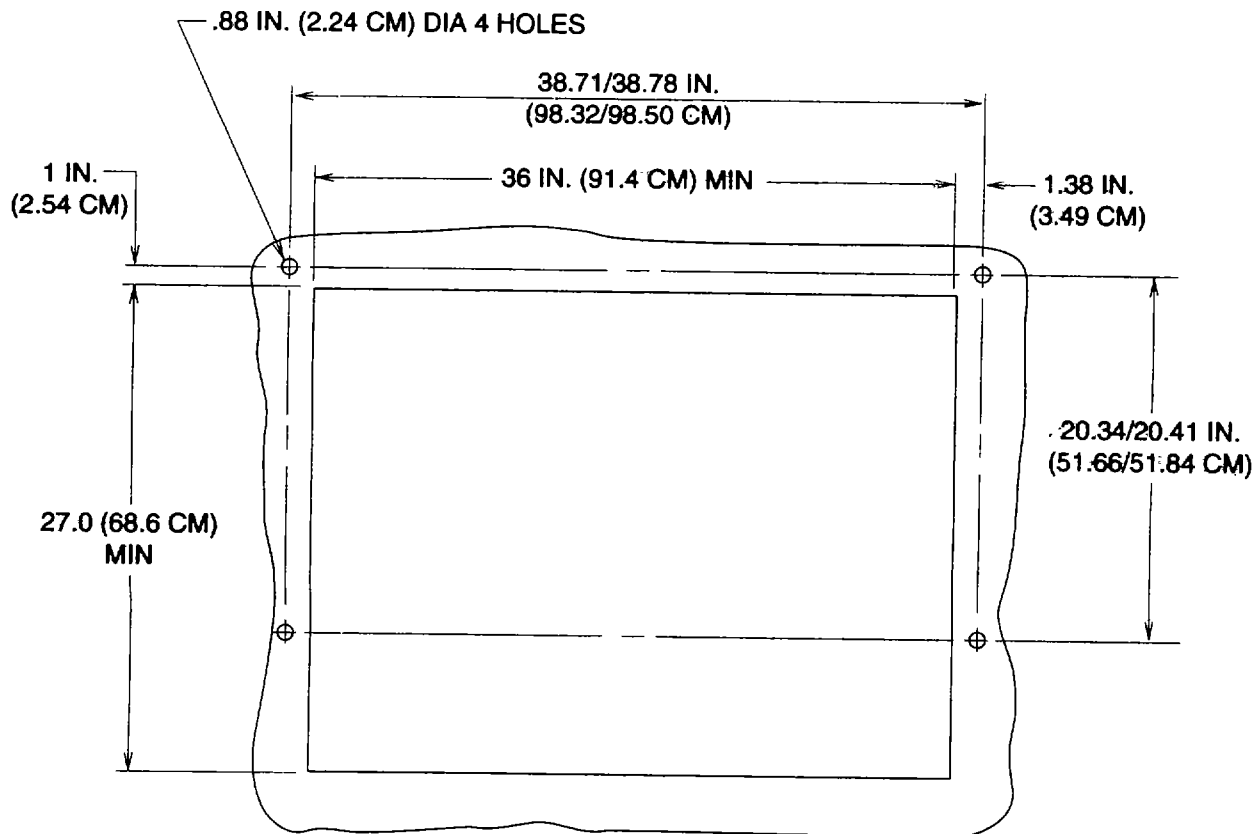

Figure 4-1. Wall Opening Dimensions

a. Installation.

NOTE

Mounting hardware is not supplied with the unit. See enclosure manual for information on appropriate hardware to use.

- (1) Attach the sling(s) to the reinforced lifting holes.

CAUTION

Failure to use a spreader bar or two point lifting device, such as a fork lift, can cause damage to the condenser frame when lifted.

- (2) If a single point lifting device is being used, install the spreader bar onto the sling(s) at approximate mid-way point.

WARNING

The refrigeration unit can swing and move when lifted. Personal injury can result if standing near unit when it is lifted.

- (3) Connect a hoist or similar lifting device to the sling(s) and lift the refrigeration unit.

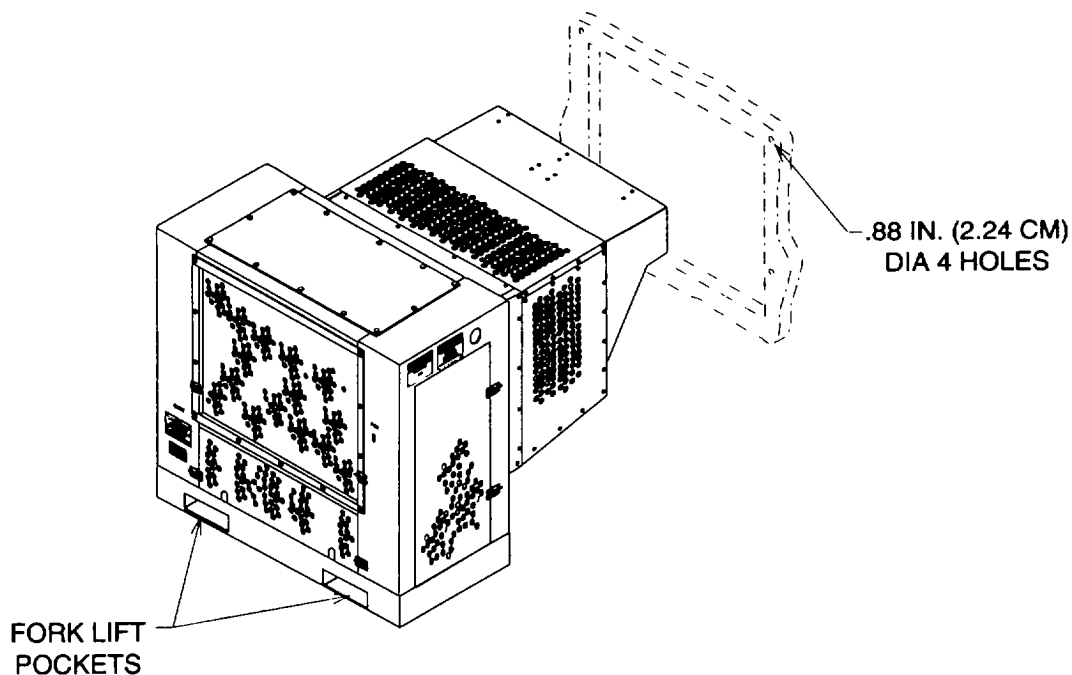

Figure 4-2. Installation

4.7.2 Refrigerator Enclosure Preparation. - Continued

- (4) Carefully position the refrigeration unit into the refrigerator enclosure opening.
- (5) Secure the refrigeration unit to the refrigerator enclosure using appropriate hardware.
- (6) Remove sling(s).

b. Power Connection.

- (1) Open front door and secure with barrel bolt provided on panel above.
- (2) Uncoil power cable from stowage area.
- (3) Position power cable through cutouts provided on front door being careful not to pinch cable when door is closed.
- (4) Close door and latch barrel bolts.

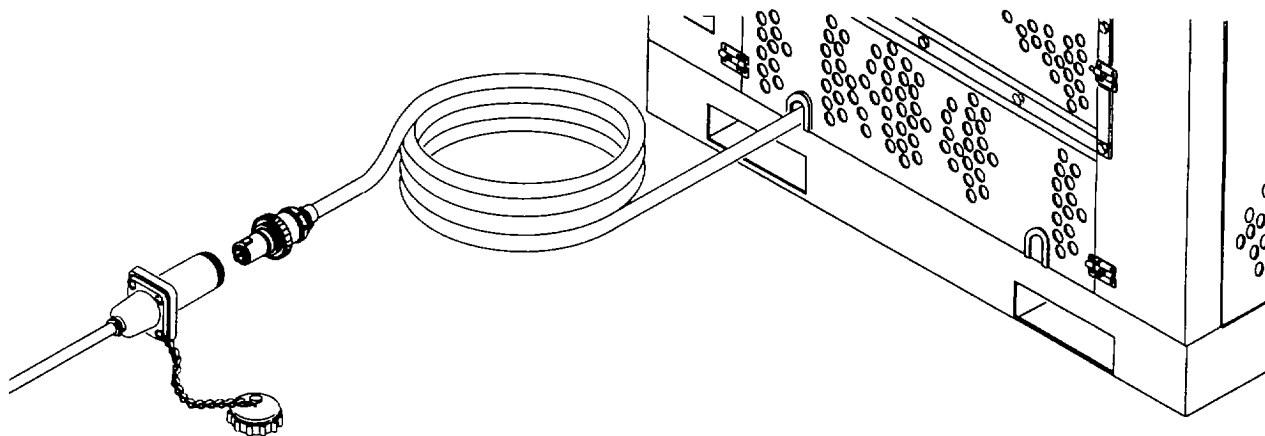

Figure 4-3. Input Power Cable

4.8 PRELIMINARY SERVICING OF EQUIPMENT.

- a. Open both side condenser doors.

CAUTION

Using excessive force when opening or closing valves can cause damage to the valve seats.

- b. Fully open both stop valves (1, fig. 4-4) and (2).

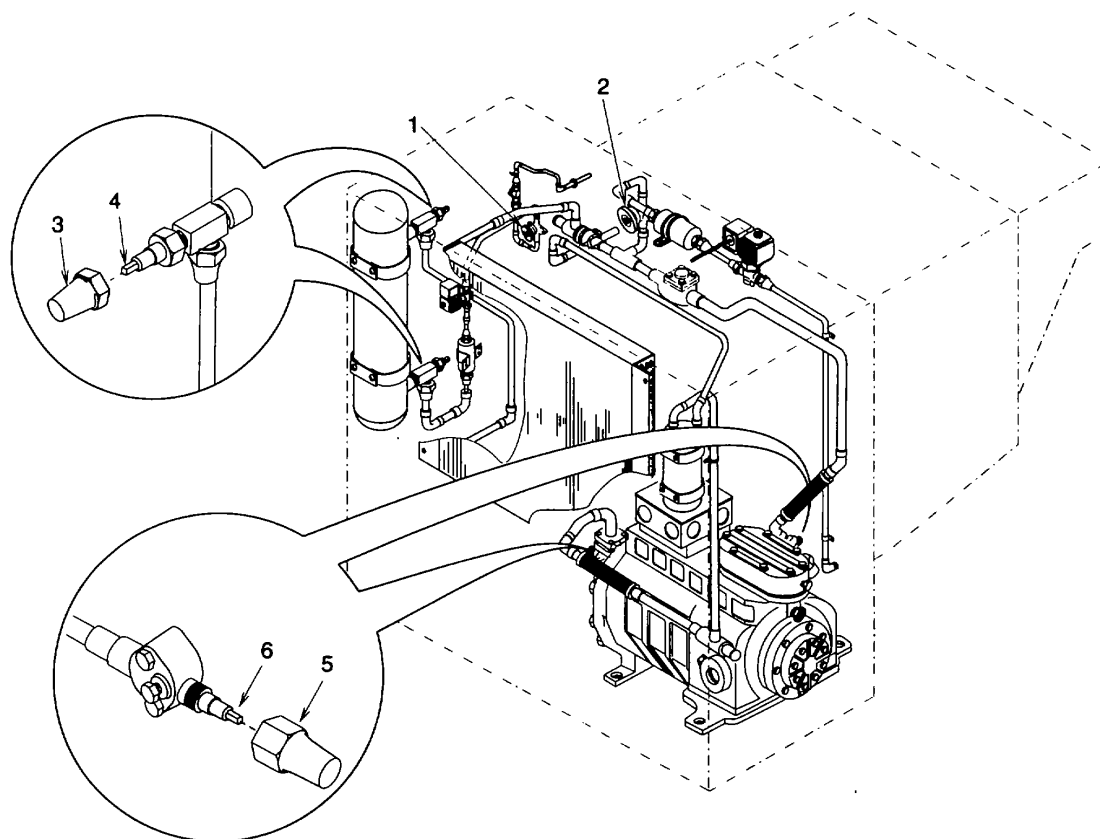

Figure 4-4. Refrigeration Valve Setting for Normal Operation

- c. Remove two caps (3) and fully open two isolation valves (4). Install two caps.

NOTE

The compressor shut off valves can be adjusted to three positions, fully closed to block the refrigerant tubes and isolate the compressor and service ports. Fully open to allow flow from piping to compressor but not the service port or cracked (one turn closed from fully open) to allow flow from piping to compressor and service port on valve

- d. Remove two caps (5) and fully open two shut off valves (6). Install two caps.
 e. Loosen four compressor mount locknuts (1, fig. 4-5) until proper operating space 1.5 in. (3.81 cm) is reached.

4.8 PRELIMINARY SERVICING OF EQUIPMENT. - Continued

Figure 4-5. Compressor Mount

- f. Close both side condenser doors.

4.9 PRELIMINARY ADJUSTMENT OF EQUIPMENT.

- a. Open control box cover and secure open with door holder clips.
b. Remove six screws (1, fig. 4-6). Open the control box cover (2).

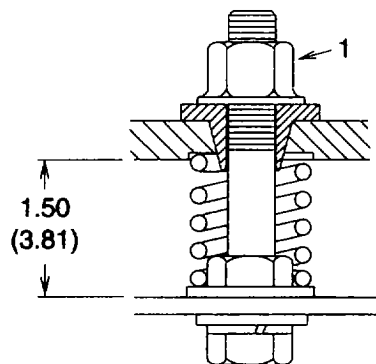
NOTE

- **The defrost timer controls are marked T1 and T2. Control T1 adjusts the length of time the refrigeration unit will operate continuously before initiating a defrost cycle. Control T2 adjust the maximum length of time the refrigeration unit will remain in the defrost cycle.**
 - **The time scales indicate an approximate percentage of time based on 24 hours. For example, to set the time for 6 hours, adjust the control to 25% (6 hours is 25% of 24 hours).**
 - **The time controls have a minimum setting of 14 minutes when set a 0%.**
- c. Adjust the defrost timer (3) control T1 to approximately 25% (6 hours) and control T2 to approximately 2% (30 minutes). This is the recommended factory setting, however, the controls can be set as desired to best suit the operating conditions.
- d. Close the control box cover (2). Install six screws (1).
- e. Close and secure the control box cover.
- f. Adjust dual pressure control switch (4) HIGH PRESSure CUTOUT to 305, low pressure CUT IN to 0, and low pressure CUTOUT to 15 IN. VAC.

RANGE ADJUSTING SCREW
SET CUT-IN POINT FIRST WITH THIS SCREW.
(CHANGES BOTH CUT-IN AND CUTOUT POINTS)

CUTOUT POINT SETTING KNOB
(CHANGES CUTOUT POINT ONLY)

HIGH PRESSURE CUTOUT
ADJUSTMENT SCREW
(DIFFERENTIAL IS FACTORY SET)

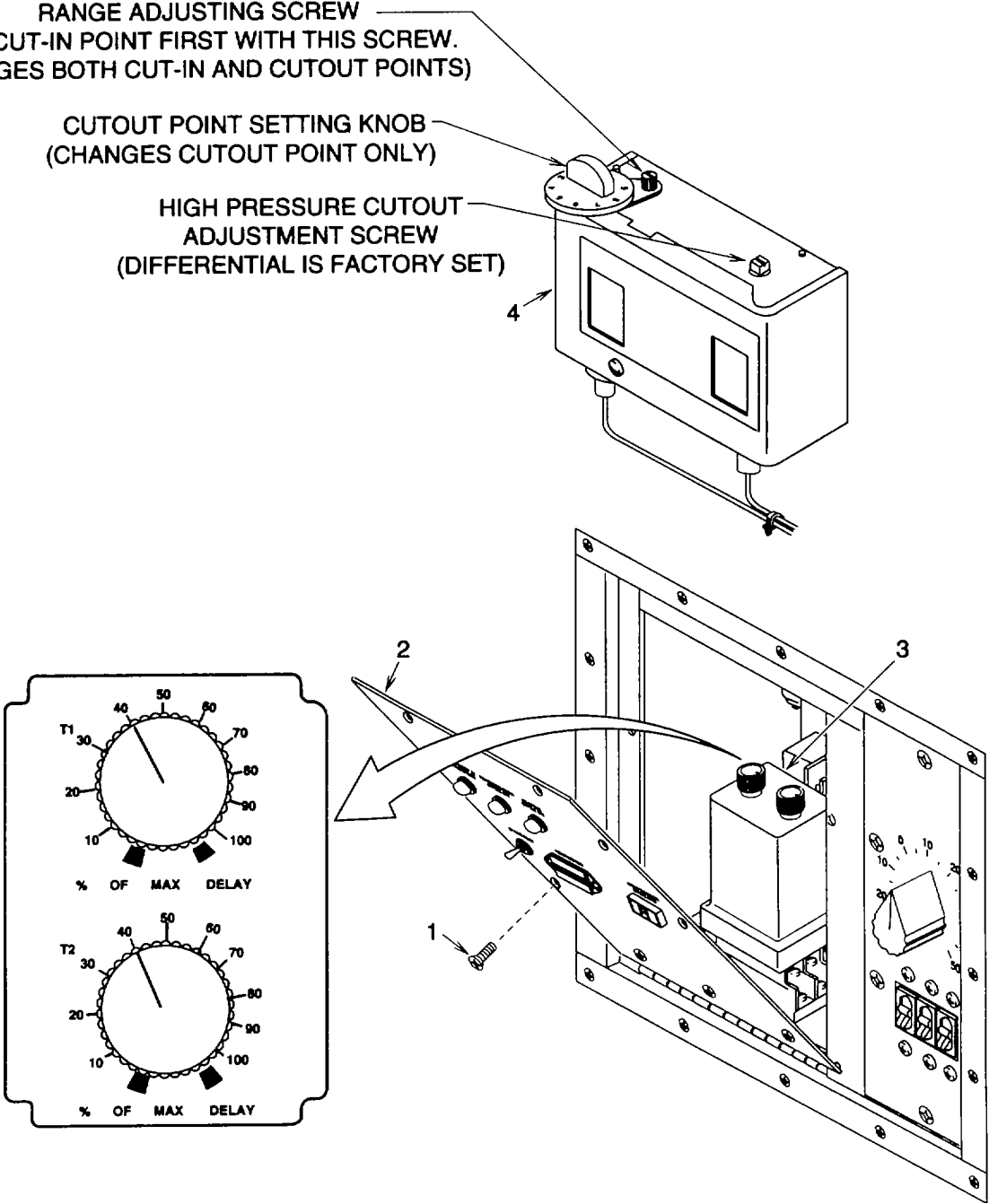

Figure 4-6. Preliminary Adjustment

SECTION IV UNIT PREVENTIVE MAINTENANCE CHECKS AND SERVICES (PMCS)

4.10 LUBRICATION.

The lubrication instructions and hardtime intervals contained in figure 4-7 are mandatory. This refrigeration unit is not enrolled in the Army Oil Analysis Program. HARDTIME INTERVALS APPLY.

4.11 GENERAL.

Preventive Maintenance Checks and Services (PMCS) are essential to the efficient operation of the refrigeration unit and to prevent possible damage that might occur through neglect or failure to observe warning symptoms in a timely manner. Intervals are determined by hours in operation expressed in applicable units of measure. The Preventive Maintenance Checks and Services Table 4-1 lists procedures done first or most frequently.

4.11.1 Warnings and Cautions. Always observe the warnings and cautions appearing in your PMCS Table. Warnings and cautions appear before applicable procedures. You must observe these warnings and cautions to prevent serious injury to yourself and others or prevent your equipment from being damaged.

4.11.2 Explanation of Table Entries.

4.11.2.1 Item Number Column. Numbers in this column are for reference. When completing DA Form 2404 (Equipment Inspection and Maintenance Worksheet), include the item number for the check/service indicating a fault. Item numbers also appear in the order that you must do checks and services for the intervals listed.

4.11.2.2 Interval Column. This column tells you when you must do the procedure in the procedure column. BEFORE procedures must be done before you operate or use the equipment for its intended mission. DURING procedures must be done during the time you are operating or using the equipment for its intended mission. AFTER procedures must be done immediately after you have operated or used the equipment. When a check and service procedure is required for both WEEKLY and BEFORE intervals, it is not necessary to do the procedure twice if the equipment is operating during the WEEKLY period.

4.11.2.3 Location, Check/Service Column. This column provides the location and the item to be checked or serviced. The item location is underlined.

4.11.2.4 Procedure Column. This column gives the procedure you must do to check or service the item listed in the Check/Service column to know if the equipment is ready or available for its intended mission or for operation. You must do the procedure at the time stated in the interval column.

4.11.2.5 Not fully Mission Capable If: Column. Information in this column tells you what faults will keep your equipment from being capable of performing its primary mission. If you made a check and service procedure that shows faults listed in this column, do not operate the equipment. Follow standard operating procedures for maintaining the equipment or reporting equipment failure.

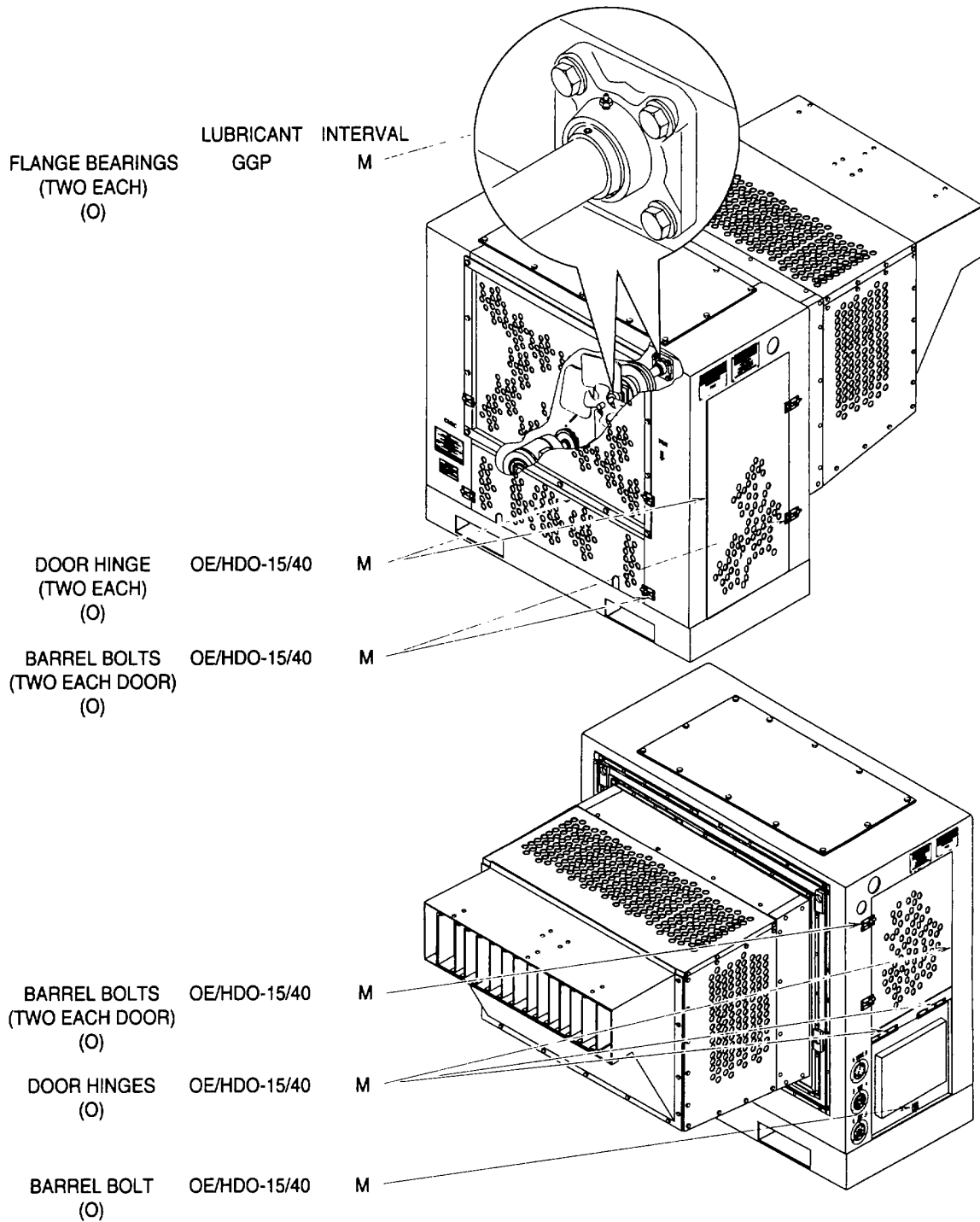

Figure 4-7. Lubrication

4.11.3 Special Information Paragraphs

4.11.3.1 Corrosion Prevention Control. If a corrosion problem is identified, it can be reported using Standard Form 368, Production Quality Deficiency Report. The form should be submitted to the address specified in DA Pam 738750. This will result in more definitive actions be taken to prevent future occurrences.

4.11.3.2 Leakage Definition for Unit PMCS. It is necessary for you to know how fluid leakage affects the status of your refrigeration unit. Oil is carried with the refrigerant as it flows through the refrigeration system. If a leak develops in the system, the oil will seep out and soak the copper tubing around the leak or drip and soak or puddle on the frame or other component below the leak. If any oil or seepage is found, a refrigerant leak would be suspected.

4.11.3.2.1 Class I is defined as seepage of fluid (as indicated by wetness or discoloration) but not great enough to form drops.

4.11.3.2.2 Class II is defined as leakage of fluid great enough to form drops but not enough to cause drops to drip from item being checked/inspected.

4.11.3.2.3 Class III is defined as leakage of fluid great enough to form drops that fall from item being checked/inspected.

INITIAL SETUP

Tools:

Fin Comb
2, Section III, Appendix B

General Safety Instructions:

WARNING

Materials/Parts:

Wiping Rag
3, Appendix E
Detergent
4, Appendix E
General Purpose Lubricating Oil
5, Appendix E
Multipurpose Grease
6, Appendix E

High voltage and exposed rotating parts are contained in the refrigeration unit. Personal injury can result if power is connected.

Table 4-1. Preventive Maintenance Checks and Services for Model F9000RE

NOTE

If the equipment must be kept in continuous operation, do only the procedures that can be done without disturbing operation. Make complete checks and services when the equipment is shut down.

Item No.	Interval	Location	Procedure	Not Fully Mission Capable If:
		Item to Check/Service		
1	Monthly	Refrigeration Unit Exterior	Service the doors and cover by lubricating the hinges (fig.4-7). <ul style="list-style-type: none"> a. Apply lubricating oil (MIL-L-2104) sparingly from oil can onto the hinge moving joint surfaces. b. Wipe away excess lubricating oil with a clean rag. 	
		Doors/Cover		
2	Monthly	Barrel Bolts	Service the barrel bolts by lubricating them (fig. 4-7). <ul style="list-style-type: none"> a. Apply lubricating oil (MIL-L-2104) sparingly from oil can onto the barrel bolt moving joint surfaces. b. Wipe away excess lubricating oil with a clean rag. 	
3	Monthly	Condenser Coil	<ul style="list-style-type: none"> a. Inspect as much of coil as possible, without disassembly, for any evidence of refrigerant leak. If evidence of leak is found, notify direct support maintenance to repair or replace it as necessary. b. Inspect coil for obstructions. If coil is obstructed with dirt or bent fins, remove condenser coil guard (para 4.17) and clean or straighten fins as needed. 	Condenser coil is obstructed or evidence of leak is found.

Table 4-1. Preventive Maintenance Checks and Services for Model F9000RE - Continued

Item No.	Interval	Location	Procedure	Not Fully Mission Capable If:
		Item to Check/Service		
3- Cont			 <p>(1) Clean coil if dirty.</p> <ul style="list-style-type: none"> (a) Mix a small quantity of detergent with water to make a wash solution. (b) Dip a scrub brush in the wash solution and clean the fins by carefully brushing up and down. Continue to dip and brush as needed to loosen dirt. (c) Rinse the scrub brush with clean water and rinse the fins by carefully brushing up and down. Continue to rinse and brush as needed to clean the coil. <p>(2) If fins are bent, carefully straighten them using fin comb.</p> <p>(3) Install condenser coil guard (para 4.17).</p>	

Table 4-1. Preventive Maintenance Checks and Services for Model F9000RE - Continued

Item No.	Interval	Location	Procedure	Not Fully Mission Capable If:
		Item to Check/Service		
4	Monthly	Evaporator Coil	<p style="text-align: center;">NOTE</p> <p style="text-align: center;">The side panels must be removed for the following monthly PMCS.</p> <p>a. Inspect as much of coil as possible, without disassembly, for any evidence of refrigerant leak. If evidence of leak is found, notify direct support maintenance to repair or replace it as necessary.</p> <p>b. Inspect coil for obstructions. If coil is obstructed with dirt or bent fins, remove side panels (para 4.16) and clean or straighten fins as needed.</p> <div style="text-align: center;">  <p>The diagram shows a perspective view of an evaporator coil assembly. It consists of a rectangular metal frame with a series of vertical fins. A label 'EVAPORATOR COIL' with a leader line points to the coil structure. The assembly is shown partially disassembled, with one side panel removed to reveal the internal coil.</p> </div> <p>(1) Clean coil if dirty.</p> <p>(a) Mix a small quantity of detergent with water to make a wash solution.</p> <p>(b) Dip a scrub brush in the wash solution and clean the fins by carefully brushing up and down. Continue to dip and brush as needed to loosen dirt.</p>	Evaporator coil is obstructed or evidence of leak is found.

Table 4-1. Preventive Maintenance Checks and Services for Model F9000RE - Continued

Item No.	Interval	Location	Procedure	Not Fully Mission Capable If:
		Item to Check/Service		
4-Cont			<p>(c) Rinse the scrub brush with clean water and rinse the fins by carefully brushing up and down. Continue to rinse and brush as needed to clean the coil.</p> <p>(2) If fins are bent, carefully straighten them using fin comb.</p>	
5	Monthly	<p>Refrigeration Unit Interior</p> <p>Flange Bearings</p>	<p>Service the flange bearings by lubricating them (fig. 4-7).</p> <p>a. Wipe grease fitting with a clean rag.</p> <p>b. Pump grease gun handle until a flow of clean grease (MIL-G-23549) comes out nozzle.</p> <p>c. Attach grease gun nozzle to grease fitting and pump handle until grease just begins coming out around bearing.</p> <p>d. Remove grease gun nozzle and wipe away excess grease with a clean rag.</p>	
6	Monthly	Evaporator Fan	<p>a. Inspect evaporator fan for cracks and tears. Inspect for loose connection to fan drive shaft. If loose, tighten to shaft. If damaged, replace (para 4.37).</p> <p>b. Install side panels (para 4.16).</p>	Fan is cracked, torn, or loose.

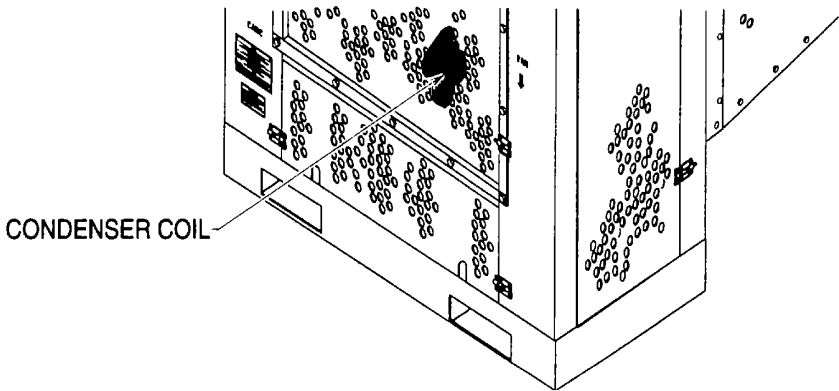
Table 4-1. Preventive Maintenance Checks and Services for Model F9000RE - Continued

Item No.	Interval	Location	Procedure	Not Fully Mission Capable If:
		Item to Check/Service		
7	Semi-Annually	<p>Refrigeration Unit Interior</p> <p>AC Motor</p>	 <p>EVAPORATOR FAN</p> <p>Inspect AC motor for evidence of overheating in the form of discolored or blistered paint. Check for loose or missing mounting hardware and loose shaft. If evidence of overheating is observed or the shaft is loose, replace motor (para 4.34). If mounting hardware is loose or missing, tighten or replace as necessary (para 4.34).</p>  <p>AC MOTOR</p>	<p>Evidence of overheating is found. Shaft is loose, mounting hardware is loose or missing.</p>

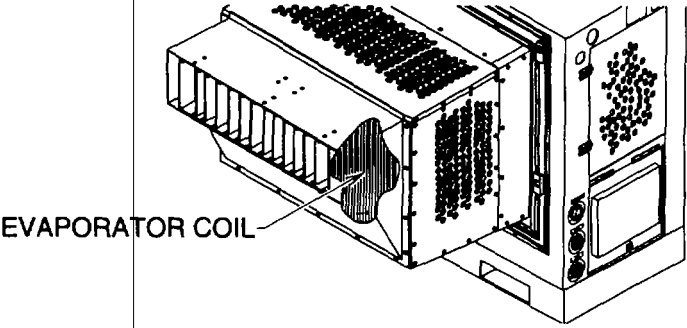
Table 4-1. Preventive Maintenance Checks and Services for Model F9000RE - Continued

Item No.	Interval	Location	Procedure	Not Fully Mission Capable If:
		Item to Check/Service		
8	Semi-Annually	Control Box Interior	<p style="text-align: center;">NOTE</p> <p style="text-align: center;">The control box cover must be open, and the circuit breaker cover loose, for all interior control box PMCS.</p> <p>a. Open the control box cover (para 4.24) and remove the circuit breaker cover from the control box (para 4.22). Do not disconnect any wire leads.</p> <p>b. Check for loose or missing fuse block mounting hardware, loose wire leads, and loose fuse block clips. If mounting hardware or leads are loose, tighten or replace as necessary (para 4.24). If fuse block clips are loose, replace fuse block.</p> <p>c. Check each fuse for broken link or discoloration of case. Replace fuse if link is broken or case is discolored (para 4.24).</p>	Wire lead or fuse clip loose. Fuse link is broken or fuse case is discolored.
		Fuses		

Table 4-1. Preventive Maintenance Checks and Services for Model F9000RE - Continued

Item No.	Interval	Location	Procedure	Not Fully Mission Capable If:
		Item to Check/Service		
9	Semi-Annually	Motor Starter	<p>a. Check for loose or missing mounting hardware and wire terminals. Tighten or replace as necessary (para 4.25).</p> <p>b. Inspect case for cracks, breaks, or evidence of overheating. Replace if damaged (para 4.25).</p>	Mounting hardware or wire terminals are loose. Case is damaged.

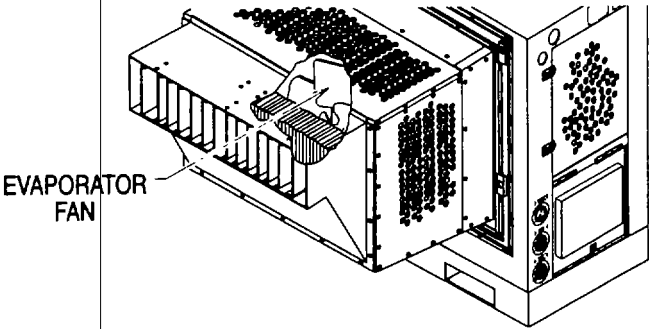
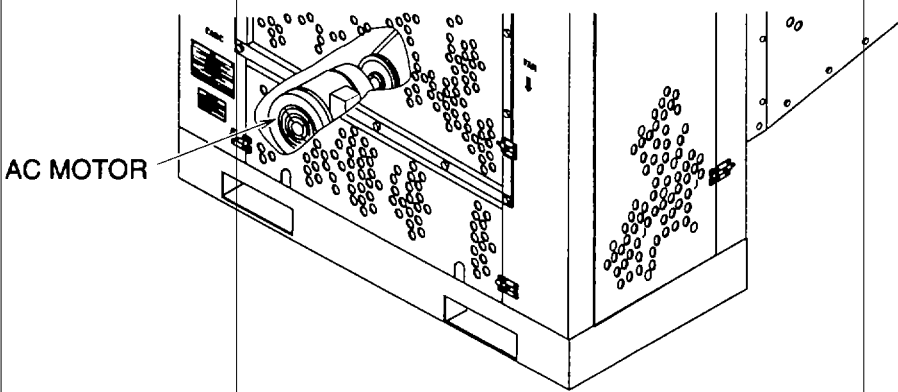
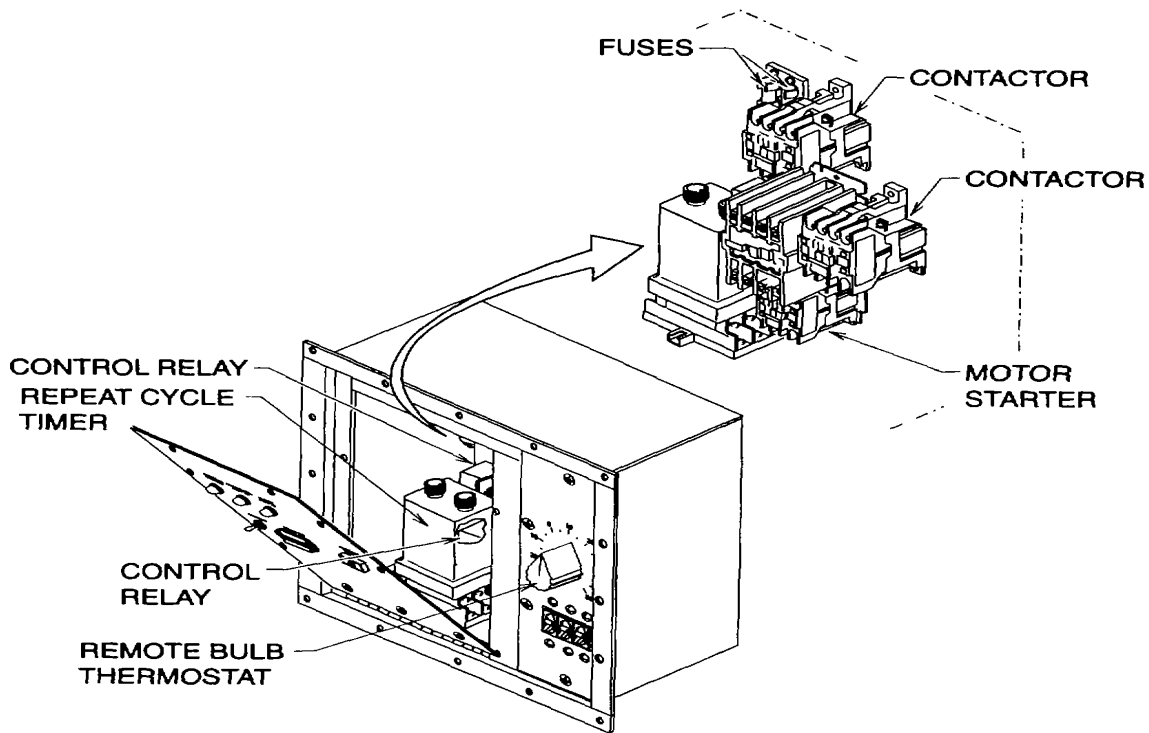

Table 4-1. Preventive Maintenance Checks and Services for Model F9000RE - Continued

Item No.	Interval	Location	Procedure	Not Fully Mission Capable If:
		Item to Check/Service		
10	Semi-Annually	Control Relays	<ul style="list-style-type: none"> a. Check for loose or missing mounting hardware and wire terminals. Tighten or replace as necessary (para 4.28). b. Inspect case for cracks, breaks, or evidence of overheating. Replace if damaged (para 4.28). 	Mounting hardware or wire terminals are loose. Case is damaged.
11	Semi-Annually	Contractors (Power Relays) and Auxiliary Contact	<ul style="list-style-type: none"> a. Check for loose or missing mounting hardware and wire terminals. Tighten or replace as necessary (para 4.26 & 4.27). b. Inspect case for cracks, breaks, or evidence of overheating. Replace if damaged (para 4.26 & 4.27). 	Mounting hardware or wire terminals are loose. Case is damaged.
12	Semi-Annually	Defrost Timer	<ul style="list-style-type: none"> a. Check for loose or missing mounting socket hardware and wire terminals. Tighten or replace as necessary (para 4.29). b. Inspect case and mounting socket for cracks, breaks, or evidence of overheating. Replace if damaged (para 4.29). c. Check and adjust the timer controls if needed (para 4.29). 	Mounting hardware or wire terminals are loose. Case is damaged.
13	Semi-Annually	Thermostat and Switch (Heater Lockout)	<ul style="list-style-type: none"> a. Check for loose or missing mounting hardware and wire terminals. Tighten or replace as necessary (para 4.23). b. Inspect for kinked or broken sensing bulb capillary line. If damaged, replace thermostat (para 4.23). c. Check for loose switch (heater lockout) and loose or missing wire terminals. Tighten or replace as necessary (para 4.23). d. Install the circuit breaker cover onto the control box (para 4.23). Close the control box cover (para 4.24). 	Sensing bulb capillary line is kinked or broken. Mounting hardware or wire terminals are loose. Switch (heater lockout) is loose.

Table 4-1. Preventive Maintenance Checks and Services for Model F9000RE - Continued

Item No.	Interval	Location	Procedure	Not Fully Mission Capable If:
		Item to Check/Service		
14	Semi-Annually	Refrigeration Unit Exterior Thermostatic Switch	<ul style="list-style-type: none"> a. Remove the heater frame (para 4.41). b. Remove mounting bracket from shroud (para 4.42). Do not remove wire leads. c. Inspect for frayed or broken wire leads. If damaged, repair or replace as needed (para 4.42). d. Check that the mounting hardware is secure and tighten if loose. e. Install mounting bracket onto shroud (para 4.42). f. Install the heater frame (para 4.41). <p style="text-align: center;">NOTE</p> <p style="text-align: center;">The side panels must be removed for the following semi-annual PMCS.</p>	Wire lead frayed or broken.
15	Semi-Annually	Temperature Switch	<ul style="list-style-type: none"> a. Remove the side panel (para 4.16). b. Inspect for frayed or broken wire leads. If damaged, repair or replace as needed (para 4.43). c. Check that the mounting hardware is secure and the switch is in contact with the tubing. Tighten the mounting hardware if loose. 	Wire lead frayed or broken. Temperature switch loose on tubing.

Table 4-1. Preventive Maintenance Checks and Services for Model F9000RE - Continued

Item No.	Interval	Location	Procedure	Not Fully Mission Capable If:
		Item to Check/Service		
16	Semi-Annually	Heat Exchanger	<p>Inspect the heat exchanger for dents or evidence of refrigerant leak. If damaged or evidence of leaking found, notify direct support maintenance to replace it.</p>	Heat exchanger is dented or evidence of leak is found.

Table 4-1. Preventive Maintenance Checks and Services for Model F9000RE - Continued

Item No.	Interval	Location	Procedure	Not Fully Mission Capable If:
		Item to Check/Service		
17	Semi-Annually	Electric Heaters	<ol style="list-style-type: none"> a. Remove the heater frame (para 4.41). b. Inspect for frayed or broken wire leads. If damaged, repair or replace as needed (para 4.41). c. Check that the mounting hardware is secure and tighten if loose. d. Inspect heater sheath for deformation, burnt spots, or cracks. If damaged, replace heater (para 4.41). e. Install the heater frame (para 4.41). 	Wire lead frayed or broken, or sheath damaged.
				
18	Semi-Annually	Expansion Valve	<ol style="list-style-type: none"> a. Inspect the expansion valve for evidence of refrigerant leak. If evidence or leak is found, notify direct support maintenance to replace it. b. Inspect the sensing bulb capillary line for cracks, kinks, or breaks. If damaged, notify direct support maintenance to replace the expansion valve. c. Check that the sensing bulb mounting hardware is secure and the bulb is in contact with the tubing. Tighten the mounting hardware if loose. d. Install the side panels (para 4.16). 	Evidence of leak is found, sensing bulb is loose on tubing, or capillary line is kinked or broken.

Table 4-1. Preventive Maintenance Checks and Services for Model F9000RE - Continued

Item No.	Interval	Location	Procedure	Not Fully Mission Capable If:
		Item to Check/Service		
19	Annually	<p>Refrigeration Unit Interior</p> <p>Wires, Cables, and Harnesses</p>	<p>Inspect for frayed or broken wire leads. If damaged, repair or replace as needed (para 4.18).</p>	<p>Wire lead frayed or broken.</p>

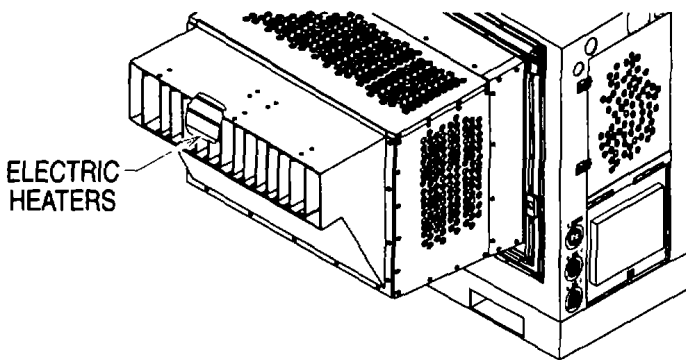
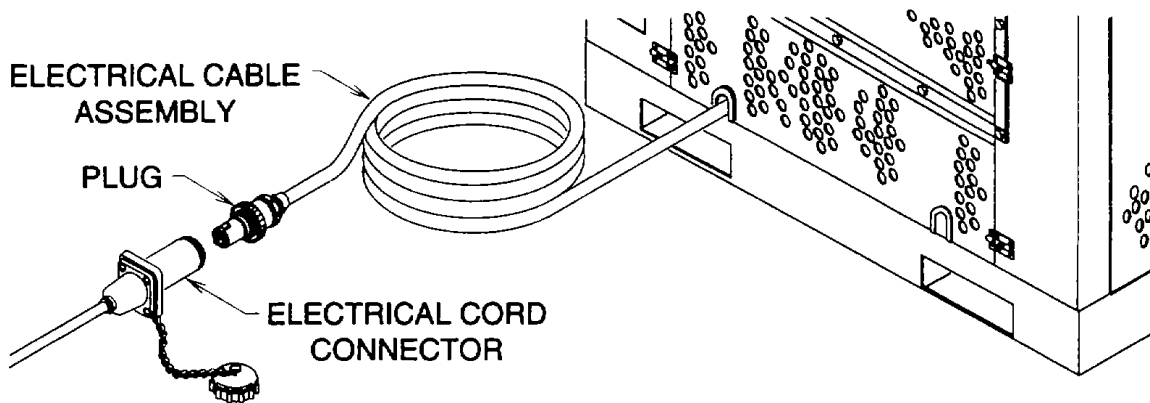

4.12 MANDATORY REPLACEMENT PARTS.

The table below lists all items that must be replaced during PMCS whether they have failed or not. The table reflects the interval at which these items must be replaced whether hardtime maintenance or on condition maintenance is the determining factor.

Table 4-2. Monthly Mandatory Replacement Parts

<u>Item No.</u>	<u>Part Number</u>	<u>National Stock Number</u>	<u>Nomenclature</u>	<u>Qty</u>
1	500K1950-3		Washer, Lock	16
2	500K1950-2		Washer, Lock	32

Table 4-3. Semi-Annually Mandatory Replacement Parts

<u>Item No.</u>	<u>Part Number</u>	<u>National Stock Number</u>	<u>Nomenclature</u>	<u>Qty</u>
1	500K1950-3		Washer, Lock	12
2	500K1972-2		Self Locking Nut	16
3	500K1950-2		Washer, Lock	32

SECTION V UNIT TROUBLESHOOTING INSTRUCTIONS

4.13 TROUBLESHOOTING.

The following procedures are listed in order of the most probable malfunctions. Each malfunction is followed by test or inspection procedures in logical order to isolate and identify the fault and actions required to correct it. This section cannot list all the possible malfunctions that may occur with the equipment. If a malfunction occurs that is not listed or actions listed do not correct a malfunction, notify your supervisor.

a. Refrigeration Unit Does Not Start.

TEST FUSES (PARA 4.24) AND REPLACE IF NEEDED.
DOES REFRIGERATION UNIT START?

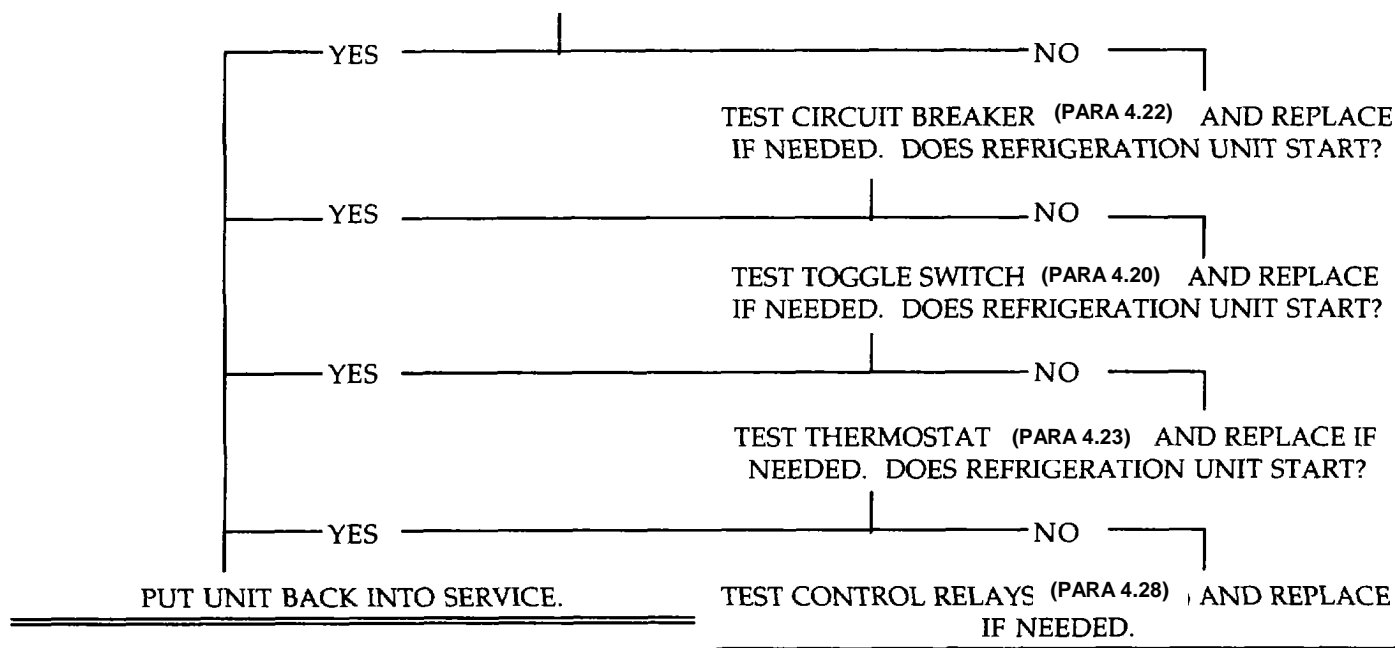

b. Circuit Breaker Trips.

TEST AC MOTOR (PARA 4.34) AND REPLACE IF
NEEDED. DOES REFRIGERATION UNIT START?

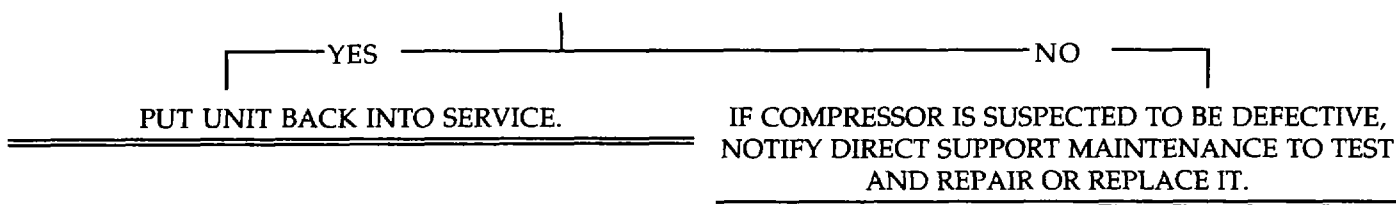

c. Reset Button Trips.

TEST MOTOR STARTER (PARA 4.25) AND REPLACE
STARTER OR THERMAL OVERLOAD HEATER IF
NEEDED. DOES REFRIGERATION UNIT START?

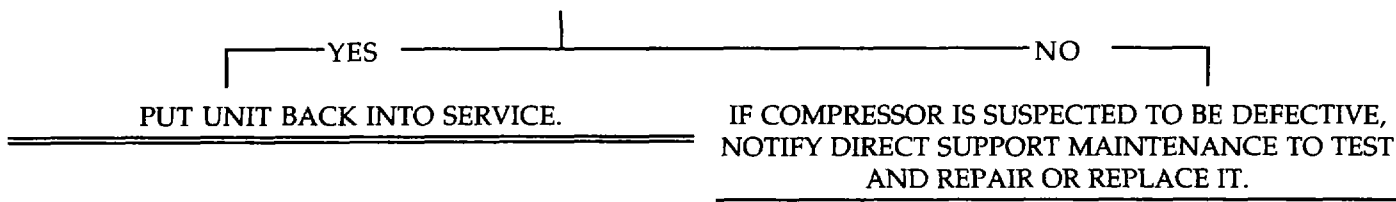

- d. Thermometer (Refrigerator Temperature) Indicates More Than 15° F (7° C) Above or Below Remote Bulb Thermostat (Temperature Control) Setting.

TEST THERMOSTAT (PARA 4.23) AND REPLACE IF NEEDED. OPERATE UNIT (PARA 2.5). DOES REFRIGERATOR TEMPERATURE INDICATE WITHIN 15° F (7° C) OF TEMPERATURE CONTROL ?

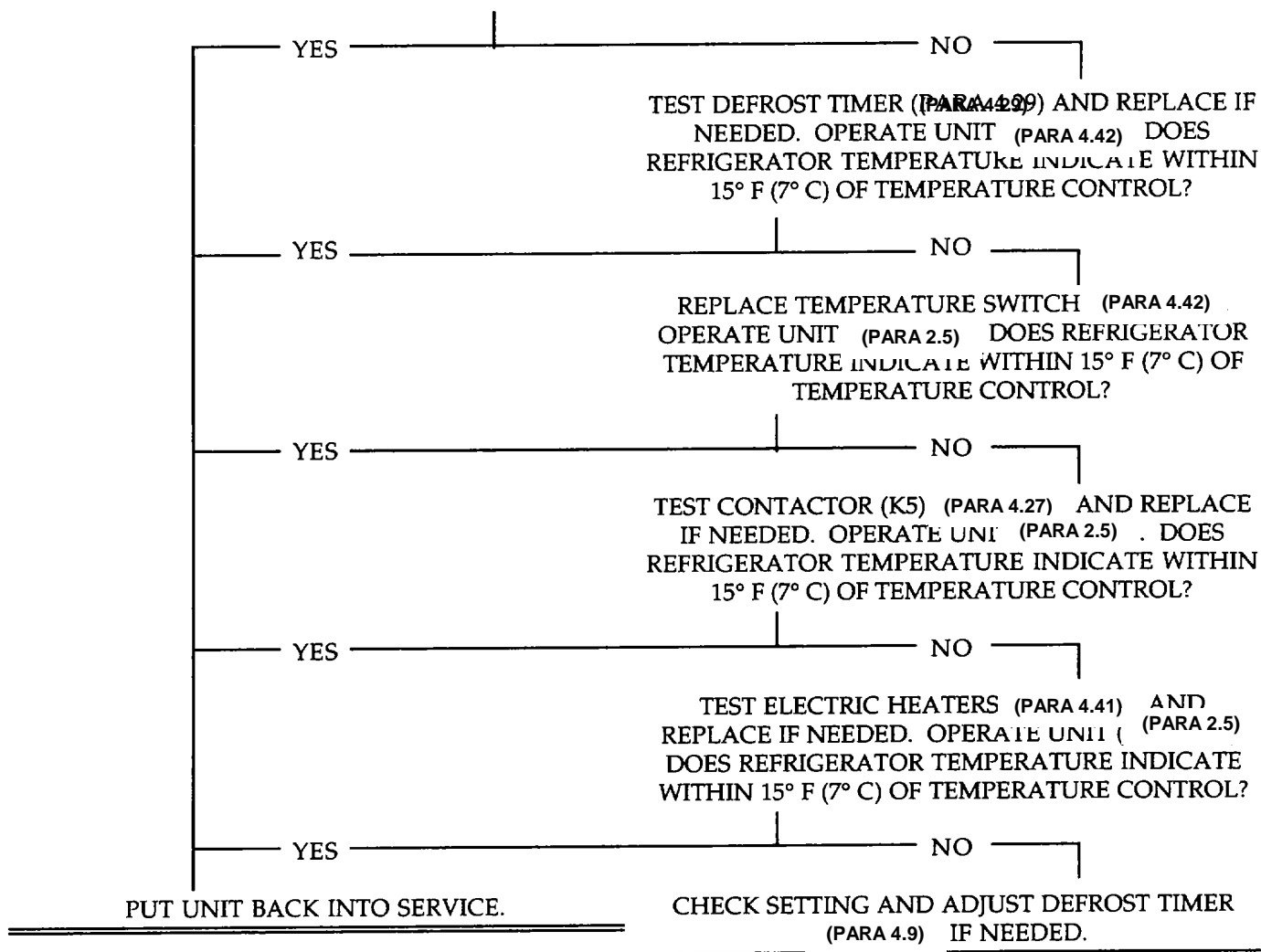

NOTE

The following indications apply to conditions only when the REFRIGERATION CYCLE ON lamp is illuminated

- e. Pressure Gage (Discharge Pressure) Indicates Above 250 psi (1725 kPa).

OPEN ALL REFRIGERATION VALVES (PARA 4.8). IF ANY VALVES WERE CLOSED, OPERATE UNIT (PARA 2.5). IS DISCHARGE PRESSURE BELOW 250 PSI (1725 kPa)?

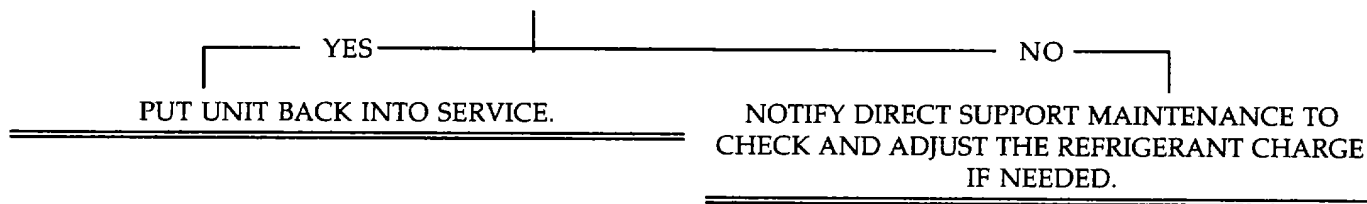

- f. Pressure Gage (Discharge Pressure) Indicates Below 165 psi (1138.5 kPa).

OPEN ALL REFRIGERATION VALVES (PARA 4.8). IF ANY VALVES WERE CLOSED, OPERATE UNIT (PARA 2.5). IS DISCHARGE PRESSURE ABOVE 165 PSI (1138.5 kPa)?

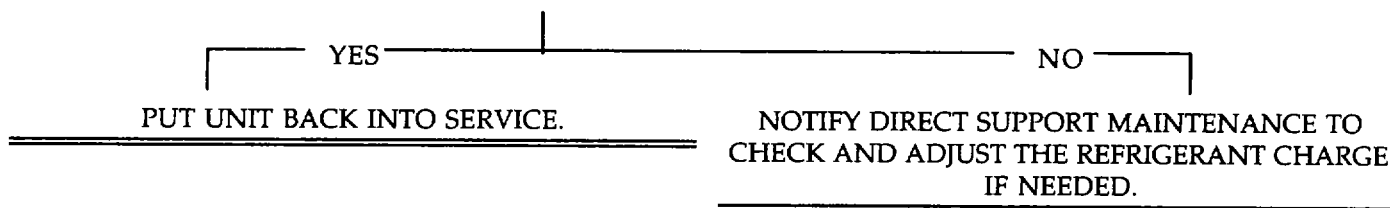

- g. Compound Gage (Suction Pressure) Indicates Above 15 psi (103.5 kPa).

OPEN ALL REFRIGERATION VALVES (PARA 4.8). IF ANY VALVES WERE CLOSED, OPERATE UNIT (PARA 2.5). IS SUCTION PRESSURE BELOW 15 PSI (103.5 kPa)?

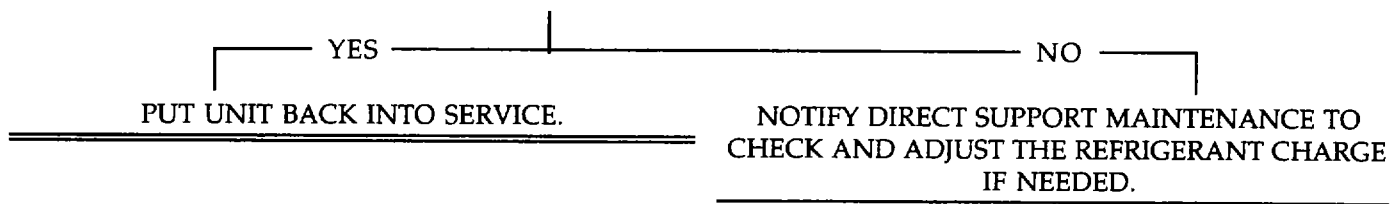

h. Compound Gage (Suction Pressure) Indicates Below 0 psi (0 kPa).

OPEN ALL REFRIGERATION VALVES (PARA 4.8). IF ANY VALVES WERE CLOSED, OPERATE UNIT (PARA 2.5). IS SUCTION PRESSURE ABOVE 0 PSI (0 kPa)?

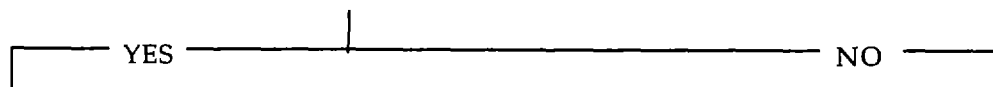

PUT UNIT BACK INTO SERVICE.

NOTIFY DIRECT SUPPORT MAINTENANCE TO CHECK AND ADJUST THE REFRIGERANT CHARGE IF NEEDED.

i. Compressor Operates For Short Period Then Stops.

OPERATE REFRIGERATION UNIT (PARA 2.5) AND OBSERVE PRESSURE GAGES. ARE PRESSURES WITHIN NORMAL OPERATING RANGE?

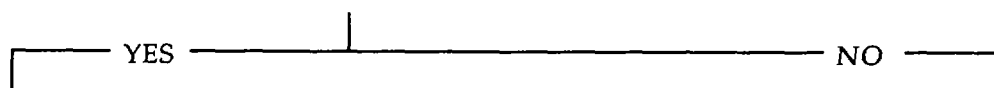

CHECK AND ADJUST DUAL PRESSURE CONTROL SWITCH (PARA 4.8).

SEE APPROPRIATE TROUBLESHOOTING PROCEDURE AS INDICATED.

SECTION VI UNIT MAINTENANCE INSTRUCTIONS

4.14 TOP ACCESS PANEL REPLACEMENT.

This task covers: a. Removal b. Installation

INITIAL SETUP

Equipment Conditions:
Refrigeration unit shut down (para 2.7) and power

General Safety Instructions:

WARNING

High voltage and exposed rotating parts are used in the refrigeration unit. Personal injury can result if power is connected.

disconnected.

Materials/Parts:

Lock Washers (12)
1, Appendix G

- a. Removal. Remove 12 bolts (1), lock washers (2), and top access panel (3). Discard lock washers.
- b. Installation. Install top access panel (3), 12 new lock washers (2), and bolts (1).

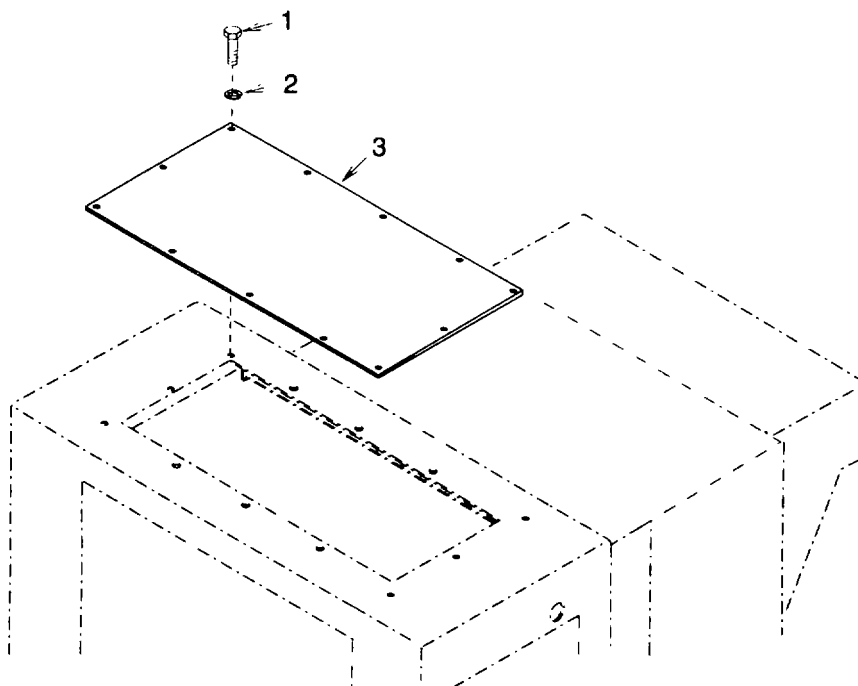

Figure 4-8. Top Access Panel

NOTE

FOLLOW-ON MAINTENANCE:
Connect power and put unit back into service.

4.15 TOP PANEL (EVAPORATOR) REPLACEMENT.

This task covers: a. Removal b. Installation

INITIAL SETUP

Equipment Conditions:
Refrigeration unit shut down (para 2.7) and power

disconnected.

Materials/Parts:

Lock Washers (8)
3, Appendix G

General Safety Instructions:

WARNING

High voltage and exposed rotating parts are used in the refrigeration unit. Personal injury can result if power is connected.

- a. Removal. Remove eight screws (1), lock washers (2), flat washers (3) and top panel (4). Discard lock washers.
- b. Installation. Install top panel (4), seven flat washers (3), new lock washers (2), and screws (1).

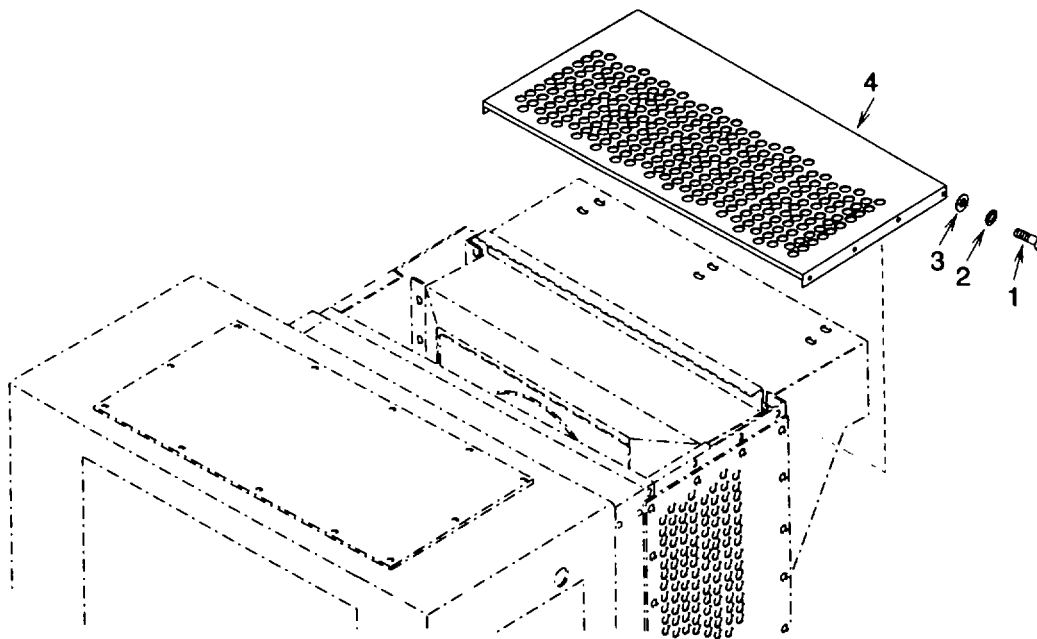

Figure 4-9. Top Panel

NOTE

FOLLOW-ON MAINTENANCE:
Connect power and put unit back into service.

4.16 SIDE PANELS (EVAPORATOR) REPLACEMENT.

This task covers: a. Removal b. Installation

INITIAL SETUP

Equipment Conditions:
Refrigeration unit shut down (para 2.7) and power

disconnected.

Materials/Parts:
Lock Washers (12)
3, Appendix G

General Safety Instructions:

WARNING

High voltage and exposed rotating parts are used in the refrigeration unit. Personal injury can result if power is connected.

NOTE

The left and right side panels are identical. The following procedures cover replacement of only one panel but are typical for both

- a. Removal. Remove 12 screws (1), lock washers (2), flat washers (3) and side panel (4). Discard lock washers.
- b. Installation. Install side panel (4), 12 flat washers (3), new lock washers (2), and screws (1).

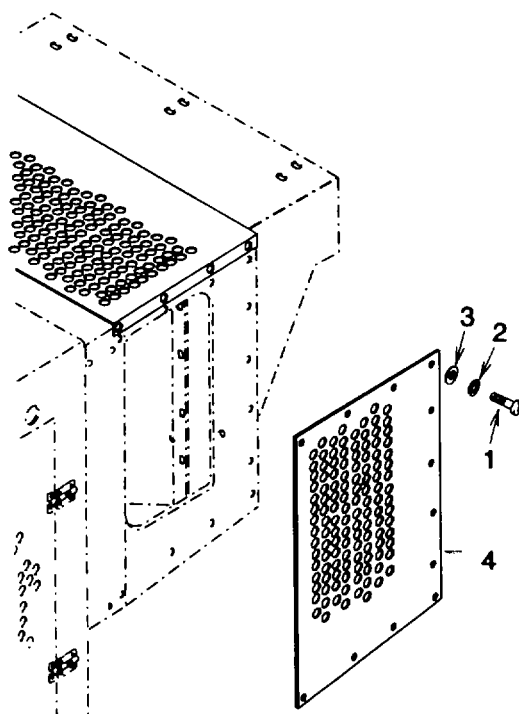

Figure 4-10. Side Panels

NOTE

FOLLOW-ON MAINTENANCE:
Connect power and put unit back into service.

4.17 CONDENSER COIL GUARD REPLACEMENT.

This task covers: a. Removal b. Installation

INITIAL SETUP

Equipment Conditions:

Refrigeration unit shut down (para 2.7) and power disconnected.

General Safety Instructions:

WARNING

High voltage and exposed rotating parts are used in the refrigeration unit. Personal injury can result if power is connected.

Materials/Parts:

Lock Washers (16)

1, Appendix G

-
- a. Removal. Remove 16 bolts (1), lock washers (2), and condenser coil guard (3). Discard lock washers.
 - b. Installation. Install condenser coil guard (3), 16 new lock washers (2), and bolts (1).

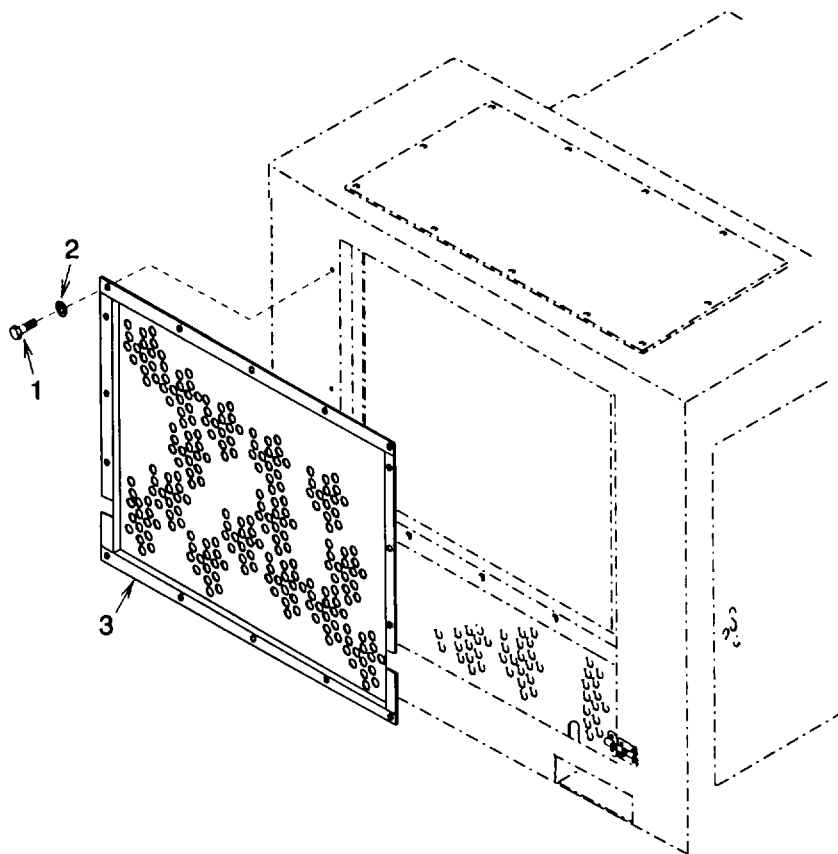

Figure 4-11. Condenser Coil Guard

NOTE

FOLLOW-ON MAINTENANCE:
Connect power and put unit back into service.

4.18 WIRES. CABLES AND HARNESSES TESTING, REPAIR, AND REPLACEMENT.

This task covers: a. Testing b. Repair c. Removal d. Installation

INITIAL SETUP

Tools:

Heat Gun
power
3, Section III, Appendix B

Materials/Parts:

Wire (As Required)
Insulation Sleeving (As Required)
Figure F-31, Appendix F
Solder
Figure F-31, Appendix F
Solder
8, Appendix E
Flux
Tiedown
9, Appendix E
Tiedown Strap(s) (As Required)
24, Appendix
Marker Tag(s) (As Required)
7, Appendix E
Silicone RTV
20, Appendix E

Equipment Conditions:

Refrigeration unit shut down (para 2.7) and disconnected.
Side condenser doors open.
Side panel (control box side) removed (para 4.16).
Control box cover door raised and latched.
Heater frame removed (para 4.41).

General Safety Instructions:

WARNING

High voltage and exposed rotating parts are used in the refrigeration unit. Personal injury can result if power is connected.

a. Testing.

- (1) Be sure power has been disconnected at the source and remove six screws (1). Open control box cover (2).
- (2) Tag and disconnect wire leads from components as necessary to isolate the wire or harness being tested.
- (3) Using multimeter set to measure continuity, check each end of the wire lead(s).
- (4) Replace any wire lead(s) that do not show continuity.
- (5) Connect wire lead(s) per tag and wiring diagram (fig. 1-4).

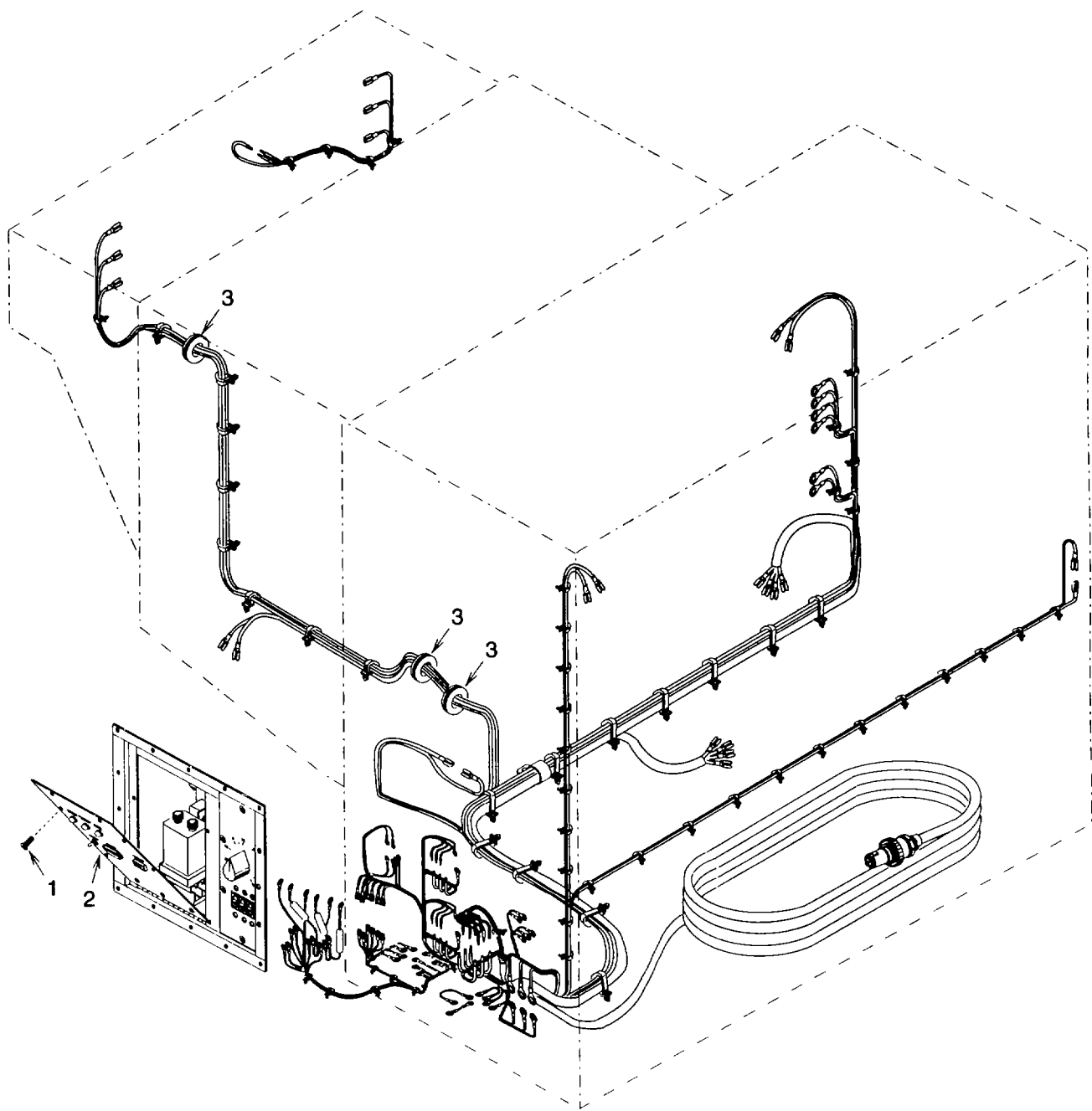

Figure 4-12. Wire Cables and Harnesses

4.18 WIRES, CABLES AND HARNESSSES TESTING. REPAIR, AND REPLACEMENT. - Continued

- b. Repairs. Repairs can be performed to replace terminal ends or to splice wire when cut.

WARNING

Solder and flux contain materials which are hazardous to health. Avoid breathing vapors or fumes from soldering operations. Perform operations only in well ventilated areas. Wash hands with soap and water after handling solder and flux. Wear thermal gloves and protective goggles or face shield to protect against burns

- (1) Soldering Connections. Wire connections must be made mechanically sound before they are soldered; solder alone does not provide sufficient strength to prevent breakage. Joining surfaces of connections to be soldered must be dean and bright. Flux should be brushed onto the joint before soldering. Wires should always be heated to the point at which the solder will melt completely and flow into all parts of the joint. Excessive build up of solder "gobs" on the joint should be avoided or removed
- (2) Insulating Joints. The preferred method of insulating electrical joints is by the use of heat-shrink tubing. To apply, cut a piece of heat-shrink tubing of suitable diameter to a length of 1 inch (2. 5 cm) for covering joints at terminals or connectors, or to a length about 1/2 inch (1. 3 cm) longer than the joint to be insulated. Slide the tubing over the wire before making the joint. After the joint is made, slide the tubing so that it covers the joint and shrink in place with moderate heat
- (3) Splicing Wire. To repair broken or cut wires that are otherwise sound, the mating ends can be stripped and spliced. Solder and apply insulation as described above
- (4) Crimping Terminals. To install a terminal on the end of a wire, strip 1/4-1/2 inch (0. 6-1. 3 cm) of insulation from the end of the wire and apply a one inch (2. 4 cm) piece of heat shrink tubing (if the terminals are of the uninsulated type). Insert wire-end into the shank of the terminal. Crimp the shank and install heat-shrink tubing, if necessary

NOTE

Preferred repair methods consist of replacing wires, terminals, connectors, etc. , rather than splicing wires, bending ends to form terminals, and other make shift procedures, although the latter may be appropriate for emergency field repairs

- (5) Determine the proper size and length of the wire, or terminal, or connector to be used for replacement by referring to the wire list (table 4-4), and to the wiring diagram (fig. 1-4)

Table 4-4. Wire List

TERMINATION		TERMINATION		AWG WIRE SIZE	LENGTH	
FROM	TERMINAL TYPE	TO	TERMINAL TYPE		IN.	CM
CB1-A2	MS25036-112	K1-L1		12 AWG-WHT	36.00	91.44
CB1-B2	MS25036-112	K1-L2		12 AWG-WHT	36.00	91.44
CB1-C2	MS25036-112	K1-L3		12 AWG-WHT	36.00	91.44
K1-L1		K2-L1		14 AWG-WHT	11.50	29.21
K1-L2		K2-L2		14 AWG-WHT	11.50	29.21
K1-L3		K2-L3		14 AWG-WHT	11.50	29.21
K2-L1		K5-L1		14 AWG-WHT	13.00	33.02
K2-L2		K5-L2		14 AWG-WHT	14.00	35.66
K2-L3		K5-L3		14 AWG-WHT	15.00	38.10
OL1-T1		B1-B	12712937-1 (19200)	SEE NOTE 1	120.00	304.80
			12712936 (19200)	BLK		
OL2-T2		B1-2	12712937-1 (19200)	SEE NOTE 1	120.00	304.80
			12712936 (19200)	WHT OL3-T3	B1-3	
			12712937-1 (19200)	SEE NOTE 1	120.00	304.80
			12712936 (19200)	RED GND		
	MS25036-112	B1-GND	MS25036-112	SEE NOTE 1	120.00	304.80
				GRN		
K1-A1		M1-1	MS25036-103	18 AWG-WHT	24.00	60.96
K1-A2		K2-A2		18 AWG-WHT	12.00	30.48
K1-A2		F2-2	MS25036-102	18 AWG-WHT	20.00	50.80
K1-96		S5-M	MS25036-102	18 AWG-WHT	120.00	304.80
K1-95		S5-2	MS25036-102	18 AWG-WHT	120.00	304.80
K2-T1		B2-1	12712937-1 (19200)	SEE NOTE 2	120.00	304.80
			12712936 (19200)	BLK		
K2-T2	B2-3	12712937-1 (19200)	(19200)	SEE NOTE 2	120.00	304.80
		12712936 (19200)	(19200)	RED		
K2-T3	B2-2	12712937-1 (19200)	(19200)	SEE NOTE 2	120.00	304.80
		12712936 (19200)	(19200)	WHT		
GND	MS25036-108	B2-GND	MS25036-108	SEE NOTE 2	120.00	304.80
				GRN		
K2-A1		TM1-1	MS25036-102	18 AWG-WHT	12.00	30.48
K2-A2	B-972 (1W654)	K3-B	13216E6191-1 (97403)	18 AWG-WHT	12.00	30.48
S7-NO	B-972	(1W654)	MS25036-102	18 AWG-WHT	120.00	304.80
S1-2	MS25036-102	K3-7	13216E6191-1 (97403)	18 AWG-WHT	24.00	60.96
K3-7	13216E6191-1 (97403)	K4-7	13216E6191-1 (97403)	18 AWG-WHT	12.00	30.48
F2-2	MS25036-149	L1-B	12712937-2 (19200)	18 AWG-WHT	120.00	304.80
			12712936 (19200)			
OL3-T3		S5-V	MS25036-102	18 AWG-WHT	120.00	304.80

Table 4-4. Wire List Continued

TERMINATION		TERMINATION		AWG WIRE SIZE	LENGTH	
FROM	TERMINAL TYPE	TO	TERMINAL TYPE		IN.	CM
F2-2	MS25036-149	L2-B	12712937-2 (19200) 12712936 (19200)	18 AWG-WHT	120.00	304.80
K3-4		S2-LINE	MS25036-102	18 AWG-WHT	120.00	304.80
K3-4		K4-4	MS25036-102	18 AWG-WHT	12.00	30.48
K3-A	13216E6191-1 (97403)	53A-2	MS25036-102	18 AWG-WHT	24.00	60.96
K3-B	13216E6191-1(97403)	K4-B	13216E6191-1 (97403)	18 AWG-WHT	12.00	30.48
K4-7	13216E6191-1 (97403)	K4-9	13216E6191-1 (97403)	18 AWG-WHT	6.00	15.24
K4-A	13216E6191-1 (97403)	M1-1	MS25036-103	18 AWG-WHT	24.00	60.96
K4-6	13216E6191-1 (97403)	TM1-7	MS25036-102	18 AWG-WHT	12.00	30.48
K4-B	13216E6191-1 (97403)	TM1-B	MS25036-102	18 AWG-WHT	12.00	30.48
TM1-4	MS25036-102	DS1-1	MS25036-102	18 AWG-WHT	24.00	60.96
TM1-4	MS25036-102	L2-A	12712937-2 (19200) 12712936 (19200)	18 AWG-WHT	120.00	304.80
TM1-A	MS25036-102	S4-2	12712937-2 (19200) 12712936 (19200)	18 AWG-WHT	120.00	304.80
TM1-6	MS25036-102	S3A-2	MS25036-102	18 AWG-WHT	24.00	60.96
TM1-9	MS25036-102	S1-3	MS25036-102	18 AWG-WHT	24.00	60.96
TM1-B	MS25036-102	M1-2	MS25036-103	18 AWG-WHT	24.00	60.96
S3A-1	MS25036-102	S4-1	12712937-2 (10200) 12712936 (19200)	18 AWG-WHT	120.00	304.80
S3A-1	MS25036-102	S1-3	MS25036-102	18 AWG-WHT	24.00	60.96
S3A-2	MS25036-102	L1-A	12712937-2 (19200) 12712936	18 AWG-WHT	120.00	304.80
S2-M1	MS25036-102	S5-L	MS25036-102	18 AWG-WHT	120.00	304.80
TB1-2	MS25036-112	GND	MS25036-112	12 AWG-WHT	15.00	38.10
F1-2	MS25036-149	S6-C	B-972 (1W654)	18 AWG-WHT	120.00	304.80
S6-NO	B972 (1W654)	S7-C	B-972 (1W654)	18 AWG-WHT	120.00	304.80
K5-L2		FI-1	MS25036-153	10 AWG-WHT	12.00	30.48
K5-L3		F2-1	MS25036153	10 AWG-WHT	12.00	30.48
K2-A2		K5-A2		18 AWG-WHT	12.00	30.48
K5-A1		DS3-1	MS25036-102	18 AWG-WHT	24.00	60.96
K5-A1		S9-2	RAD1823 (59730)	18 AWG-WHT	24.00	60.96
S3B-3	MS25036-102	S9-1	RAD1823 (59730)	18 AWG-WHT	24.00	60.96
TM1-6	MS25036-102	DS2-1	MS25036-102	18 AWG-WHT	15.00	38.10
K5-T1		HRI-A	13216E6191-1 (97403)	12 AWG-WHT	120.00	304.80
K5-T3		HR3-A	13216E6191-1 (97403)	12 AWG-WHT	120.00	304.80
S8-4		HR1-B	13216E6191-1 (97403)	12 AWG-WHT	60.00	152.40
S8-5		HR2-B	13216E6191-1 (97403)	12 AWG-WHT	60.00	152.40

Table 4-4. Wire List - Continued

TERMINATION		TERMINATION		AWG WIRE SIZE	LENGTH	
FROM	TERMINAL TYPE	TO	TERMINAL TYPE		IN	CM
S8-6		HR3-B	13216E6191-1(97403)	12 AWG-WHT	60.00	152.40
K5A-NO		K2-A1		18 AWG-WHT	24.00	60.96
TM1-9		K5A-C		18 AWG-WHT	24.00	60.96

NOTE

- 1 Type SO Cable, Conductor Size 12-4, 20 Amps Minimum Rating 250 Vac.**
- 2 Type SO Cable, Conductor Size 14-4, 15 Amps Minimum Rating 250 Vac.**

c. Removal.

- (1) Tag and disconnect wire lead(s) from component.
- (2) Remove tiedown straps and loosen clamp(s) as necessary to remove wire(s).
- (3) Remove any silicone RTV remaining in evaporator frame grommets (3).

d. Installation.

- (1) Carefully route wire lead(s) through clamp(s) and grommet(s) as necessary.
- (2) Connect wire lead(s) to component using tags and wiring diagram (fig. 1-4). Remove tags.
- (3) Install tiedown straps as necessary and tighten any clamp(s) that were loosened for removal.
- (4) Apply silicone RTV into evaporator frame grommets (3) to seal evaporator enclosure.
- (5) Close control box cover (2). Install six screws (1).

NOTE

FOLLOW-ON MAINTENANCE:
 Close condenser side doors.
 Unlatch and close control box cover door.
 Install heater frame (para 4.41).
 Install side panel (control box side) (para 4.16).
 Connect power and put unit back into service.

4.19 INDICATORS/LAMPS DS1. DS2. OR DS3 TESTING AND REPLACEMENT.

 This task covers:

a. Testing

b. Removal

c. Installation

INITIAL SETUPEquipment Conditions:

Refrigeration unit shut down (para 2.7) and power disconnected.

Control box cover door raised and latched.

Materials/Parts:

Marker Tags (2)
7, Appendix E

General Safety Instructions:**WARNING**

High voltage and exposed rotating parts are used in the refrigeration unit. Personal injury can result if power is connected.

NOTE

The indicators/lamps are identical with the exception of indicator cap color. The following procedures cover testing and replacement of only one indicator/lamp but are typical for all three.

a. Testing. (See Figure 1-4.)

- (1) Be sure power has been disconnected at the source and remove indicator cap (1) and lamp (2).
- (2) Using multimeter set to measure continuity, check lamp (2) continuity between terminals. Continuity should be indicated. If no continuity was indicated, replace lamp.
- (3) If indicator base (3) is damaged, replace it.
- (4) If no failure was indicated, install lamp (2) and indicator cap (1).

b. Removal.

- (1) Be sure power has been disconnected at the source and remove indicator cap (1) and lamp (2).
- (2) Remove six screws (4). Open control box cover (5).

NOTE

Terminal and base mounting hardware is supplied with indicator base.

- (3) Tag wire lead terminals (6) and remove two screws (7) and wire lead terminals.
- (4) Remove nut (8), lock washer (9), and indicator base (3).

c. Installation.

- (1) Install indicator base (3), lock washer (9), and nut (8).
- (2) Using tags and wiring diagram (fig. 1-4), install wire lead terminals (6) and two screws (7). Remove tags.
- (3) Close control box cover (5). Install six screws (4).

NOTE

The red indicator cap is used on the DEFROST IN PROGRESS indicator and the green indicator caps are used on the REFRIGERATOR CYCLE ON and HEATING CYCLE ON indicators.

- (4) Install lamp (2) and indicator cap (1).

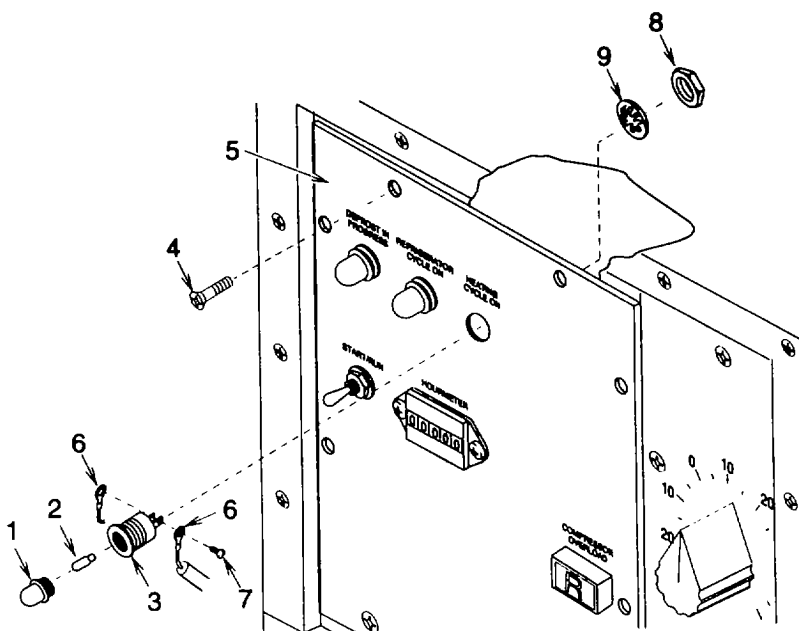

Figure 4-13. Indicator/Lamp

NOTE

FOLLOW-ON MAINTENANCE:
 Unlatch and close control box cover door.
 Connect power and put unit back into service.

4.20 TOGGLE SWITCH S1 TESTING AND REPLACEMENT.

This task covers:

a. Testing

b. Removal

c. Installation

INITIAL SETUPEquipment Conditions:

Refrigeration unit shut down (para 2.7) and power disconnected.

Control box cover door raised and latched.

Materials/Parts:

Marker Tags (2)
7, Appendix E

General Safety Instructions:**WARNING**

High voltage and exposed rotating parts are used in the refrigeration unit. Personal injury can result if power is connected.

a. Testing. (See Figure 1-4.)

- (1) Be sure power has been disconnected at the source and remove six bolts (1). Open control box cover (2)
- (2) Using multimeter set to measure continuity, check toggle switch (3) continuity between terminals 2 to 3 with toggle switch in both START/RUN and OFF position. Continuity should be indicated only when toggle switch is in the START/RUN position. If continuity was indicated in the OFF position or if no continuity was indicated in the START/RUN position, replace toggle switch
- (3) If no failure was indicated, close control box cover (2) and install six screws (1)

b. Removal.

- (1) Be sure power has been disconnected at the source and remove six screws (1). Open control box cover (2)

NOTE

Terminal and mounting hardware is supplied with toggle switch

- (2) Tag wire leads (4) and remove two screws (5), lock washers (6), and wire leads
- (3) Remove nut (7), lock washer (8), retainer (9), and toggle switch (3)

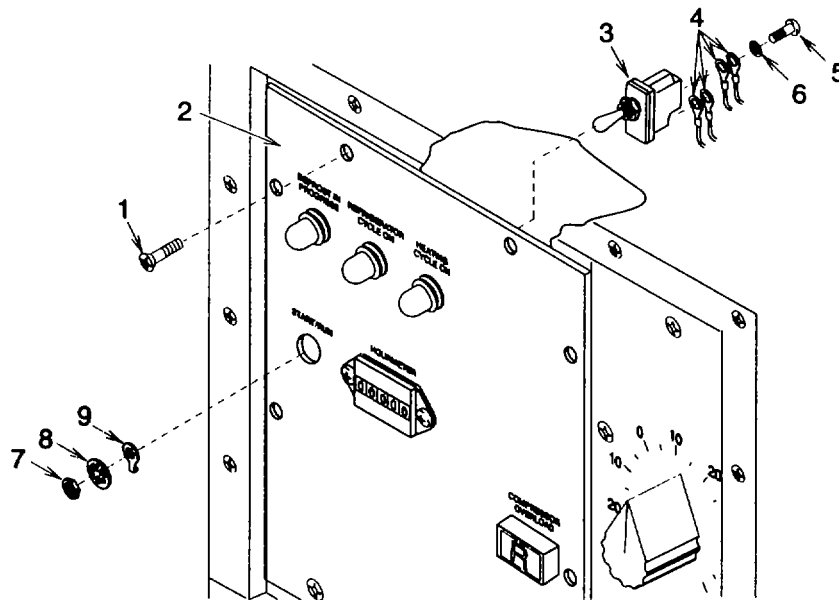

Figure 4-14. Toggle Switch

c. Installation.

- (1) Install toggle switch (3), retainer (9), lock washer (8), and nut (7)
- (2) Using tags and wiring diagram (fig. 1-4), install wire leads (4), two lock washers (6), and screws (5)
Remove tags
- (3) Close control box cover (2). Install six screws (1).

NOTE

FOLLOW-ON MAINTENANCE:
Unlatch and close control box cover door.
Connect power and put unit back into service.

4.21 HOURMETER M1 TESTING AND REPLACEMENT.

 This task covers:

a. Testing

b. Removal

c. Installation

INITIAL SETUPMaterials/Parts:

Self Locking Nuts (2)
8, Appendix G
Marker Tags (2)
7, Appendix E

Equipment Conditions:

Refrigeration unit shut down (para 2.7) and power disconnected.
Control box cover door raised and latched.

General Safety Instructions**WARNING**

High voltage and exposed rotating parts are used in the refrigeration unit. Personal injury can result if power is connected.

a. Testing. (See Figure 1-4.)

- (1) Be sure power has been disconnected at the source and remove six screws (1). Open control box cover (2).
- (2) Using multimeter set to measure continuity, check hourmeter (4) continuity between terminals 1 and 2. Continuity should be indicated. If no continuity was indicated, replace hourmeter.
- (3) If no failure was indicated, close control box cover (2) and install six screws (1).

b. Removal.

- (1) Be sure power has been disconnected at the source and remove six screws (1). Open control box cover (2).

NOTE**Terminal hardware is supplied with hourmeter**

- (2) Tag wire leads (4) and remove two screws (5), lock washers (6), and wire leads.
- (3) Remove two self locking nuts (7), bolts (8), and hourmeter (3). Discard self locking nuts.

c. Installation.

- (1) Install hourmeter (3), two bolts (8), and new self locking nuts (7).
- (2) Using tags and wiring diagram (fig. 1-4), install wire leads (4), two lock washers (6), and screws (5). Remove tags.
- (3) Close control box cover (2). Install two screws (1).

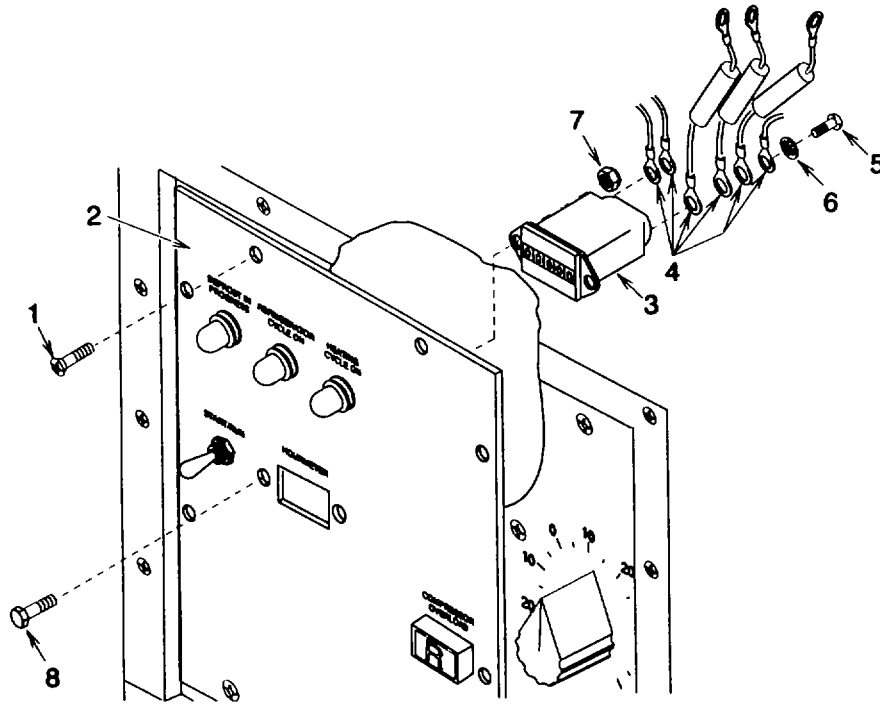

Figure 4-15. Hourmeter

NOTE

FOLLOW-ON MAINTENANCE:
 Unlatch and dose control box cover door.
 Connect power and put unit back into service.

4.22 CIRCUIT BREAKER CB1 TESTING AND REPLACEMENT.

This task covers:

a. Testing

b. Removal

c. Installation

INITIAL SETUPEquipment Conditions:

Refrigeration unit shut down (para 2.7) and power disconnected.

Control box cover door raised and latched.

Materials/Parts:

Lock Washers (6)
6, Appendix G
Marker Tags (6)
7, Appendix E

General Safety Instructions:**WARNING**

High voltage and exposed rotating parts are used in the refrigeration unit. Personal injury can result if power is connected.

a. Testing. (See Figure 1-4.)

- (1) Be sure power has been disconnected at the source and remove six screws (1).
- (2) Carefully pull circuit breaker cover (2) out to expose circuit breaker (3) terminals.
- (3) Using multimeter set to measure continuity, check circuit breaker (3) continuity between terminals A1 to A2, B1 to B2, and C1 to C2 with circuit breaker in both ON and OFF position. Continuity should be indicated only when circuit breaker is in the ON position. If continuity was indicated in the OFF position or if no continuity was indicated in the ON position, Replace circuit breaker.
- (4) If no failure was indicated, carefully push circuit breaker cover (2) into place and install six screws (1).

b. Removal.

- (1) Be sure power has been disconnected at the source and remove six screws (1).
- (2) Remove six screws (4), lock washers (5), and circuit breaker cover (2). Discard lock washers.
- (3) Check gasket (6) material for damage. If damaged, notify direct support maintenance to replace it.

NOTE

Terminal hardware is supplied with circuit breaker.

- (4) Tag wire lead terminals (7) and remove six nuts (8), lock washers (9), and wire lead terminals.

c. Installation.

- (1) Using tags and wiring diagram (fig. 1-4), install wire lead terminals (7), six lock washers (9), and nuts (8). Remove tags.
- (2) Install circuit breaker cover (2), six new lock washers (5), and screws (4).
- (3) Carefully push circuit breaker cover (2) into place and install six screws (1).

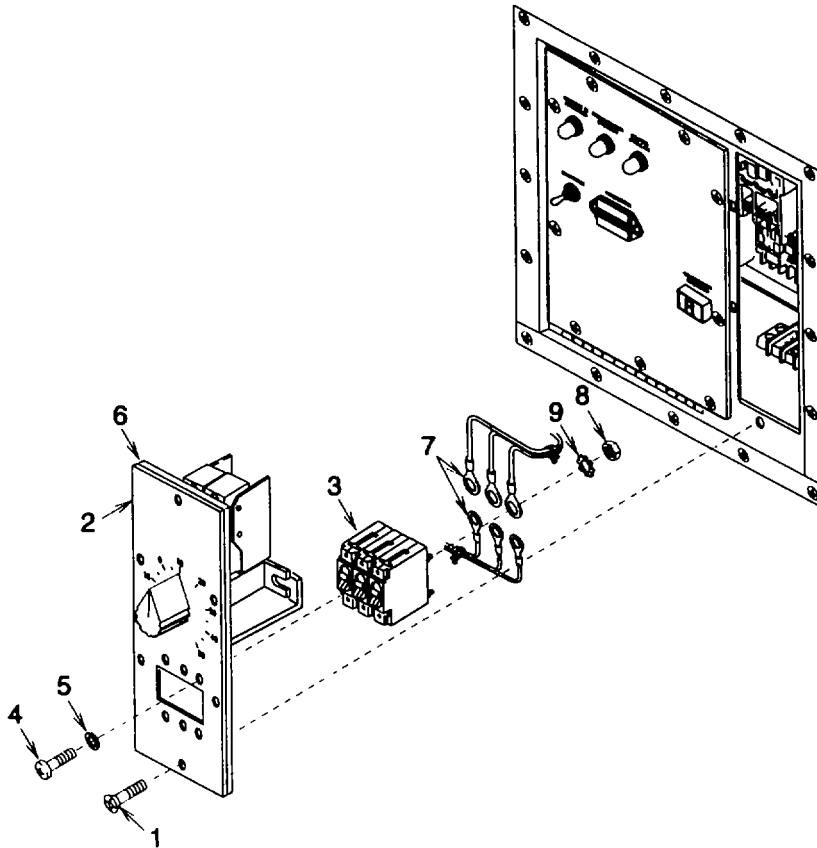

Figure 4-16. Circuit Breaker

NOTE

FOLLOW-ON MAINTENANCE:
 Unlatch and close control box cover door.
 Connect power and put unit back into service.

4.23 THERMOSTAT S3 OR SWITCH (HEATER LOCKOUT) S9 TESTING AND REPLACEMENT.

 This task covers:

a. Testing

b. Removal

c. Installation

INITIAL SETUPMaterials/Parts:

Lock Washer (Clamp)
 1, Appendix G
 Self Locking Nuts (2)
 14, Appendix G
 Tie Down Straps
 24, Appendix E
 Marker Tags (6)
 7, Appendix E
 Silicone RTV
 20, Appendix E
 Tape
 1, Appendix E

Equipment Conditions:

Refrigeration unit shut down (para 2.7) and power disconnected.
 Control box cover door raised and latched.
 Left side panel (evaporator) removed (para 4.13).

General Safety Instructions:**WARNING**

High voltage and exposed rotating parts are used in the refrigeration unit. Personal injury can result if power is connected.

a. Testing. (See Figure 1-4.)

- (1) Be sure power has been disconnected at the source and remove six screws (1).
- (2) Carefully pull circuit breaker cover (2) out to expose thermostat (3) and switch (4) terminals.
- (3) Remove screw (5), lock washer (6), and flat washer (7). Discard lock washer.
- (4) Remove clamp (8).
- (5) Immerse sensing bulb (9) into a temperature controlled bath at 32° F (0° C). A bath at this temperature can be made by putting the sensing bulb into a container of ice and covering with water. Ice must remain packed around sensing bulb at all times during tests.
- (6) Using multimeter set to measure continuity, check thermostat (3) continuity between terminals A1 and A2 with thermostat setting at 24° F (-4° C) and at 40° F (4° C). Continuity should be indicated only when the setting is at 24° F (-4° C). If continuity was indicated at 40° F (4° C) setting, replace thermostat.
- (7) Using multimeter set to measure continuity, check thermostat (3) continuity between terminals B1 and B3 with thermostat setting at 24° F (-4° C) and at 40° F (4° C). Continuity should be indicated only when the setting is at 40° F (4° C). If continuity was indicated at 24° F (-4° C) setting, replace thermostat.
- (8) Remove sensing bulb (9) from temperature controlled bath.
- (9) Adjust thermostat (3) to lowest temperature setting.

4. 23 THERMOSTAT S3 OR SWITCH (HEATER LOCKOUT) S9 TESTING AND REPLACEMENT. Continued

- (10) Using multimeter set to measure continuity, check switch (4) continuity between terminals C and NO with switch button out and pushed in. Continuity should be indicated only when the switch is pushed in. If continuity was indicated when the button was out or no continuity was indicated when the button was pushed in, replace switch.
- (11) Using multimeter set to measure continuity, check switch (4) continuity between terminals C and NO with thermostat setting at 12° F (-11° C) and at 28° F (-2° C). Continuity should be indicated only when the setting is at 28° F (-2° C). If continuity was indicated at 12° F (-11° C) setting, adjust thermostat cam per installation instructions below.
- (12) If no failure was indicated, slip clamp (8) over sensing bulb (9).
- (13) Install clamps (8) and (10), flat washer (7), new lock washer (6), and screw (5).
- (14) Carefully push circuit breaker cover (2) into place and install six screws (1).

b. Removal

- (1) Be sure power has been disconnected at the source and remove six screws (1).
- (2) Carefully pull circuit breaker cover (2) out to expose thermostat (3) and switch (4) terminals.
- (3) Check gasket (11) material for damage. If damaged, notify direct support maintenance to replace it.
- (4) Tag wire leads (12) then remove screws (13) and wire leads.
- (5) Tag and disconnect wire leads (14).
- (6) Remove screw (5), lock washer (6), and flat washer (7). Discard lock washer
- (7) Remove clamp (8).
- (8) Remove tie down straps (15).
- (9) Loosen setscrew (16) and remove knob (17).
- (10) Remove two self locking nuts (18) and bolts (19). Discard self locking nuts.
- (11) Remove remote bulb thermostat (3) and any grommets (20) necessary to remove sensing bulb (9).
- (12) Remove any silicone RTV remaining in evaporator frame grommet (20).
- (13) Loosen setscrew (21) and remove cam (22).
- (14) Squeeze tabs on side of switch (4) and remove.
- (15) If thermostat bracket (23) is damaged, remove two screws (24) and bracket.

c. Installation.

- (1) If removed, install thermostat bracket (23) and two screws (24).
- (2) Install switch (4). Be sure tabs on side of switch snap to secure it in place.
- (3) Install cam (22) but do not tighten setscrew (21) at this time.
- (4) Wrap tape around thermostat (3) capillary tube for a distance of 12 inches (30 cm) from thermostat to protect the capillary tube from electrical components in the control box.
- (5) Install thermostat (3) routing sensing bulb (9) through grommets (20). Install any grommets removed.
- (6) Install two bolts (19) and new self locking nuts (18).
- (7) Slip clamp (8) over sensing bulb (9).
- (8) Install clamps (8) and (10), flat washer (7), new lock washer (6), and screw (5).
- (9) Install tie down straps (15) as necessary.
- (10) Apply silicone RTV into evaporator frame grommet (20) to seal evaporator enclosure.
- (11) Using tags and wiring diagram (fig. 1-4), install wire leads (12) and screws (13). Remove tags.
- (12) Using tags and wiring diagram (fig. 1-4), install wire leads (14). Remove tags.
- (13) Install knob (17) and tighten setscrew (16).
- (14) Adjust and hold thermostat (3) setting to 20° F (-7° C). Using multimeter set to measure continuity, monitor switch (4) continuity between terminals C and NO. Position cam (22) over switch button and rotate cam only clockwise to close the switch contacts, indicated by continuity between terminals. Slowly rotate cam only counterclockwise until the switch contacts just open, indicated by no continuity between terminals. Tighten setscrew (21) at this point.
- (15) Carefully push circuit breaker cover (2) into place and install six screws (1).

NOTE

FOLLOW-ON MAINTENANCE:
Unlatch and close control box cover door.
Install left side panel (evaporator) (para 4.16).
Connect power and put unit back into service.

4.24 FUSES F1 AND F2 TESTING AND REPLACEMENT.

 This task covers:

a. Testing

b. Removal

c. Installation

INITIAL SETUPEquipment Conditions:

Refrigeration unit shut down (para 2.7) and power disconnected.

Control box cover door raised and latched.

Materials/Parts:

Marker Tags (4)
7, Appendix E

General Safety Instructions:**WARNING**

High voltage and exposed rotating parts are used in the refrigeration unit. Personal injury can result if power is connected.

a. Testing

- (1) Be sure power has been disconnected at the source and remove six screws (1). Open control box cover (2).
- (2) Remove two six amp fuses (3).
- (3) Using multimeter set to measure continuity, check each fuse (3) continuity between ends. Continuity should be indicated. If no continuity was indicated, replace fuse.
- (4) If fuse block (4) is damaged, replace it.
- (5) If no failure was indicated, install two fuses (3), close control box cover (2) and install six screws (1).

b. Removal.

- (1) Be sure power has been disconnected at the source and remove six screws (1). Open control box cover (2).
- (2) Remove two fuses (3).

NOTE

Terminal hardware is supplied with fuse block.

- (3) Tag wire lead terminals (5) and remove four screws (6), lock washers (7), and wire lead terminals.
- (4) Remove two screws (8) and fuse block (4).

c. Installation..

- (1) Install fuse block (4) and two screws (8).
- (2) Using tags and wiring diagram (fig. 1-4), install wire lead terminals (5), four lock washers (7), and screws (6). Remove tags.
- (3) Close control box cover (2). Install six screws (1).

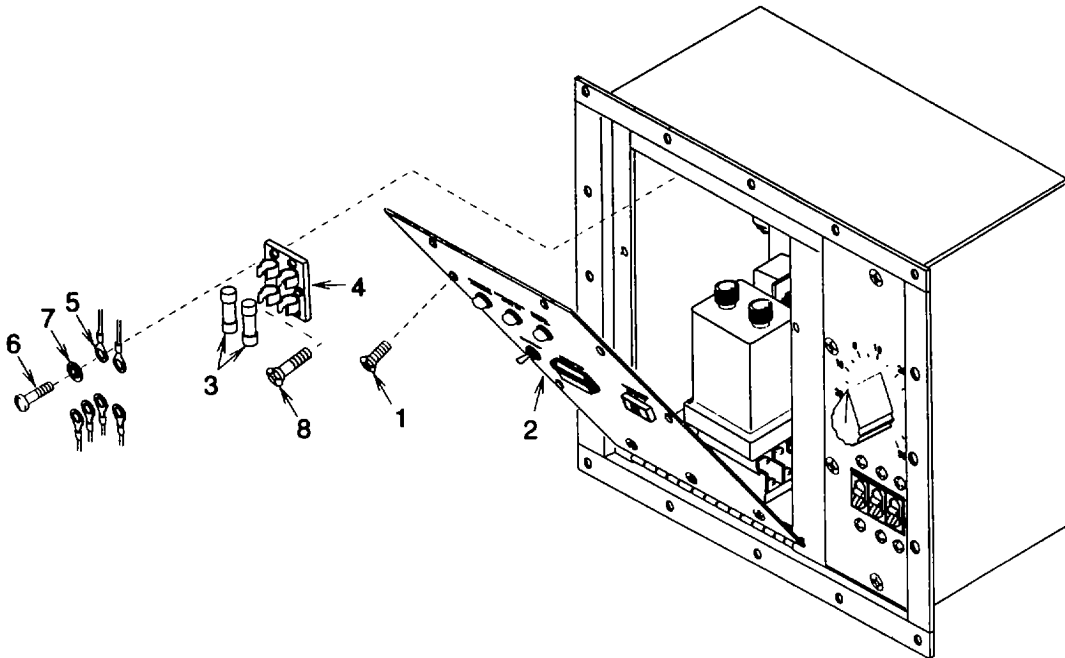

Figure 4-18. Fuses

NOTE

FOLLOW-ON MAINTENANCE:
Unlatch and close control box cover door.
Connect power and put unit back into service.

4.25 MOTOR STARTER K1 TESTING, REPAIR, AND REPLACEMENT.

 This task covers:

a. Testing

b. Removal

c. Installation

INITIAL SETUPMaterials/Parts

Lock Washers (2) (Motor Starter
1, Appendix G
Marker Tags (11)
7, Appendix E

Equipment Conditions:

Refrigeration unit shut down (para 2.7) and power
disconnected.
Control box cover door raised and latched

General Safety Instructions:**WARNING**

**High voltage and exposed rotating parts are
used in the refrigeration unit. Personal injury
can result if power is connected.**

a. Testing. (See Figure 1-4.)

- (1) Be sure power has been disconnected at the source and remove six screws (1). Open control box cover (2).
- (2) Press and hold plunger (3).
- (3) Using multimeter set to measure continuity, check each motor starter (4) contact continuity between terminals L1 to T1, L2 to T2, and L3 to T3. Continuity should be indicated.
- (4) Release plunger (3).
- (5) If no continuity was indicated, test thermal overload heaters (5) per following step.
- (6) Using multimeter set to measure continuity, check each thermal overload heater (5) continuity between mounting screws. Continuity should be indicated. If no continuity was indicated, replace thermal overload heater (5) to repair motor starter (4) and repeat tests.
- (7) Using multimeter set to measure continuity, check coil continuity between terminals A1 to A2. Continuity should be indicated. If no continuity was indicated, replace motor starter (4).
- (8) Press and release RESET button (6).
- (9) Using multimeter set to measure continuity, check overload contacts between terminals 95 to 96. Continuity should be indicated. If no continuity was indicated, replace motor starter (4).
- (10) Using multimeter set to measure continuity, check each motor starter (4) contact continuity between terminals L1 to T1, L2 to T2, and L3 to T3. No continuity should be indicated. If continuity was indicated, replace motor starter.
- (11) If no failure was indicated, close control box cover (2) and install six screws (1).

b. Repair.

- (1) Remove defective thermal overload heater (5).
- (2) Install thermal overload heater (5).

c. Removal.

- (1) Be sure power has been disconnected at the source and remove six screws (1). Open control box cover (2).

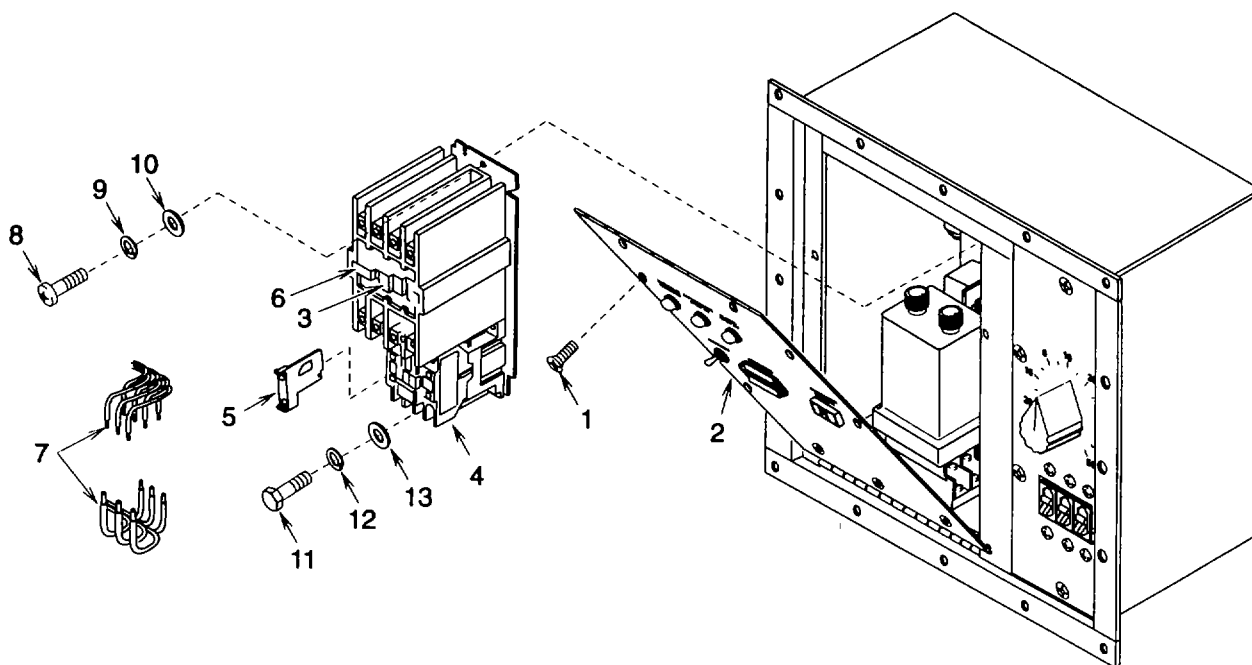

Figure 4-19. Motor Starter (2) Remove defrost timer (para 4.29)

- (3) Tag and disconnect wire leads (7).
- (4) Remove screw (8), lock washer (9), and flat washer (10). Discard lock washer.
- (5) Remove bolt (11), lock washer (12), flat washer (13), and motor starter (4). Discard lock washer.

d. Installation.

- (1) Install three new thermal overload heaters (5) onto new motor starter (4).

NOTE

Steps 2 through 4 apply only to new motor starter. A new motor starter is configured with jumpers connected for operation at 115 Vac and must be reconnected for use with 208/230 Vac.

- (2) Remove two red wire lead jumpers between terminals L2 to 96 and A1 to 3. Discard jumpers.
- (3) Move red wire lead jumper from between terminals A2 to 95 and place between terminals A1 to 95.

4.25 MOTOR STARTER K1 TESTING. REPAIR. AND REPLACEMENT. - Continued

- (4) Set overload adjustment (FLA) dial to A position and (RESET) adjustment dial to M position.
- (5) Install motor starter (4), flat washer (13), new lock washer (12), and bolt (11).
- (6) Install flat washer (10), new lock washer (11), and screw (8).
- (7) Using tags and wiring diagram (fig. 1-4), install wire leads (7). Remove tags.
- (8) Install defrost timer (para 4.29).
- (9) Close control box cover (2). Install six screws (1).

NOTE

FOLLOW-ON MAINTENANCE:
Unlatch and close control box cover door.
Connect power and put unit back into service.

4.26 CONTACTOR (POWER RELAY) K2 TESTING AND REPLACEMENT.

 This task covers:

a. Testing

b. Removal

c. Installation

INITIAL SETUPMaterials/Parts:

Lock Washers (4)
6, Appendix G
Marker Tags (8)
7, Appendix E

Equipment Conditions:

Refrigeration unit shut down (para 2.7) and power disconnected.
Control box cover door raised and latched.

General Safety Instructions**WARNING**

High voltage and exposed rotating parts are used in the refrigeration unit. Personal injury can result if power is connected.

a. Testing. (See Figure 1-4.)

- (1) Be sure power has been disconnected at the source and remove six screws (1). Open control box cover (2)
- (2) Press and hold plunger (3).
- (3) Using multimeter set to measure continuity, check each contactor (4) contact continuity between terminals L1 to T1, L2 to T2, and L3 to T3. Continuity should be indicated.
- (4) Release plunger (3).
- (5) If no continuity was indicated, replace contactor (4).
- (6) Using multimeter set to measure continuity, check coil continuity between terminals A1 to A2. Continuity should be indicated. If no continuity was indicated, replace contactor (4).
- (7) Using multimeter set to measure continuity, check each contactor (4) contact continuity between terminals L1 to T1, L2 to T2, and L3 to T3. No continuity should be indicated. If continuity was indicated, replace contactor.
- (8) If no failure was indicated, close control box cover (2) and install six screws (1).

b. Removal.

- (1) Be sure power has been disconnected at the source and remove six screws (1). Open control box cover (2).
- (2) Tag and disconnect wire leads (5).
- (3) Remove four bolts (6), lock washers (7), flat washers (8), and contactor (4). Discard lock washers.

4.26 CONTACTOR (POWER RELAY) K2 TESTING AND REPLACEMENT. - Continuedc. Installation.

- (1) Install contactor (4), four flat washers (8), new lock washers (7), and bolts (6).
- (2) Using tags and wiring diagram (fig. 1-4), install wire leads (5). Remove tags.
- (3) Close control box cover (2). Install six screws (1).

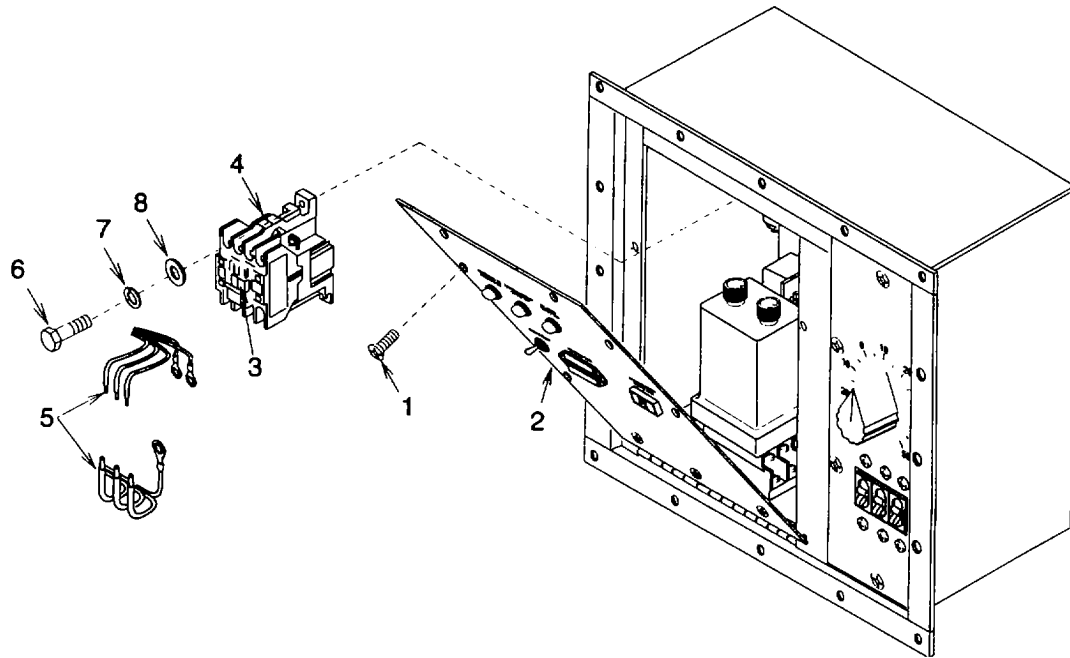
**Figure 4-20. Contactor****NOTE**

FOLLOW-ON MAINTENANCE:
Unlatch and close control box cover door.
Connect power and put unit back into service.

4.27 CONTACTOR (POWER RELAY) K5 TESTING AND REPLACEMENT.

 This task covers:

a. Testing

b. Removal

c. Installation

INITIAL SETUPMaterials/Parts:

Lock Washers (4)
6, Appendix G
Marker Tags (10)
7, Appendix E

Equipment Conditions:

Refrigeration unit shut down (para 2.7) and power disconnected.
Control box cover door raised and latched.

General Safety Instructions**WARNING**

High voltage and exposed rotating parts are used in the refrigeration unit. Personal injury can result if power is connected.

a. Testing. (See Figure 1-4.)

- (1) Be sure power has been disconnected at the source and remove six screws (1). Open control box cover (2).
- (2) Remove defrost timer (para 4.29).
- (3) Press and hold plunger (3) during following tests.
- (4) Using multimeter set to measure continuity, check auxiliary contact (4) continuity between terminals C and NO. Continuity should be indicated. If no continuity was indicated, replace auxiliary contact.
- (5) Using multimeter set to measure continuity, check each contactor (5) contact continuity between terminals L1 to T1, L2 to T2, and L3 to T3. Continuity should be indicated. If no continuity was indicated, replace contactor.
- (6) Release plunger (3).
- (7) Using multimeter set to measure continuity, check coil continuity between terminals A1 to A2. Continuity should be indicated. If no continuity was indicated, replace contactor (5).
- (8) Using multimeter set to measure continuity, check auxiliary contact (4) continuity between terminals C and NO. No continuity should be indicated. If continuity was indicated, replace auxiliary contact.
- (9) Using multimeter set to measure continuity, check each contactor (5) contact continuity between terminals L1 to T1, L2 to T2, and L3 to T3. No continuity should be indicated. If continuity was indicated, replace contactor.
- (10) If no failure was indicated, install defrost timer (para 4.29).
- (11) Close control box cover (2) and install six screws (1).

4.27 CONTACTOR (POWER RELAY) K5 TESTING AND REPLACEMENT. - Continued

b. Removal.

- (1) Be sure power has been disconnected at the source and remove six screws (1). Open control box cover (2).
- (2) Remove defrost timer (para 4.29).
- (3) Tag and disconnect wire leads (6).
- (4) Remove four bolts (7), lock washers (8), flat washers (9), and contactor (5). Discard lock washers.
- (5) Remove auxiliary contact (4).

c. Installation.

- (1) Install auxiliary contact (4).
- (2) Install contactor (5), four flat washers (9), new lock washers (8), and bolts (7).
- (3) Using tags and wiring diagram (fig. 1-4), install wire leads (6). Remove tags.
- (4) Install defrost timer (para 4.29).
- (5) Close control box cover (2). Install six screws (1).

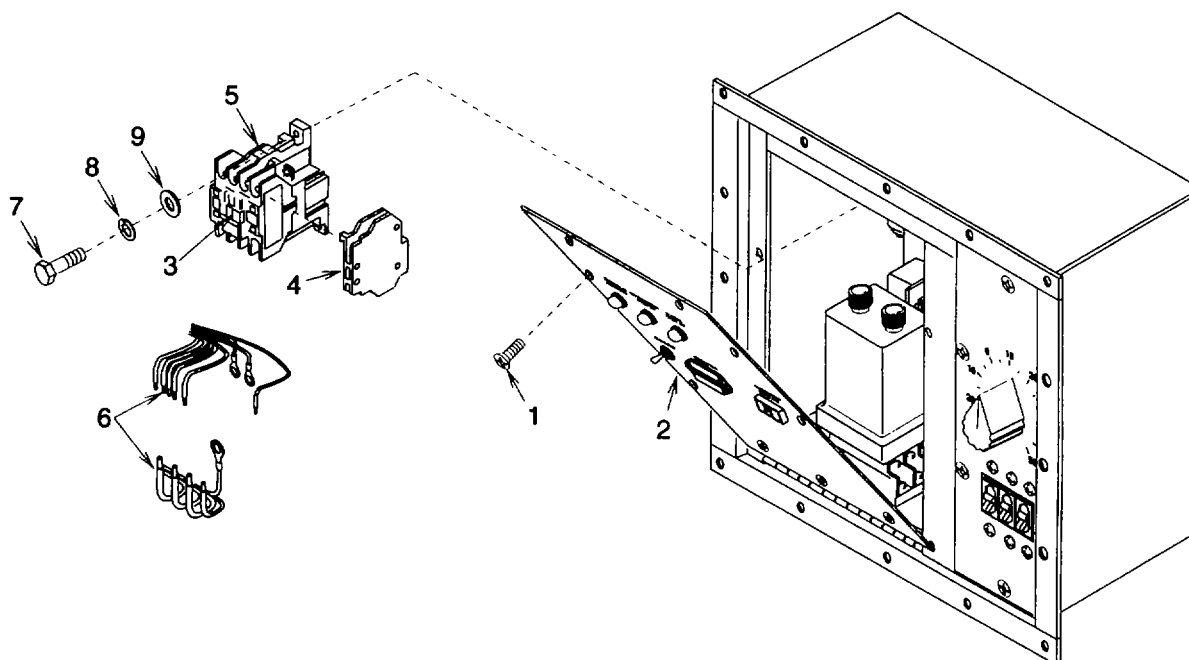

Figure 4-21. Contactor

NOTE

FOLLOW-ON MAINTENANCE:
 Unlatch and close control box cover door.
 Connect power and put unit back into service.

4.28 CONTROL RELAYS K3 AND K4 TESTING AND REPLACEMENT.

This task covers:

a. Testing

b. Removal

c. Installation

INITIAL SETUPTools:

Heat Gun

3, Section III, Appendix B

Equipment Conditions:

Refrigeration unit shut down (para 2.7) and power disconnected.

Control box cover door raised and latched.

Materials/Parts:

Lock Washer (1) (K3)

6, Appendix G

Lock Washer (1) (K4)

6, Appendix G

Sleeving Insulation (3) (K3)

4, Figure F-31, Appendix F

Sleeving Insulation (2) (K4)

4, Figure F-31, Appendix F

Marker Tags (4) (K3)

7, Appendix E

Marker Tags (6) (K3)

7, Appendix E

General Safety Instructions**WARNING**

High voltage and exposed rotating parts are used in the refrigeration unit. Personal injury can result if power is connected.

a. Testing. (See Figure 1-4.)

- (1) Be sure power has been disconnected at the source and remove six screws (1). Open control box cover (2).
- (2) Using multimeter set to measure continuity, check each control relay (3) coil continuity between terminals A to B. Continuity should be indicated. If no continuity was indicated, replace control relay.
- (3) Using multimeter set to measure continuity, check each control relay (3) contact continuity between terminals 7 to 4 (K3 and K4) and 9 to 6 (K4). No continuity should be indicated. If continuity was indicated, replace control relay.
- (4) If no failure was indicated, close control box cover (2) and install six screws (1).

b. Removal.

- (1) Be sure power has been disconnected at the source and remove six screws (1). Open control box cover (2).

NOTE

The following procedures apply to both control relays K3 and K4 Quantities given are for each relay.

- (2) Tag and disconnect wire leads (4). Do not remove sleeving insulation (5) or faston tab adapters (6) unless terminals are damaged.
- (3) Remove bolt (7), lock washer (8), flat washer (9), and control relay (3). Discard lock washer.

4.28 CONTROL RELAYS K3 AND K4 TESTING AND REPLACEMENT. - Continuedc. Installation.**NOTE**

The following procedures apply to both control relays K3 and K4. Quantities given are for each relay:

- (1) Install control relay (3), flat washer (9), new lock washer (8), and bolt (7).
- (2) If wire lead (4) terminals were damaged, repair per paragraph 4.18.
- (3) If sleeving insulation (5) is damaged or was removed, replace it.
 - (a) Using tags and wiring diagram (fig. 1-4), connect wire leads (4) to faston tab adapter (6).
 - (b) Place sleeving insulation (5) over faston tab adapter (6) and wire lead (4) terminals.
 - (c) Shrink sleeving insulation (5) in place using heat gun.
- (4) Using tags and wiring diagram (fig. 1-4), install wire leads (4). Remove tags.
- (5) Close control box cover (2). Install six screws (1).

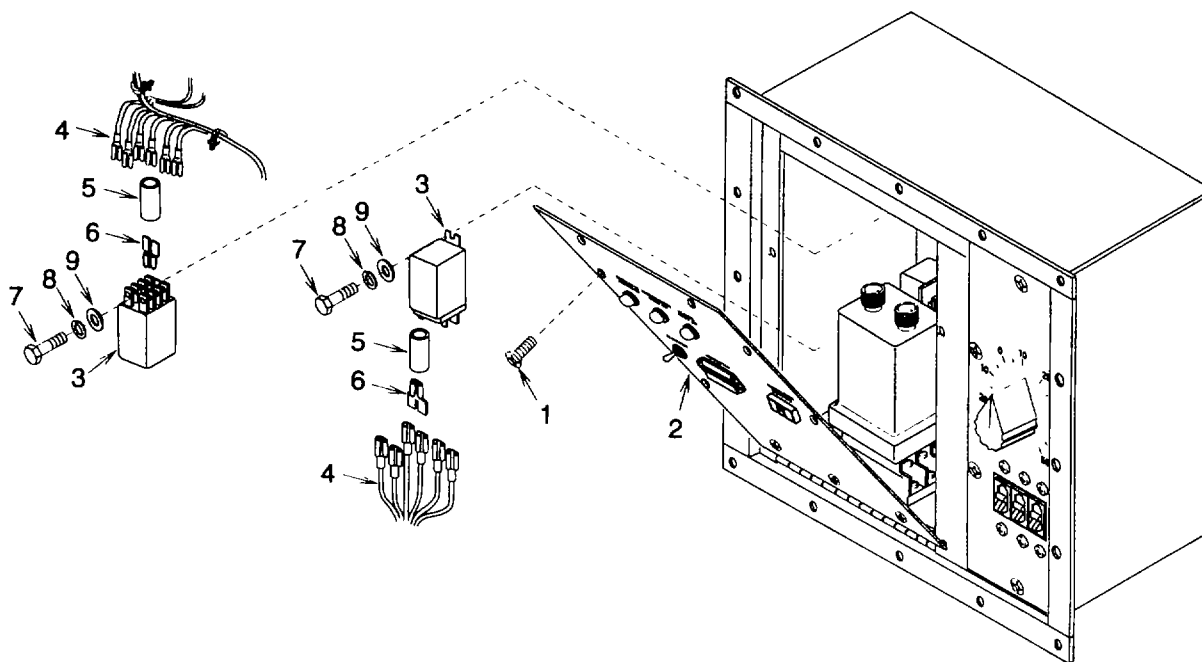

Figure 4-22. Control Relays

NOTE

FOLLOW-ON MAINTENANCE:
 Unlatch and close control box cover door.
 Connect power and put unit back into service.

4.29 DEFROST TIMER TM1 TESTING AND REPLACEMENT.

This task covers:

a. Testing

b. Removal

c. Installation

INITIAL SETUPMaterials/Parts:

Self Locking Nut (2)
8, Appendix G
Tie Down Strap
23, Appendix E
Marker Tags (7)
7, Appendix E

Equipment Conditions:

Refrigeration unit shut down (para 2.7) and power disconnected.
Control box cover door raised and latched.

General Safety Instructions:**WARNING**

High voltage and exposed rotating parts are used in the refrigeration unit. Personal injury can result if power is connected.

a. Testing. (See Figure 1-4.)

- (1) Be sure power has been disconnected at the source and remove six screws (1). Open control box cover (2).
- (2) Remove and discard tie down strap (3).
- (3) Pull defrost timer (4) from relay mounting socket (5).
- (4) Using multimeter set to measure continuity, check defrost timer (4) continuity between terminals 1 to 7. Continuity should be indicated. If no continuity was indicated, replace defrost timer.
- (5) Using multimeter set to measure continuity, check defrost timer (4) continuity between terminals 4 to 7 and 6 to 9. No continuity should be indicated. If continuity was indicated, replace defrost timer.
- (6) If relay mounting socket (5) is damaged, replace it.
- (7) If no failure was indicated, push defrost timer (4) into relay mount socket (5) and install new tie down strap (3).
- (8) Close control box cover (2) and install six screws (1).

b. Removal.

- (1) Be sure power has been disconnected at the source and remove six screws (1). Open control box cover (2).
- (2) Remove and discard tie down strap (3).
- (3) Pull defrost timer (4) from relay mounting socket (5).

4.29 DEFROST TIMER TM1 TESTING AND REPLACEMENT. - Continued

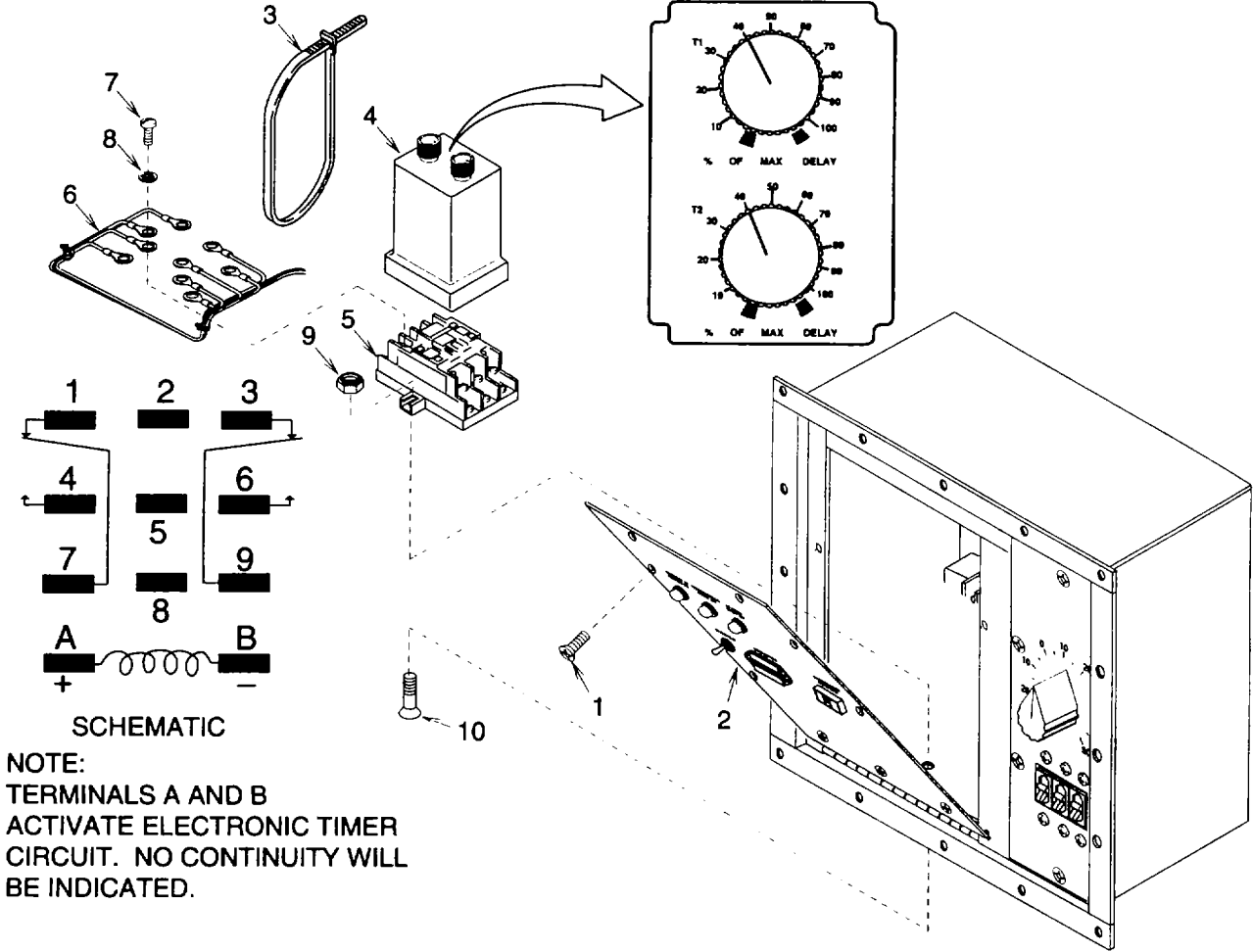

Figure 4-23. Defrost Timer

NOTE

Terminal hardware is supplied with defrost timer.

- (4) Tag wire lead terminals (6) and remove seven screws (7), lock washers (8), and wire lead terminals.
- (5) Remove two self locking nuts (9), screws (10), and relay mounting socket (5). Discard self locking nuts.

c. Installation.

- (1) Install relay mounting socket (5), two screws (10), and new self locking nuts (9).
- (2) Using tags and wiring diagram (fig. 1-4), install wire lead terminals (6), seven lock washers (8), and screws (7). Remove tags.
- (3) Push defrost timer (4) into relay mount socket (5) and install new tie down strap (3).
- (4) Adjust controls (para 4.9) as necessary.
- (5) Close control box cover (2) and install six screws (1).

NOTE

FOLLOW-ON MAINTENANCE:
Unlatch and dose control box cover door.
Connect power and put unit back into service.

4.30 PUSH SWITCHES S6 AND S7 TESTING AND REPLACEMENT.

 This task covers:

a. Testing

b. Removal

c. Installation

INITIAL SETUPTools:

Heat Gun
3, Section III, Appendix B

Materials/Parts:

Self Locking Nuts (2 Each Push Switch)
8, Appendix G
Sleeving Insulation (1 Each Push Switch)
2, Figure F-31, Appendix F
Sleeving Insulation (1 Each Push Switch)
2, Figure F-31, Appendix F
Marker Tags (4)
7, Appendix E

Equipment Conditions:

Refrigeration unit shut down (para 2.7) and power disconnected.
Both side doors open

General Safety Instructions:**WARNING**

High voltage and exposed rotating parts are used in the refrigeration unit. Personal injury can result if power is connected.

a. Testing.

- (1) Remove sleeving insulation (1).
- (2) Tag and disconnect wire leads (2).
- (3) Using multimeter set to measure continuity, check push switch (3) contact continuity across terminals C and NO with the button out and pushed in. Continuity should only be indicated with the button pushed in. If continuity was not indicated when button was pushed in or was indicated with button out, replace push switch.

NOTE

Smaller diameter sleeving insulation must go over wire lead connecting to push switch terminal C.

- (4) If no test indicated a failure, install insulation sleeving (1) over wire leads (2).
- (5) Using tags and wiring diagram (fig. 1-4), connect wire leads (2). Remove tags.

NOTE

Sleeving insulation covers only terminal C on one side of push switch, but must cover both terminals NO and NC on the other side.

- (6) Slip sleeving insulation (1) over exposed terminals and shrink in place using heat gun.

b. Removal.

- (1) Remove sleeving insulation (1).

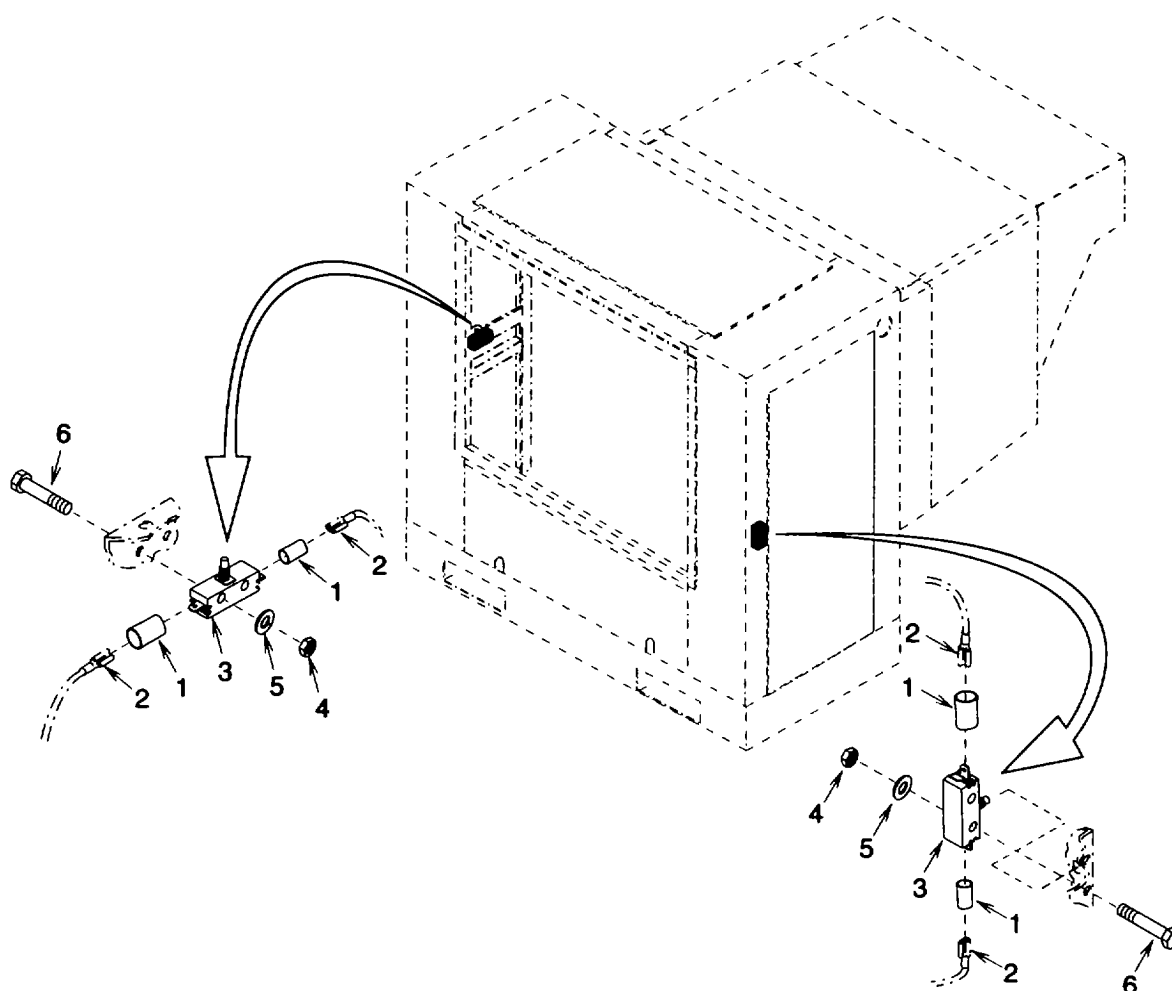

Figure 4-24. Push Switches

(2) Tag and disconnect wire leads (2).

(3) Remove two self locking nuts (4), flat washers (5), bolts (6), and push switch (3). Discard self locking nuts.

c. Installation.

(1) Install push switch (3), two bolts (6), flat washers (5), and new self locking nuts (4).

NOTE

Smaller diameter sleeving insulation must go over wire lead connecting to push switch terminal C.

(2) Install insulation sleeving (1) over wire leads (2).

4.30 PUSH SWITCHES S6 AND S7 TESTING AND REPLACEMENT. - Continued

- (3) Using tags and wiring diagram (fig. 1-4), connect wire leads (2). Remove tags.

NOTE

Sleeving insulation covers only terminal C on one side of push switch, but must cover both terminals NO and NC on the other side.

- (4) Slip sleeving insulation (1) over exposed terminals and shrink in place using heat gun.

NOTE

FOLLOW-ON MAINTENANCE:
Close both side condenser doors.
Connect power and put unit back into service.

4.31 V-BELT REPLACEMENT AND ADJUSTMENT.

This task covers:

- a. INSERT FUNCTION b. INSERT FUNCTION c. INSERT FUNCTION
-

INITIAL SETUPEquipment Conditions:

Refrigeration unit shut down (para 2.7) and power disconnected.
 Left side door open.
 Left side door open.
 Front door open.

General Safety Instructions:**WARNING**

High voltage and exposed rotating parts are used in the refrigeration unit. Personal injury can result if power is connected.

a. Removal.

- (1) Turn self locking nut (1) counterclockwise enough to allow motor mounting plate (2) to be lifted enough to slip V-belt (3) off pulley (4).
- (2) Remove four bolts (5) and flat washers (6).

CAUTION

Moving the fan drive shaft too far can cause damage to the evaporator fan or coil.

- (3) Loosen two set screws (7) and carefully move fan drive shaft (8) just enough to work V-belt (3) around front bearing channel (9) and condenser fan (10).

b. Installation.

- (1) Work V-belt (3) around front bearing channel (9) and condenser fan (10).
- (2) Move fan drive shaft (8) to align front bearing channel (9) mounting holes and install four flat washers (6) and bolts (5). Tighten two set screws (7) against flat surfaces on shaft.
- (3) Slip V-belt (3) over sheave (11) and pulley (4).
- (4) Adjust belt tension.

c. Adjustment.

- (1) Check alignment of pulley (4) and sheave (11). If they are not aligned, loosen set screw (12) and move pulley on AC motor (13) shaft as necessary. When aligned, tighten set screw.
- (2) Turn self locking nut (14) clockwise several turns to allow free travel of motor mount plate (2).
- (3) Turn self locking nut (1) clockwise to increase V-belt (3) tension and counterclockwise to decrease tension. V-belt tension is correct when 4 lb (2 kg) force is applied to the mid point of the V-belt and it deflects 3/8 in. (1 cm). Turn self locking nut (14) clockwise as necessary to allow motor mount plate (2) travel.

4.31 V-BELT REPLACEMENT AND ADJUSTMENT.- Continued

- (4) If the V-belt (3) tension cannot be adjusted within the range of motor mount plate (2) travel, loosen four bolts (15) and slide AC motor (13) on motor mount plate as necessary. Be sure pulley (4) and sheave (11) are aligned and tighten four bolts. Repeat above step to adjust V-belt tension.
- (5) Turn self locking nut (14) counterclockwise against motor mount plate (2).

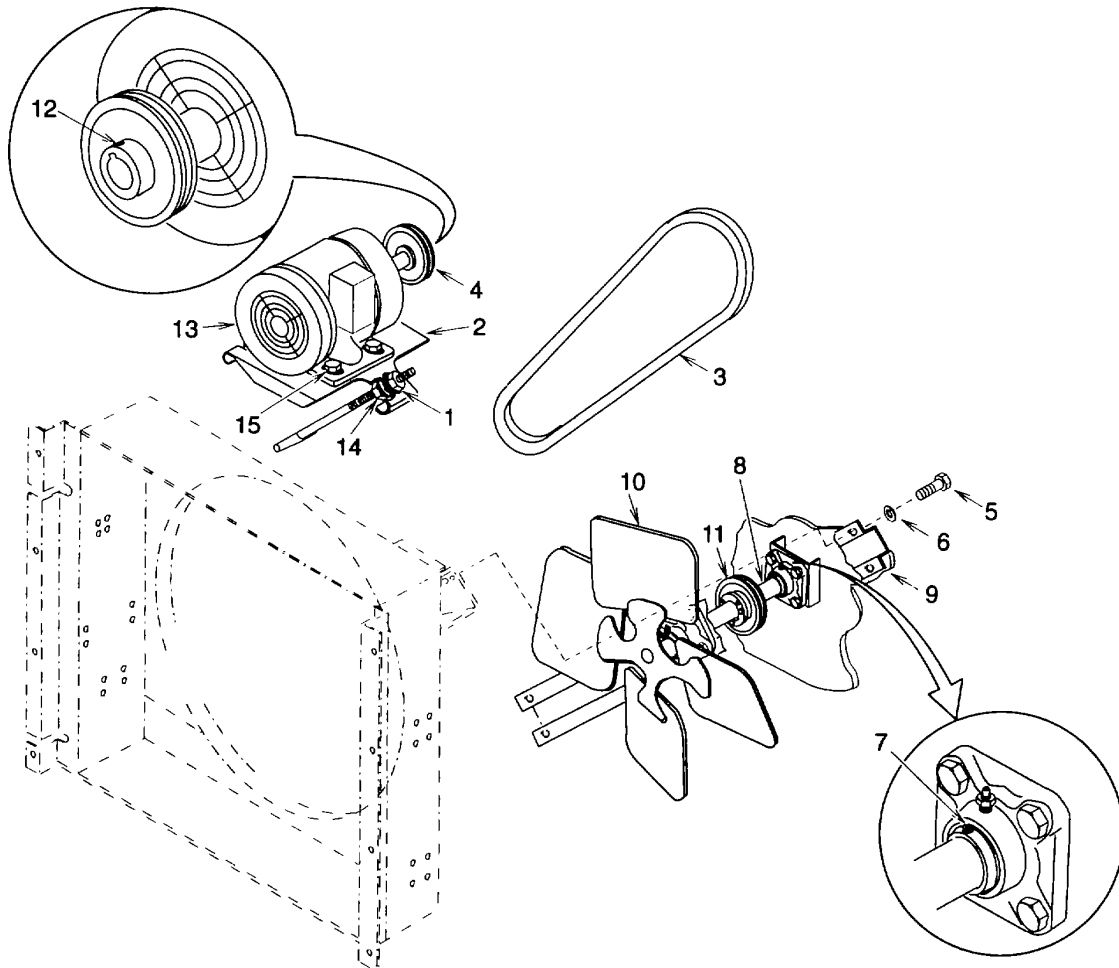

Figure 4-25. V-Belt

NOTE

FOLLOW-ON MAINTENANCE:
 Close left side door.
 Close front door.
 Connect power and put unit back into service.

4-32. PULLEY REPLACEMENT

This task covers:

a. Removal

b. Installation

INITIAL SETUP

Equipment Conditions:

Refrigeration unit shut down (para 2.7) and power disconnected.

V-belt removed from pulley only (para 4.31).

General Safety Instructions:

WARNING

High voltage and exposed rotating parts are used in the refrigeration unit. Personal injury can result if power is connected.

- a. Removal. Loosen set screw (1) and remove pulley (2) from AC motor (3) shaft being careful not to lose key (4).
- b. Installation. Install key (4) then align pulley (2) with key and slide onto AC motor (3) shaft. Tighten set screw (1).

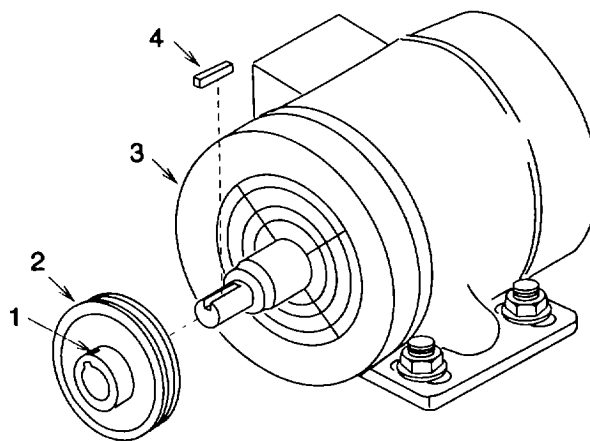

Figure 4-26. Pulley

NOTE

FOLLOW-ON MAINTENANCE:
 Install V-belt onto pulley and adjust (para 4.31).
 Connect power and put unit back into service.

4.33 SHEAVE REPLACEMENT.

This task covers:

- a. Removal b. Installation
-

INITIAL SETUPEquipment Conditions

Refrigeration unit shut down (para 2.7) and power disconnected.

Condenser fan removed (para 4.36).

V-Belt removed(para 4.31).

General Safety Instructions:**WARNING**

High voltage and exposed rotating parts are used in the refrigeration unit. Personal injury can result if power is connected.

a. Removal.

- (1) Remove three bolts (1) and install two bolts back into threaded holes in bushing (2). Tighten bolts evenly to separate bushing from sheave (3). Remove two bolts from bushing.
- (2) Loosen two set screws (4) and remove support (5) and flange bearing (6) from fan drive shaft (7).
- (3) Slide bushing (2) and sheave (3) off fan drive shaft (7) being careful not to lose keys (8) and (9). Remove keys.

b. Installation.

- (1) Install key (9) then slide sheave (3) and bushing (2) onto fan drive shaft (7). Align bushing over key.
- (2) Install key (8) then align sheave (3) with key and slide onto bushing (2).
- (3) Install support (5) and flange bearing (6) onto fan drive shaft (7).
- (4) Install three bolts (1) and tighten evenly to secure sheave (3) to bushing (2).
- (5) Tighten two set screws (4) against flat surfaces on fan drive shaft (7).

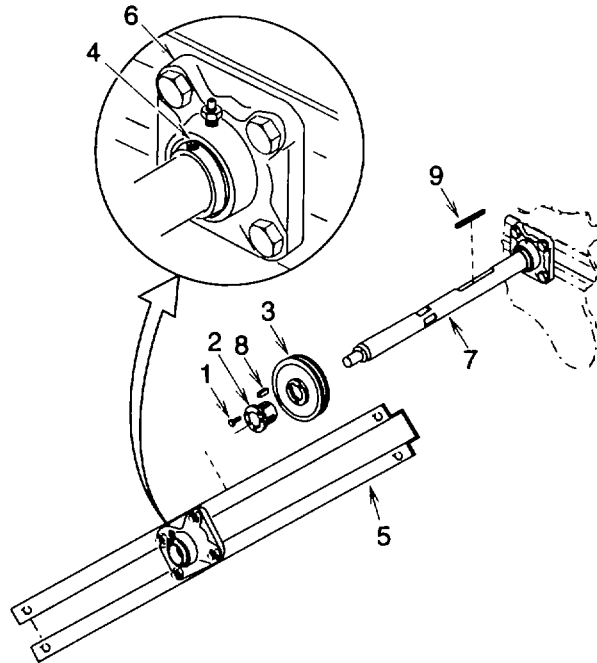

Figure 4-27. Sheave

NOTE

FOLLOW-ON MAINTENANCE:
 Install and adjust V-belt (para 4.31).
 Install condenser fan (para 4.36).
 Connect power and put unit back into service.

4.34 AC MOTOR B2 TESTING AND REPLACEMENT.

 This task covers:

a. Testing

b. Removal

c. Installation

INITIAL SETUPMaterials/Parts:

Lock Washers (4)
7, Appendix G
Self Locking Nuts (2)
17, Appendix G
Marker Tags (7)
7, Appendix E
7, Cotter Pin E2
13, Appendix G

Equipment Conditions:

Refrigeration unit shut down (para 2.7) and power disconnected.
Left side door open.
Front door open.
V-belt removed from pulley only (para 4.31).

General Safety Instructions:**WARNING**

High voltage and exposed rotating parts are used in the refrigeration unit. Personal injury can result if power is connected.

a. Testing. (See Figure 1-4.)

- (1) Remove four bolts (1) and terminal cover (2).
- (2) Tag and disconnect wire leads (3).
- (3) Check that AC motor (4) winding leads are connected as follows; T4 to T14, T5 to T15, T6 to T16, T1 to T7, T2 to T8, and T3 to T9. If the leads are not connected properly, connect them now.
- (4) Using multimeter set to measure continuity, check AC motor (4) winding continuity between leads T1/T7 to T2/T8, T1 /T7 to T3/T9, and T3/T9 to T2/T8. Continuity should be indicated. If continuity was not indicated, replace motor.
- (5) Using multimeter set to measure continuity, check AC motor (4) winding continuity between each lead T1 /T7, T2/T8, and T3/T9 to motor frame ground. No continuity should be indicated. If continuity was indicated, replace motor.
- (6) If no failure was indicated, connect wire leads (2) using tags and wiring diagram (fig. 1-4). Remove tags.
- (7) Install terminal cover (2) and four bolts (1).

b. Removal.

- (1) Remove four bolts (1) and terminal cover (2).
- (2) Tag and disconnect wire leads (3).
- (3) Remove connector locknut (5), connector (6), and wire leads (3).
- (4) Remove four bolts (7), lock washers (8), and AC motor (4) through front door. Discard lock washers.

- (5) Loosen set screw (9) and remove pulley (10) and key (11).
- (6) If motor mount plate (12) must be replaced, remove self locking nut (13), flat washer (14), two cotter pins (15), flat washers (16), motor mount hinge pin (17), motor mount plate, flat washer (18), and self locking nut (19). Discard self locking nuts and cotter pins.

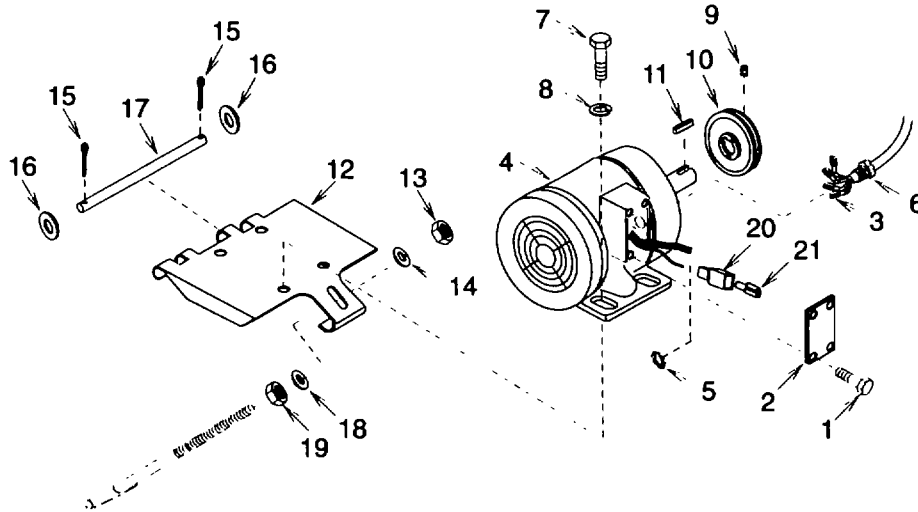

Figure 4-28. AC Motor

c. Installation.

- (1) If motor mount plate (12) was removed, install new self locking nut (19), flat washer (18), motor mount plate, motor mount hinge pin (17), two flat washers (16), new cotter pins (15), flat washer (14), and new self locking nut (13).
- (2) Install one new tab housing (20) and tab (21) onto each pair of new AC motor (4) wire leads T1/T7, T2/T8, and T3/T9 (para 4.18).
- (3) Install key (11) and pulley (10). Tighten set screw (9).
- (4) Install AC motor (4), four new lock washers (8) and bolts (7).
- (5) Install wire leads (3), connector (6), and connector locknut (5).
- (6) Using tags and wiring diagram (fig. 1-4), connect wire leads (3).

4.34 AC MOTOR B2 TESTING AND REPLACEMENT. - Continued

- (7) Install terminal cover (2) and four bolts (1).

NOTE

FOLLOW-ON MAINTENANCE:
Install V-belt onto pulley and adjust (para 4.31).
Close left side door.
Close front door.
Connect power and put unit back into service.

4.35 FLANGE BEARINGS REPLACEMENT.

This task covers:

- a. Removal
- b. Installation

Equipment Conditions:

Refrigeration unit shut down (para 2.7) and power disconnected.
 Sheave removed (para 4.33).

Materials/Parts:

Lock Washers (4)
 16, Appendix G
 Self Locking Nuts (4)
 17, Appendix G

General Safety Instructions:

WARNING

High voltage and exposed rotating parts are used in the refrigeration unit. Personal injury can result if power is connected.

a. Removal.

- (1) Remove four bolts (1), lock washers (2), and flange bearing (3). Discard lock washers.
- (2) Remove four self locking nuts (4), bolts (5), flat washers (6), and flange bearing (7). Discard self locking nuts.

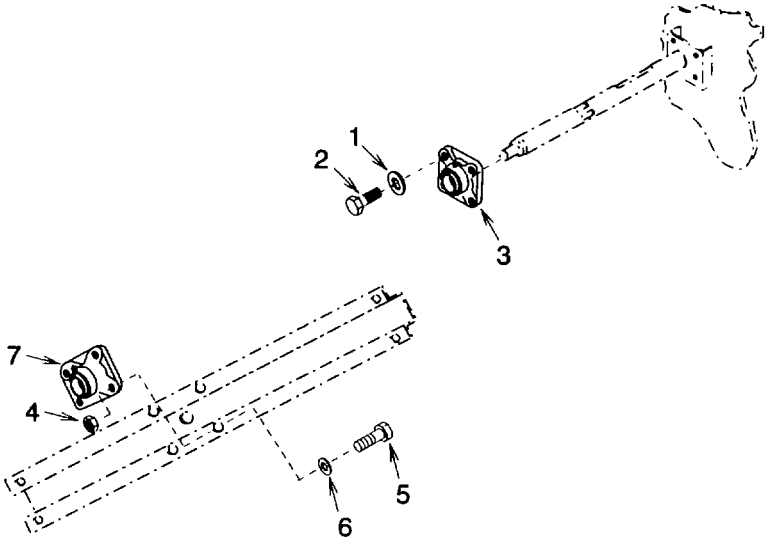

Figure 4-29. Flange Bearings

4.35 FLANGE BEARINGS REPLACEMENT. - Continuedb. Installation.

- (1) Install flange bearing (7), four flat washers (6), bolts (5), and new self locking nuts (4).
- (2) Install flange bearing (3), four new lock washers (2), and bolts (1).

NOTE

FOLLOW-ON MAINTENANCE:
 Install sheave (para 4.33).
 Install and adjust V-belt (para 4.31).
 Install condenser fan (para 4.36).
 Connect power and put unit back into service.

4.36 CONDENSER FAN REPLACEMENT.

This task covers:

a. Removal

c. Installation

Equipment Conditions:

Refrigeration unit shut down (para 2.7) and power disconnected.
 Right side door open.

General Safety Instructions:**WARNING**

High voltage and exposed rotating parts are used in the refrigeration unit. Personal injury can result if power is connected.

a. Removal.

- (1) Loosen two set screws (1).
- (2) Carefully pull condenser fan (2) off fan drive shaft (3), being careful not to lose key (4), and remove from condenser shroud (5).

b. Installation.

- (1) Place condenser fan (2) into condenser shroud (5).
- (2) Align and install condenser fan (2) and key (4) onto fan drive shaft (3).
- (3) Tighten two set screws (1).

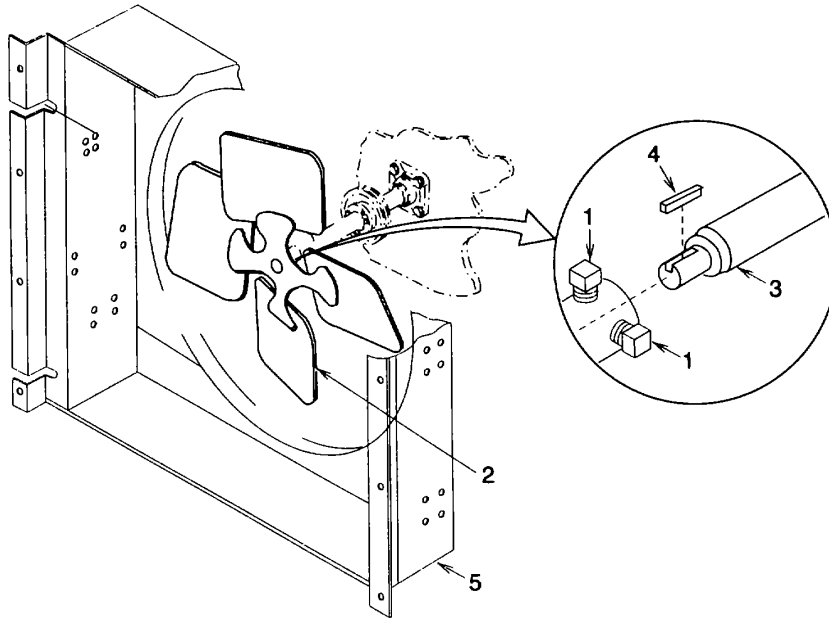

Figure 4-30. Condenser Fan

NOTE

FOLLOW-ON MAINTENANCE:
Close right side door.
Connect power and put unit back into service.

4.37 EVAPORATOR FAN REPLACEMENT.

This task covers:

- a. Removal
- b. Installation

Equipment Conditions:

Refrigeration unit shut down (para 2.7) and power disconnected.
Top panel (evaporator) removed (para 4.15).

General Safety Instructions:

WARNING

High voltage and exposed rotating parts are used in the refrigeration unit. Personal injury can result if power is connected.

a. Removal.

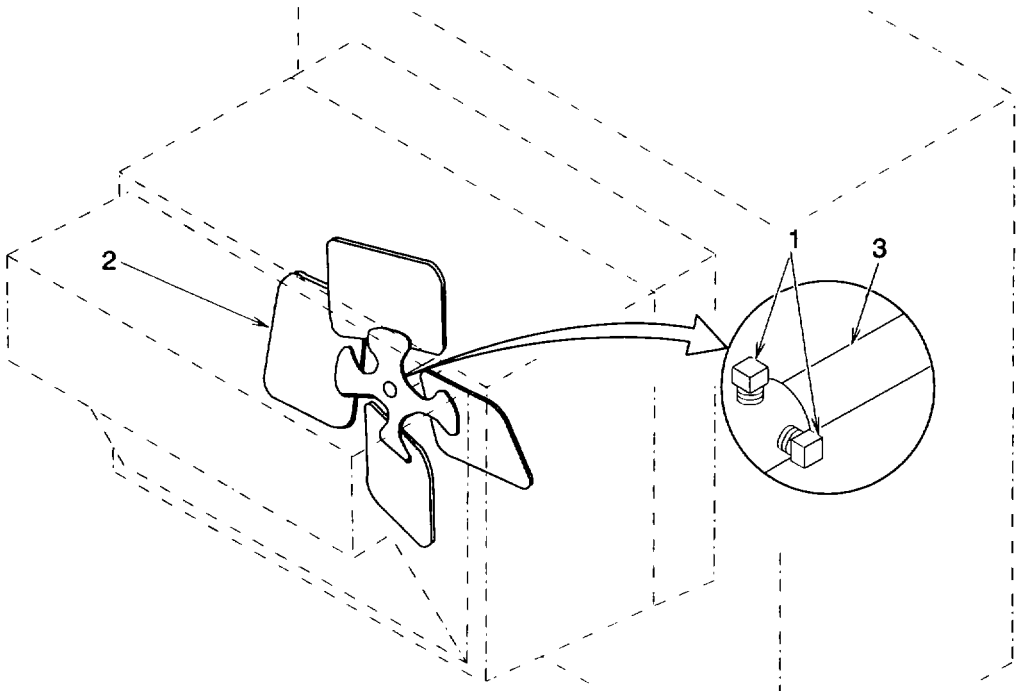

Figure 4-31. Evaporator Fan

- (1) Loosen two set screws (1).
- (2) Carefully pull evaporator fan (2) off fan drive shaft (3) and remove.

b. Installation.

- (1) Install evaporator fan (2) onto fan drive shaft (3).
- (2) Tighten two set screws (1) against flat surfaces on fan drive shaft (3).

NOTE

FOLLOW-ON MAINTENANCE:
Install Top panel (evaporator) (para 4.15).
Connect power and put unit back into service.

4.38 SOLENOID VALVE L1 (LIQUID LINE) TESTING AND REPAIR.

 This task covers:

a. Testing

b. Removal

c. Installation

INITIAL SETUPEquipment Conditions:

Refrigeration unit shut down (para 2.7) and power disconnected.

Left side door open.

Materials/Parts:

Marker Tags (2)
7, Appendix E

General Safety Instructions:**WARNING**

High voltage and exposed rotating parts are used in the refrigeration unit. Personal injury can result if power is connected.

a. Testing.

- (1) Tag and disconnect tabs (1).
- (2) Using multimeter set to measure continuity, check coil (2) continuity between tabs (1). Continuity should be indicated. If no continuity was indicated, replace coil.
- (3) Using multimeter set to measure continuity, check coil (2) continuity between each tab (1) and coil (2) metal case. No continuity should be indicated. If continuity was indicated, replace coil.
- (4) If no failure was indicated, check tabs (1) and tab housing (3). If damaged, repair or replace per paragraph 4.18.
- (5) Using tags and wiring diagram (fig. 1-4), connect tabs (1). Remove tags.

NOTE

The only authorized repair to the solenoid valve is coil replacement. The coil can be replaced without opening the refrigeration pressure system.

b. Removal.**WARNING**

Do not attempt any disassembly of the solenoid valve other than coil removal with a refrigerant charge in the system. Refrigerant will be sprayed out dangerously if the screws that attach the tube and plunger assembly to the valve body are loosened.

- (1) Tag and disconnect tabs (1).

NOTE

Mounting hardware is not supplied with coil. Screw and lock washer must be retained for use during installation of coil.

- (2) Remove screw (4), lock washer (5), data plate (6), and coil (2).
- (3) Cut wire leads (7) if necessary and remove grommet (8).

c. Installation.

- (1) Push wire leads (7) through grommet (8) and install grommet into coil (2).
- (2) Install two tab housings (3) and tabs (1) (para 4.18).
- (3) Install coil (2), data plate (6), lock washer (5), and screw (4).
- (4) Using tags and wiring diagram (fig. 1-4), connect tabs (1). Remove tags.

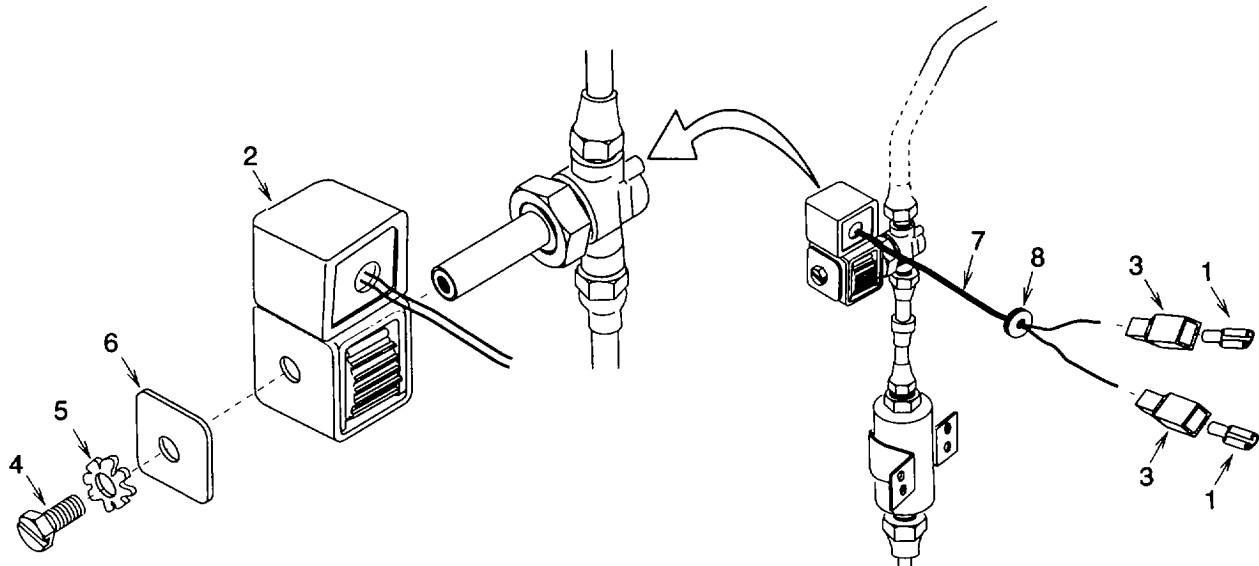

Figure 4-32. Solenoid Valve (Liquid Line)

NOTE

FOLLOW-ON MAINTENANCE:
Close left side door.
Connect power and put unit back into service.

4.39 SOLENOID VALVE L2 (DEFROST LINE) TESTING AND REPAIR.

This task covers:

a. Testing

b. Removal

c. Installation

INITIAL SETUPEquipment Conditions:

Refrigeration unit shut down (para 2.7) and power disconnected.

Right side door open.

Materials/Parts:

Marker Tags (2)
7, Appendix E

General Safety Instructions:**WARNING**

High voltage and exposed rotating parts are used in the refrigeration unit. Personal injury can result if power is connected.

a. Testing.

- (1) Tag and disconnect tabs (1).
- (2) Using multimeter set to measure continuity, check coil (2) continuity between tabs (1). Continuity should be indicated. If no continuity was indicated, replace coil.
- (3) Using multimeter set to measure continuity, check coil (2) continuity between each tab (1) and coil (2) metal case. No continuity should be indicated. If continuity was indicated, replace coil.
- (4) If no failure was indicated, check tabs (1) and tab housing (3). If damaged, repair or replace per paragraph 4.18.
- (5) Using tags and wiring diagram (fig. 1-4), connect tabs (1). Remove tags.

NOTE

The only authorized repair to the solenoid valve is coil replacement. The coil can be replaced without opening the refrigeration pressure system.

b. Removal.**WARNING**

Do not attempt any disassembly of the solenoid valve other than coil removal with a refrigerant charge in the system. Refrigerant will be sprayed out dangerously if the screws that attach the tube and plunger assembly to the valve body are loosened.

- (1) Tag and disconnect tabs (1).

4.39 SOLENOID VALVE L2 (DEFROST LINE) TESTING AND REPAIR. - Continued

This task covers:

- a. Testing
- b. Removal
- c. Installation

NOTE

Mounting hardware is not supplied with coil. Screw and lock washer must be retained for use during installation of coil.

- (2) Remove screw (4), lock washer (5), data plate (6), and coil (2).
- (3) Cut wire leads (7) if necessary and remove grommet (8).

c. Installation.

- (1) Push wire leads (7) through grommet (8) and install grommet into coil (2).
- (2) Install two tab housings (3) and tabs (1) (para 4.18).
- (3) Install coil (2), data plate (6), lock washer (5), and screw (4).
- (4) Using tags and wiring diagram (fig. 1-4), connect tabs (1). Remove tags.

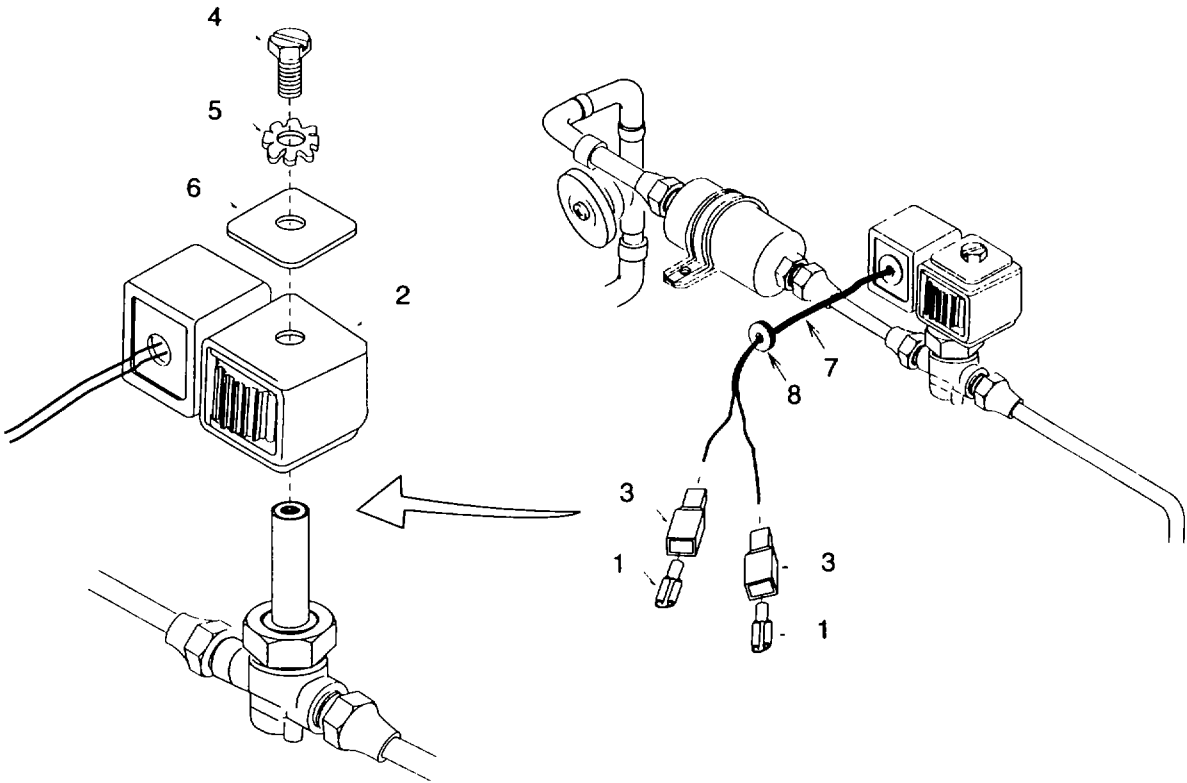

Figure 4-33. Solenoid Valve (Defrost Line)

NOTE

FOLLOW-ON MAINTENANCE:
 Close right side door.
 Connect power and put unit back into service.

4.40 THERMOMETER TESTING AND REPLACEMENT.

 This task covers:

a. Testing

b. Removal

c. Installation

INITIAL SETUPMaterials/Parts:

Lock Washer
1, Appendix G
Lock Washers (3)
6, Appendix G
Tie Down Straps
24, Appendix E

Silicone RTV
20, Appendix E

Equipment Conditions:

Refrigeration unit shut down (para 2.7) and power disconnected.
Left side panel (evaporator) removed (para 4.16).

General Safety Instructions:**WARNING**

High voltage and exposed rotating parts are used in the refrigeration unit. Personal injury can result if power is connected.

a. Testing.

- (1) Remove screw (1), lock washer (2), and flat washer (3). Discard lock washer.
- (2) Remove clamp (4).
- (3) Immerse sensing bulb (5) into a temperature controlled bath at 32° F (0° C). A bath at this temperature can be made by putting the sensing bulb into a container of ice and covering with water. Ice must remain packed around sensing bulb at all times during tests.
- (4) Check temperature indicated on thermometer (6). Temperature indicated should be between 24° F (-4° C) and 40° F (4° C). If temperature indicated is above or below this range, replace thermometer.
- (5) If tests did not indicate a failure, slip clamp (4) over sensing bulb (5).
- (6) Install clamps (4) and (7), flat washer (3), new lock washer (2), and screw (1).

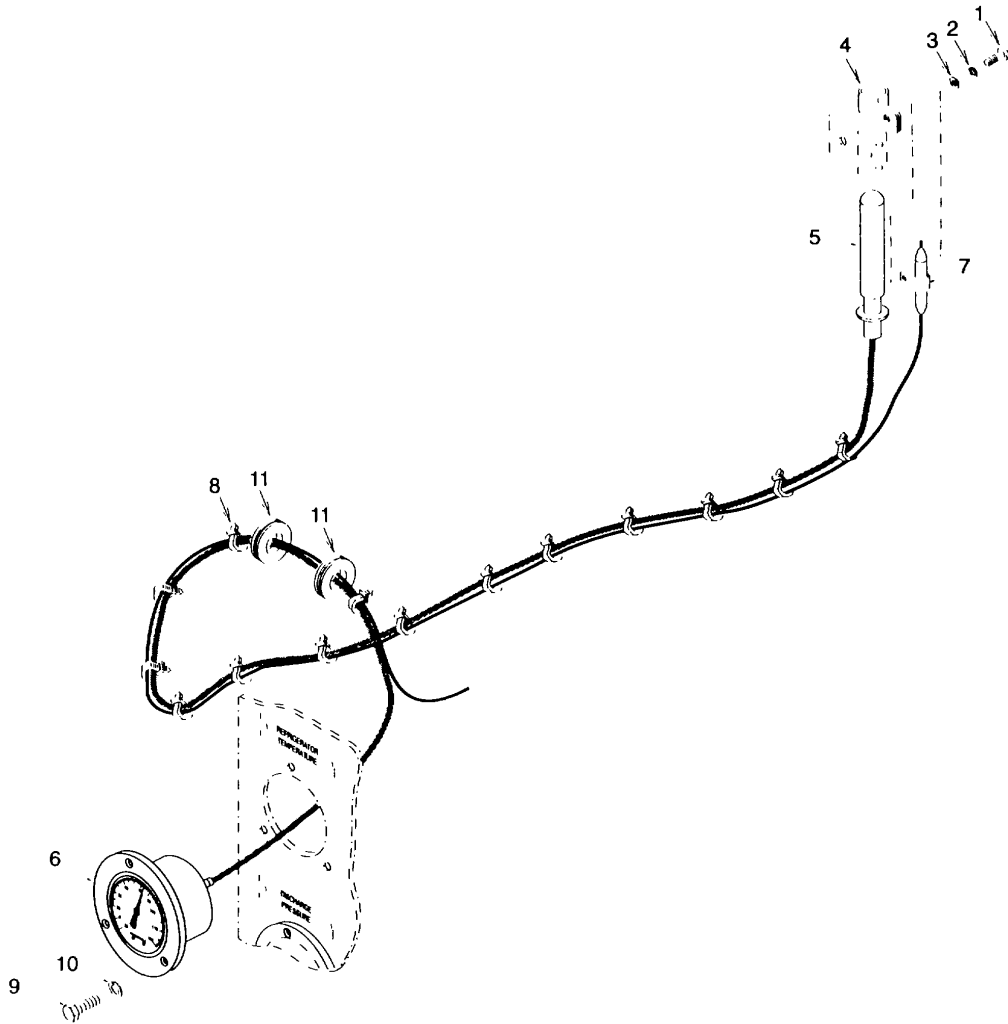

Figure 4-34. Thermometer

4.40 THERMOMETER TESTING AND REPLACEMENT. - Continuedb. Removal.

- (1) Be sure power has been disconnected at the source and open left side door.
- (2) Remove screw (1), lock washer (2), and flat washer (3). Discard lock washer.
- (3) Remove clamp (4).
- (4) Remove tie down straps (8).
- (5) Remove three bolts (9) and lock washers (10). Discard lock washers.
- (6) Remove thermometer (6) and any grommets (11) necessary to remove sensing bulb (5).
- (7) Remove any silicone RTV remaining in evaporator frame grommet (11).

c. Installation.

- (1) Install thermometer (6) routing sensing bulb (5) through grommets (11). Install any grommets removed.
- (2) Install three new lock washers (10) and bolts (9).
- (3) Slip clamp (4) over sensing bulb (5).
- (4) Install clamps (4) and (7), flat washer (3), new lock washer (2), and screw (1).
- (5) Install tie down straps (8) as necessary.
- (6) Apply silicone RTV into evaporator frame grommet (11) to seal evaporator enclosure.
- (7) Close left side door.

NOTE

FOLLOW-ON MAINTENANCE:
Install left side panel (evaporator) (para 4.16).
Connect power and put unit back into service

4.41 ELECTRIC HEATERS HR1. HR2. AND HR3 TESTING AND REPLACEMENT.

 This task covers:

a. Testing

b. Removal

c. Installation

INITIAL SETUPMaterials/Parts:

Self Locking Nuts (12)
 Appendix G
 Self Locking Nuts (4)

8, Appendix G
 Marker Tags (6)
 7, Appendix E

Equipment Conditions:

Refrigeration unit shut down (para 2.7) and power 14,
 disconnected.

General Safety Instructions:**WARNING**

High voltage and exposed rotating parts are
 used in the refrigeration unit. Personal injury
 can result if power is connected.

a. Testing. Be sure power has been disconnected at the source and using multimeter set to measure continuity, check each electric heater (1) continuity between terminal ends A and B. Continuity should be indicated. If no continuity was indicated, replace electric heater.

b. Removal.

- (1) Be sure power has been disconnected at the source and remove 12 self locking nuts (2), flat washers (3), bolts (4), and flat washers (5). Discard self locking nuts.
- (2) Carefully remove heater frame (6) as far as wire leads (7) will reach.
- (3) Tag and disconnect wire leads (7).
- (4) Remove four self locking nuts (8), flat washers (9), bolts (10), flat washers (11), and heater keeper plate (12). Discard self locking nuts.
- (5) Remove three electric heaters (1).

c. Installation.

- (1) Install three electric heaters (1).
- (2) Install heater keeper plate (12), four flat washers (11), bolts (10), flat washers (9), and new self locking nuts (8).
- (3) Using tags and wiring diagram (fig. 1-4), install wire leads (7). Remove tags.
- (4) Install heater frame (6) and align mounting holes.
- (5) Install 12 flat washers (5), bolts (4), flat washers (3), and new self locking nuts (2).

4.41 ELECTRIC HEATERS HR1, HR2, AND HR3 TESTING AND REPLACEMENT.- Continued

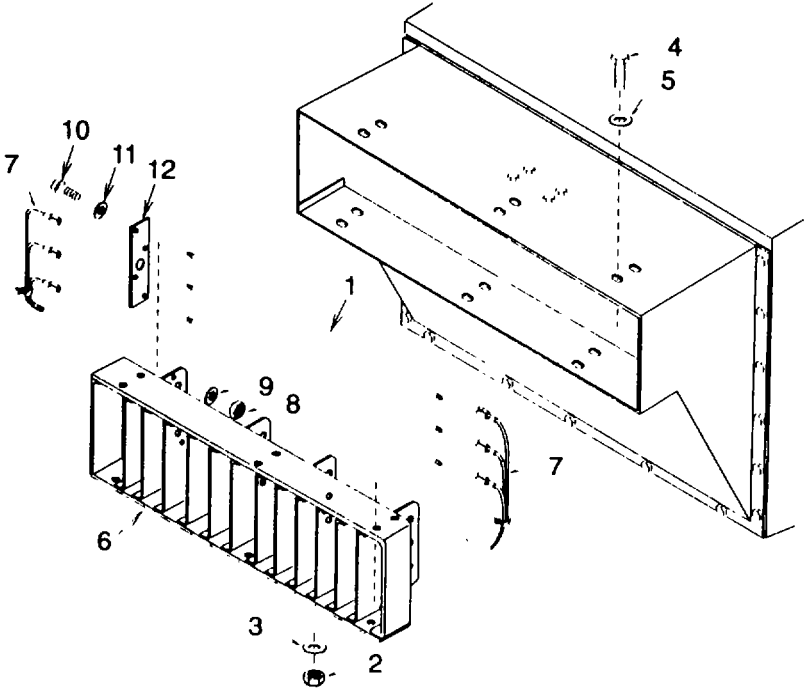

Figure 4-35. Electric Heaters

NOTE

FOLLOW-ON MAINTENANCE:
Connect power and put unit back into service.

4.42 THERMOSTATIC SWITCH S8 TESTING AND REPLACEMENT.

 This task covers:

a. Testing

b. Removal

c. Installation

INITIAL SETUPTools:

Heat Gun
3, Section III, Appendix B

Equipment Conditions:

Refrigeration unit shut down (para 2.7) and power disconnected.

Materials/Parts:

Self Locking Nuts (4) (Heater Frame)
14, Appendix C
Self Locking Nuts (4) (Bracket)
14, Appendix G
Self Locking Nuts (2) (Thermostatic Switch)
14, Appendix G
14, Appendix G
Marker Tags (9)
7, Appendix E

General Safety Instructions:**WARNING**

High voltage and exposed rotating parts are used in the refrigeration unit. Personal injury can result if power is connected.

a. Testing.

- (1) Be sure power has been disconnected at the source and remove 12 self locking nuts (1), flat washers (2), bolts (3), and flat washers (4). Discard self locking nuts.
- (2) Carefully remove heater frame (5) as far as wire leads (6) will reach.
- (3) Tag and disconnect wire leads (6) and set heater frame (5) aside.
- (4) Remove four self locking nuts (7), flat washers (8), bolts (9), flat washers (10), and bracket (11) as far as wire leads (12) will reach. Discard self locking nuts.
- (5) Using multimeter set to measure continuity, check thermostatic switch (13) continuity between terminals 4 to 5, 5 to 6, and 6 to 4. Continuity should be indicated. If no continuity was indicated, replace thermostatic switch.
- (6) Heat thermostatic switch (13) sensor surface plate to a temperature of 203° F (95° C) using heat gun then using multimeter set to measure continuity, check thermostatic switch continuity between terminals 4 to 5, 5 to 6, and 6 to 4. Continuity should not be indicated. If continuity was indicated, replace thermostatic switch.
- (7) Remove heat from thermostatic switch (13).
- (8) If no test indicated a failure, install bracket (11), four flat washers (10), bolts (9), flat washers (8), and new self locking nuts (7).

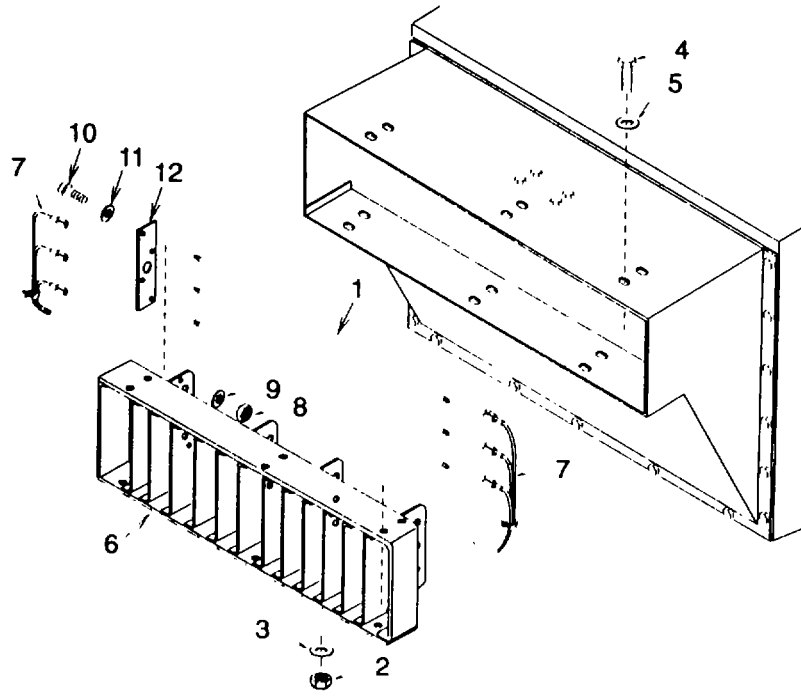

Figure 4-36. Thermostatic Switch

b. Removal.

- (1) Be sure power has been disconnected at the source and remove 12 self locking nuts (1), flat washers (2), bolts (3), and flat washers (4). Discard self locking nuts.
- (2) Carefully remove heater frame (5) as far as wire leads (6) will reach.
- (3) Tag and disconnect wire leads (6) and set heater frame (5) aside.
- (4) Remove four self locking nuts (7), flat washers (8), bolts (9), flat washers (10), and bracket (11) as far as wire leads (12) will reach. Discard self locking nuts.
- (5) Remove two self locking nuts (14), flat washers (15), bolts (16), and bracket (11).
- (6) Tag and disconnect wire leads (12) (para 4.18).

c. Installation.

- (1) Using tags and wiring diagram (fig. 1-4), install wire leads (12) (para 4.18). Remove tags.
- (2) Install bracket (11), two bolts (16), flat washers (15), and new self locking nuts (14).
- (3) Install bracket (11), four flat washers (10), bolts (9), flat washers (8), and new self locking nuts (7).
- (4) Using tags and wiring diagram (fig. 1-4), install wire leads (6). Remove tags.
- (5) Install heater frame (5) and align mounting holes.
- (6) Install 12 flat washers (4), bolts (3), flat washers (2), and new self locking nuts (1).

NOTE

FOLLOW-ON MAINTENANCE:
Connect power and put unit back into service.

4.43 TEMPERATURE SWITCH S4 REPLACEMENT.

This task covers:

- a. Removal b. Installation
-

INITIAL SETUPEquipment Conditions:

Refrigeration unit shut down (para 2.7) and power disconnected.
 Right side panel (evaporator) removed (para 4.16).

Materials/Parts:

Marker tags (2)
 7, Appendix E
 Insulation Tape
 10, Appendix E
 Tie Down Straps (2)
 24, Appendix E

General Safety Instructions:**WARNING**

High voltage and exposed rotating parts are used in the refrigeration unit. Personal injury can result if power is connected.

a. Removal.

- (1) Remove insulation (1) as necessary.
- (2) Be sure power has been disconnected at the source then tag and disconnect two tabs (2).
- (3) Remove two tie down straps (3) and temperature switch (4).

b. Installation.

- (1) Install temperature switch (4), and two new tie down straps (3).
- (2) Install new tab housing (5) and tab (2) onto each temperature switch (4) wire lead (para 4.18).
- (3) Using tags and wiring diagram (fig. 1-4), connect tabs (2). Remove tags.
- (4) Install insulation (1) and secure with insulation tape as necessary.

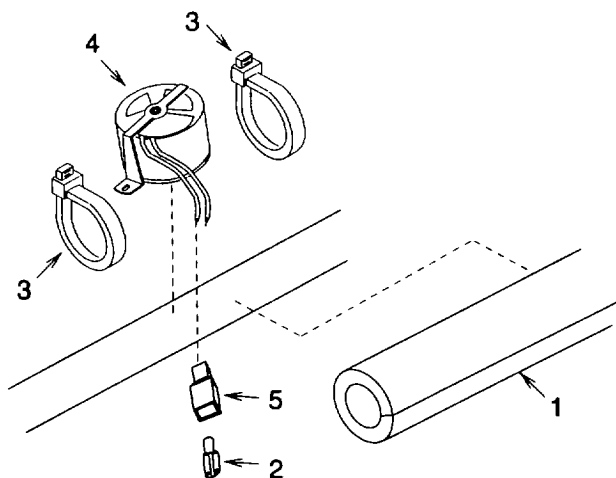

Figure 4-37. Temperature Switch

NOTE

FOLLOW-ON MAINTENANCE:
 Install right side panel (evaporator) (para 4.16).
 Connect power and put unit back into service.

4.44 GASKET REPLACEMENT.

 This task covers:

a. Removal

b. Installation

INITIAL SETUPEquipment Conditions:

Refrigeration unit shut down (para 2.7) and power disconnected.

Refrigeration unit removed from refrigerator enclosure (para 4.7).

Materials/Parts:

Silicone RTV

20, Appendix E

Gasket

Figure F-8, Appendix F

Gasket

Figure F-9, Appendix F

Gasket

Figure F-10, Appendix F

Gasket

Figure F-11, Appendix F

a. Removal.**NOTE**

Remove only the individual gasket pieces that need to be replaced.

- (1) Remove nine screws (1), one each gasket retainer strips (2) and (3), and top outside gasket (4). Repeat for bottom outside gasket (5).
- (2) Remove eight screws (6), two gasket retainer strips (7), and top inside gasket (8). Repeat for bottom inside gasket (9).
- (3) Remove seven screws (10), one each gasket retainer strips (11) and (12), and left outside gasket (13). Repeat for right outside gasket (14).
- (4) Remove six screws (15), one each gasket retainer strips (16) and (17), and left inside gasket (18). Repeat for right inside gasket (19).
- (5) Remove any silicone RTV remaining on gasket(s).

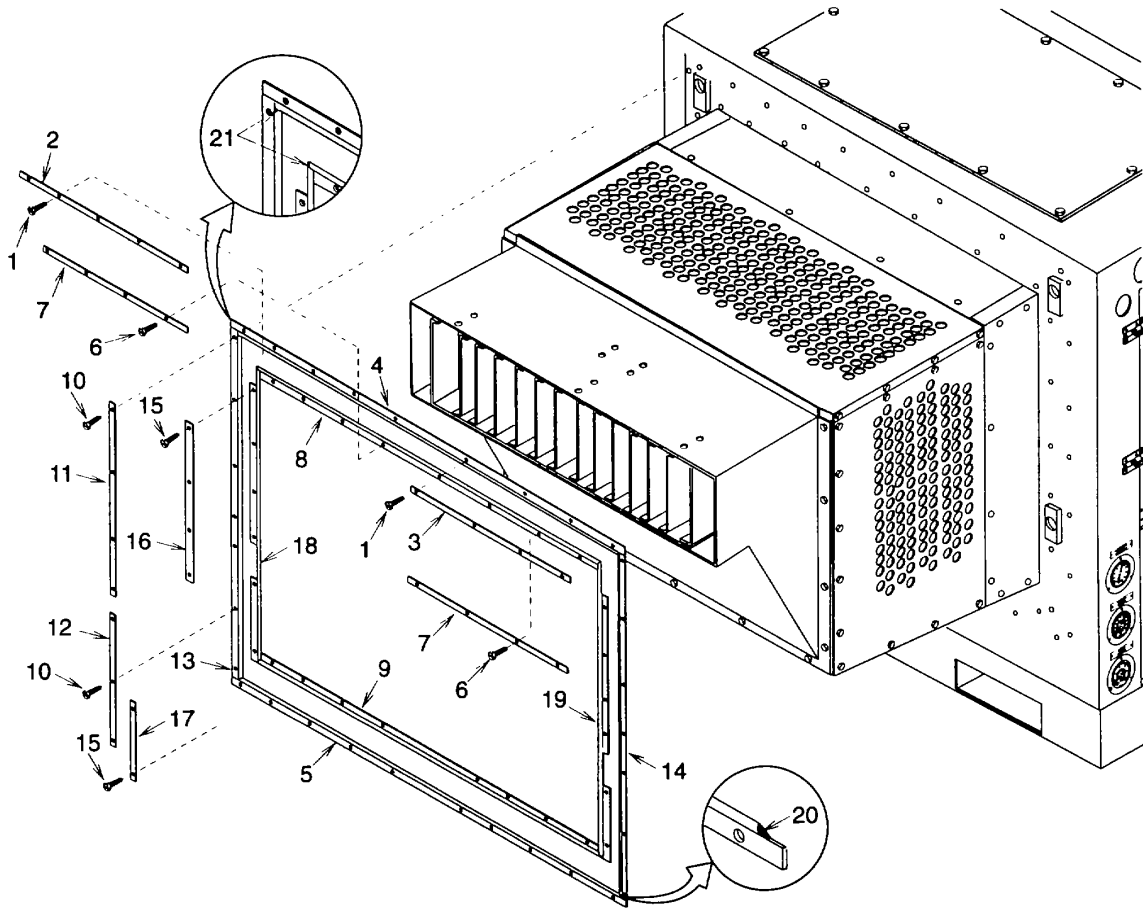

Figure 4-38. Gasket

b. Installation.

- (1) Fabricate the required gasket(s) (appendix F).
- (2) Seal the cut surface(s) (20) of gasket(s) with silicone RTV.
- (3) Install left inside gasket (18), one each gasket retainer strips (16) and (17), and six screws (15). Repeat for right inside gasket (19).
- (4) Install left outside gasket (13), one each gasket retainer strips (11) and (12), and seven screws (10). Repeat for right outside gasket (14).
- (5) Install top inside gasket (8), two gasket retainer strips (7), and eight screws (6). Repeat for bottom inside gasket (9).
- (6) Install top outside gasket (4), one each gasket retainer strips (2) and (3), and nine screws (1). Repeat for bottom outside gasket (5).
- (7) Seal the seam(s) (21) of gasket(s) with silicone RTV.

NOTE**FOLLOW-ON MAINTENANCE:**

Install refrigeration unit onto refrigerator enclosure (para 4.7).
Connect power and put unit back into service.

4.45 BARREL BOLTS REPLACEMENT.

 This task covers:

- a. Removal b. Installation
-

INITIAL SETUPEquipment Conditions:

Refrigeration unit shut down (para 2.7) and power disconnected.

Materials/Parts:

Lock, Washer (6)
1, Appendix G

General Safety Instructions:**WARNING**

High voltage and exposed rotating parts are used in the refrigeration unit. Personal injury can result if power is connected.

a. Removal.

- (1) Remove four bolts (1), lock washers (2), and barrel bolt (3). Discard lock washers.
- (2) Remove two bolts (4), lock washers (5), and barrel bolt clip (6). Discard lock washers.

b. Installation.

- (1) Install barrel bolt clip (6), two new lock washers (5), and bolts (4).
- (2) Install barrel bolt (3), four new lock washers (2), and bolts (1).

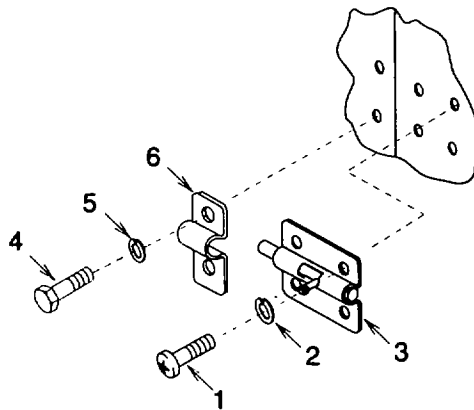

Figure 4-39. Barrel Bolts

NOTE

FOLLOW-ON MAINTENANCE:
Connect power and put unit back into service.

SECTION VII PREPARATION FOR STORAGE OR SHIPMENT.**4.46 ADMINISTRATIVE STORAGE.**

Placement of equipment in administrative storage should be for short periods of time (1 to 45 days) when a shortage of maintenance effort exists. Items should be in mission readiness within 24 hours or within the time factors as determined by the directing authority. During the storage period, appropriate maintenance records will be kept.

4.46.1 Before placing the equipment in administrative storage, current preventive maintenance checks and services should be completed, shortcomings and deficiencies should be corrected, and all Modification Work Orders (MWO) should be applied.

4.46.2 Storage site selection. Inside storage is preferred for items selected for administrative storage. If inside storage is not available, trucks, vans, conex containers, and other containers may be used.

4.47 PUMP DOWN REFRIGERATION UNIT.**WARNING**

High voltage and exposed rotating parts are contained in the refrigeration unit. Personal injury can result if power is connected.

- a. Be sure refrigeration unit is shut down and power is disconnected then remove two isolation valve caps (1) and shut off valve caps (2).
- b. Close hot gas stop valve (3).
- c. Close receiver outlet valve (4).
- d. Be sure the condenser side doors are closed and operate the refrigeration unit (para 2.5) until it shuts down automatically.
- e. Shut down the refrigeration unit (para 2.7) and disconnect power.
- f. Close receiver inlet valve (5), compressor shut off valves (6), and liquid stop valve (7).
- g. Install two shut off valve caps (2) and isolation valve caps (1).
- h. Place a marker tag (7, appendix E) on or near the control box cover stating "THE REFRIGERATION UNIT HAS BEEN PUMPED DOWN, DO NOT OPERATE UNTIL ALL VALVES HAVE BEEN PROPERLY SET, EQUIPMENT DAMAGE WILL OCCUR."

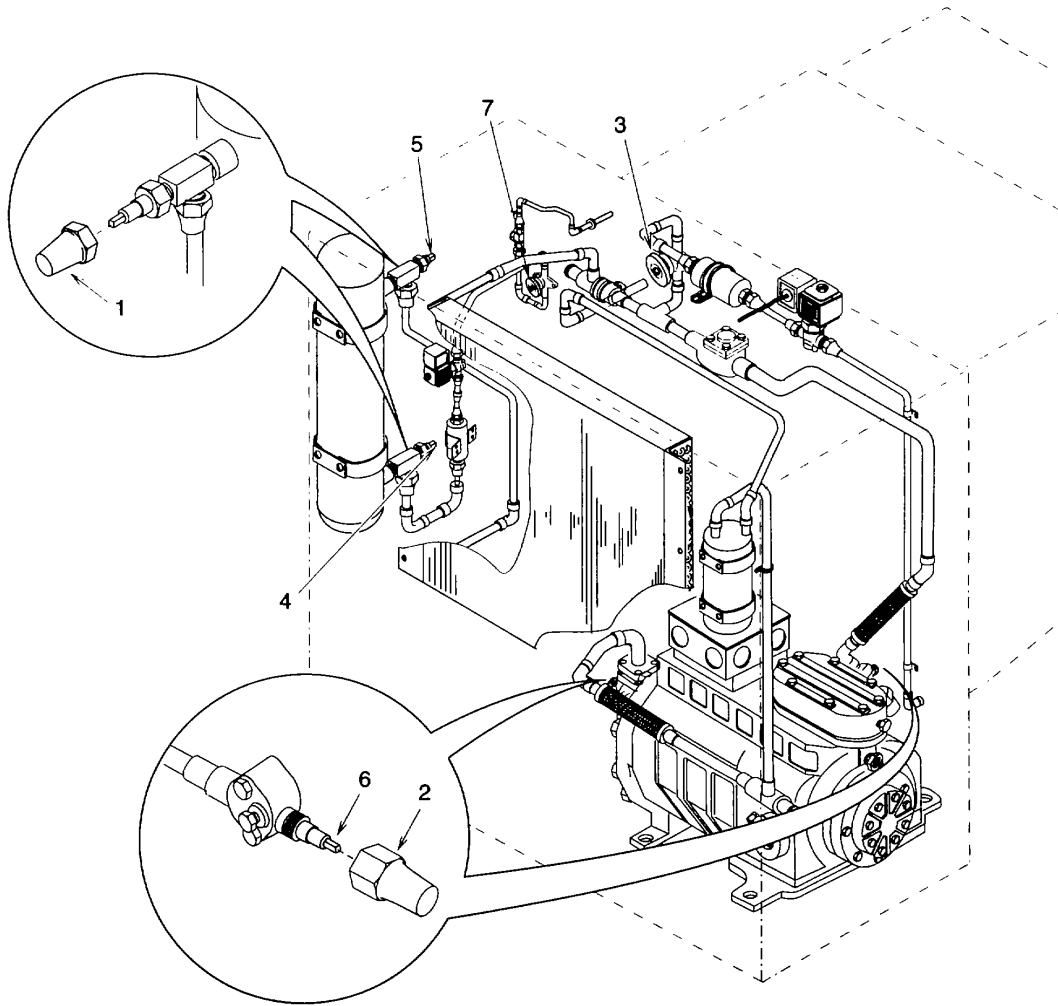

Figure 4-40. Refrigeration System Pump Down

4.48 LONG TERM STORAGE OR SHIPMENT.

Placement of equipment in long term storage should be for extended periods of time (45 days or more). Before placing the equipment in long term storage, current preventive maintenance checks and services should be completed, shortcomings and deficiencies should be corrected, and all Modification Work Orders (MWO) should be applied.

- a. Open both side condenser doors and both front bottom doors.
- b. Tighten four compressor mount locknuts (1, fig. 4-41) just to the point where the compressor bottoms against the rubber pads underneath it.

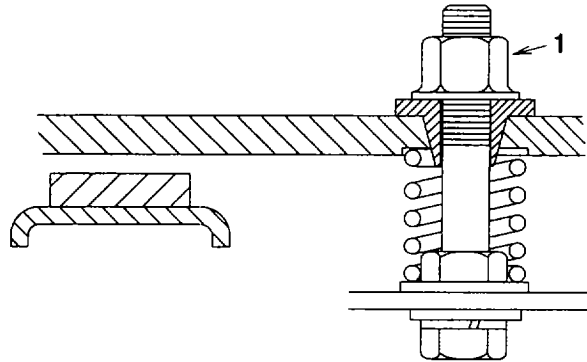

Figure 4-41. Compressor Mount

- c. Close both side condenser doors and both front bottom doors.

NOTE

Refrigerant and oil will not be removed from the system.

- d. Preserve the refrigeration unit in accordance with MIL-P-116, method I.
 - (1) Cover all openings into the electric motor, evaporator panel, glass gauges, name plates and instruction panels, switches, control boxes, etc., with waterproof paper and seal with tape conforming to PPP-T-60, or with a barrier material conforming to grade A of MIL-B-121 and secured in place.
 - (2) Package the refrigeration unit in accordance with ASTM D 3951, level A or Commercial.
 - (3) Refrigeration unit shall be packed upright in an open crate or cleated plywood box conforming to type V, style A of MIL-C-52950 or style B for overseas. Each unit shall be secured and the container closed and strapped with 3/4 inch by 0.023 inch steel. The strapping shall be applied over the horizontal top, bottom, and intermediate cleats of the side and ends.
 - (4) Shipping containers shall be marked with the words "UP" and "THIS SIDE DOWN" shall appear on each shipping container.

CHAPTER 5

DIRECT SUPPORT MAINTENANCE INSTRUCTIONS

SECTION I DIRECT SUPPORT TROUBLESHOOTING INSTRUCTIONS

5.1 TROUBLESHOOTING.

The following procedures are listed in order of the most probable malfunctions. Each malfunction is followed by test or inspection procedures in logical order to isolate and identify the fault and actions required to correct it. This section cannot list all the possible malfunctions that may occur with the equipment. If a malfunction occurs that is not listed or action listed do not correct a malfunction, notify your supervisor.

a. Pressure Gauge (High) Indicates Above Operating Range.

INSTALL SERVICE MANIFOLD (PARA 5.7) AND OPERATE REFRIGERATION UNIT (PARA 2.5). DOES SERVICE MANIFOLD GAUGE READING MATCH PRESSURE GAUGE (HIGH) READING ?

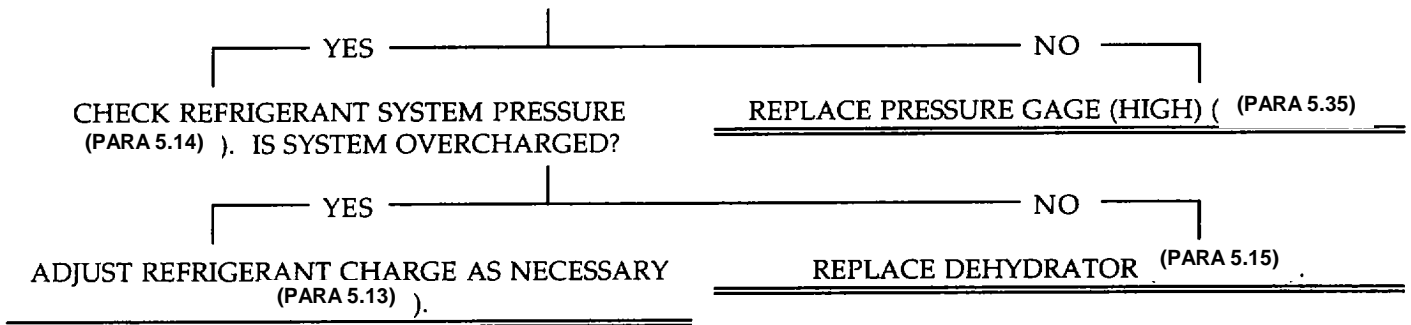

b. Compressor Operates For Short Period Then Stops.

OPERATE REFRIGERATION UNIT (PARA 2.5) AND OBSERVE PRESSURE GAUGE (LOW). DOES PRESSURE DROP RAPIDLY ?

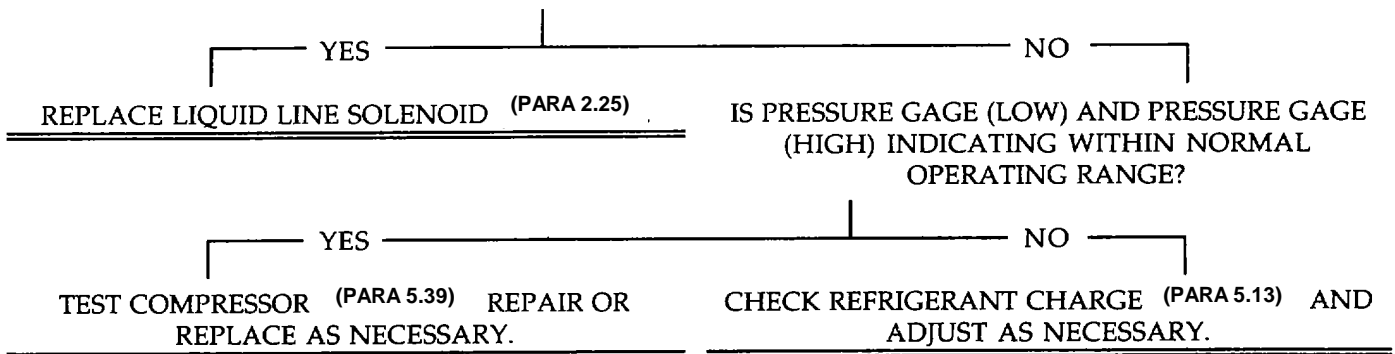

c. Pressure Readings Low/Insufficient Cooling.

SHUT DOWN REFRIGERATION UNIT (PARA 2.7).
 DOES THE REFRIGERATION UNIT STOP RUNNING ?

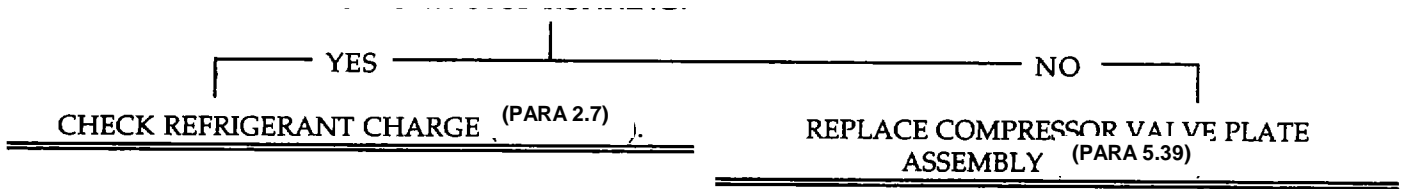

SECTION II DIRECT SUPPORT MAINTENANCE PROCEDURES

5.2 PANELS AND GUARD REPAIR.

This task covers:

Repair

INITIAL SETUP

Equipment Conditions:

Panel(s) and/or guard removed.

Tools:

Torch Set
 1, Section III, Appendix B

Repair.

- (1) Repair any minor sheet metal dents and bent edges by straightening using common sheet metal repair procedures.
- (2) Weld any cracks or breaks per MIL-B7883.
- (3) Touch-up any painted surfaces per TM 43-0139.

NOTE

FOLLOW-ON MAINTENANCE:
Install panel(s) and/or guard.

5.3 CONTROL BOX COVER REPAIR.

This task covers:

Repair

INITIAL SETUP

Tools:

- Brush
1, Section III, Appendix B
- Torch Set
1, Section III, Appendix B
- General Safety Instructions:

WARNING

Acetone and methyl-ethyl ketone (MEK) are flammable and their vapors can be explosive. Repeated or prolonged skin contact or inhalation of vapors can be toxic. Use in a well ventilated area, wear gloves, and keep away from sparks or flame.

Equipment Conditions:

Control box cover removed.

Materials/Parts:

- Gaskets (2)
Figure F-5, Appendix F
- Gasket
Figure F-4, Appendix F
- General Purpose Adhesive
14, Appendix E
- Wiping Rag
3, Appendix E
- Acetone
18, Appendix E
- Methyl-Ethyl Ketone
19, Appendix E

Repair.

- (1) Remove as much old gasket material (1) or (2) as possible by pulling or scraping it away from the control box cover (3).

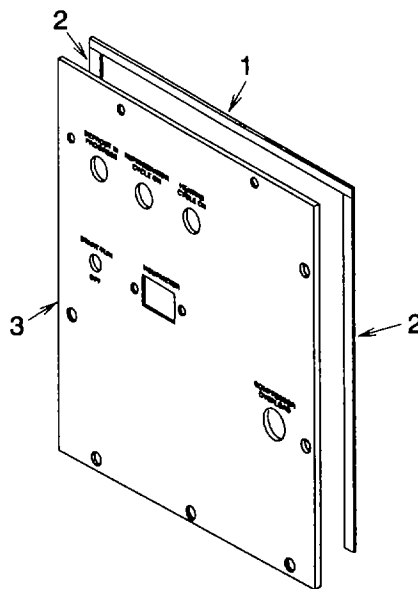

Figure 5-1. Control Box Cover.

5.3 CONTROL BOX COVER REPAIR. - Continued

- (2) Soften and remove old adhesive and gasket (1) or (2) residue, using acetone or methyl-ethyl ketone (MEK) and a stiff brush.
- (3) Repair any minor sheet metal dents and bent edges by straightening using common sheet metal repair procedures.
- (4) Weld any cracks or breaks per MIL-B-7883.
- (5) Touch-up any painted surfaces per TM 43-0139.
- (6) Fabricate new gasket(s) (1) or (2) per appendix F.
- (7) Be sure that the attaching surface of the control box cover (3) is clean and free of paint and old adhesive material.
- (8) Coat the mating surfaces of the control box cover (3) and gasket(s) (1) or (2) with adhesive. Let both surfaces air dry until adhesive is tacky, but will not stick to fingers.
- (9) Starting with an end, carefully press gasket (1) or (2) onto the control box cover (2). Press firmly overall to ensure complete contact.

NOTE

**FOLLOW-ON MAINTENANCE:
Install control box cover.**

5.4 CIRCUIT BREAKER COVER REPAIR.

This task covers:

Repair

INITIAL SETUP

Tools:

- Brush
1, Section III, Appendix B
- Torch Set
1, Section III, Appendix B
- General Safety Instructions:

WARNING

Acetone and methyl-ethyl ketone (MEK) are flammable and their vapors can be explosive. Repeated or prolonged skin contact or inhalation of vapors can be toxic. Use in a well ventilated area, wear gloves, and keep away from sparks or flame.

Equipment Conditions:

Circuit breaker cover removed.

Materials/Parts:

- Gaskets (2)
Figure F-6, Appendix F
- Gaskets (2)
Figure F-7, Appendix F
- General Purpose Adhesive
14, Appendix E
- Wiping Rag
3, Appendix E
- Acetone
18, Appendix E
- Methyl-Ethyl Ketone
19, Appendix E

Repair.

- (1) Remove as much old gasket material (1) or (2) as possible by pulling or scraping it away from the circuit breaker cover (3).

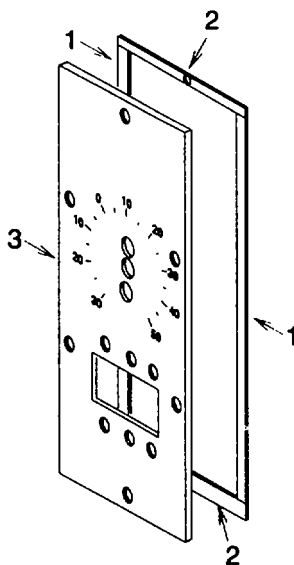

Figure 5-2. Circuit Breaker Cover.

5.4 CIRCUIT BREAKER COVER REPAIR. - Continued

- (2) Soften and remove old adhesive and gasket (1) or (2) residue, using acetone or methyl-ethyl ketone (MEK) and a stiff brush.
- (3) Repair any minor sheet metal dents and bent edges by straightening using common sheet metal repair procedures.
- (4) Weld any cracks or breaks per MIL-B-7883.
- (5) Touch-up any painted surfaces per TM 43-0139.
- (6) Fabricate new gasket(s) (1) or (2) per appendix F.
- (7) Be sure that the attaching surface of the circuit breaker cover (3) is clean and free of paint and old adhesive material.
- (8) Coat the mating surfaces of the circuit breaker cover (3) and gasket(s) (1) or (2) with adhesive. Let both surfaces air dry until adhesive is tacky, but will not stick to fingers.
- (9) Starting with an end, carefully press gasket (1) or (2) onto the circuit breaker cover (2). Press firmly overall to ensure complete contact.

NOTE

**FOLLOW-ON MAINTENANCE:
Install circuit breaker cover.**

5.5 FAN DRIVE SHAFT REPLACEMENT.

This task covers:

- a. Removal b. Installation

INITIAL SETUP

Equipment Conditions:

Refrigeration unit shut down (para 2.7) and power disconnected.

Evaporator fan removed (para 4.37).

Condenser coil removed (para 5.30).

Sheave removed (para 4.33).

General Safety Instructions:

WARNING

High voltage and exposed rotating parts are used in the refrigeration unit. Personal injury can result if power is connected.

- a. Removal. Remove fan drive shaft (1).
- b. Installation. Install fan drive shaft (1).

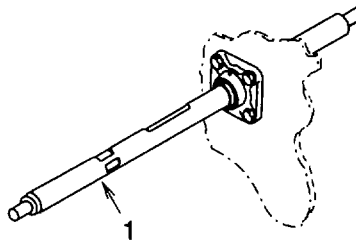

Figure 5-3. Fan Drive Shaft

NOTE

FOLLOW-ON MAINTENANCE:

Install sheave (para 4.33).

Install and adjust V-belt (para 4.31).

Install condenser coil (para 5.30).

Install evaporator fan (para 4.37).

Connect power and put unit back into service.

5.6 REFRIGERATION SYSTEM REPAIRS.

The refrigeration system must be totally discharged (para 5.8) before any maintenance is performed on system components. Leak testing (para 5.11) and dehydrator replacement (para 5.15) are required after any system component has been removed and replaced. The system must be properly evacuated (para 5.12) and charged (para 5.13) to function correctly.

5.7 SERVICE MANIFOLD INSTALLATION.

This task covers:

a. Repair

b. Removal

INITIAL SETUPTools:

Gloves

1, Section III, Appendix B

Goggles

1, Section III, Appendix B

Refrigerant Recovery and Recycle Unit

5, Section III, Appendix B

Equipment Conditions:

Refrigeration unit shut down (para 2.7) and power disconnected.

Both side doors open.

Front door open.

General Safety Instructions:**WARNING**

- **High voltage and rotating parts are used in the refrigeration unit. Personal injury can result if power is connected.**
- **Dangerous chemical refrigerant under pressure is used in the operation of this equipment. Use great care to avoid contact with liquid refrigerant. Work in a well ventilated area.**

General Safety Instructions:**WARNING**

Sudden and irreversible tissue damage can result from freezing. Wear gloves and face protector or safety glasses in any situation where skin or eye contact with refrigerant is possible.

Heat may cause the refrigerant to decompose and release irritating, toxic, and corrosive gases. Prevent contact of refrigerant with flame or hot surfaces.

Compressor lubricating oil is caustic. Wear gloves and a face protector or safety glasses in any situation where skin or eye contact is possible. If oil does contact skin, wash with soap and water.

a. Installation.**CAUTION**

Using excessive force when opening or closing valves can cause damage to the valve seats.

NOTE

The compressor shut off valves can be adjusted to three positions, fully closed to block the refrigerant tubes and isolate the compressor and service port, fully open to allow flow from piping to compressor but not the service port, and cracked (one turn closed from fully open) to allow flow from piping to compressor and service port on valve.

- (1) Remove two shut off valve caps and turn the shut off valves fully counterclockwise to backseat them.

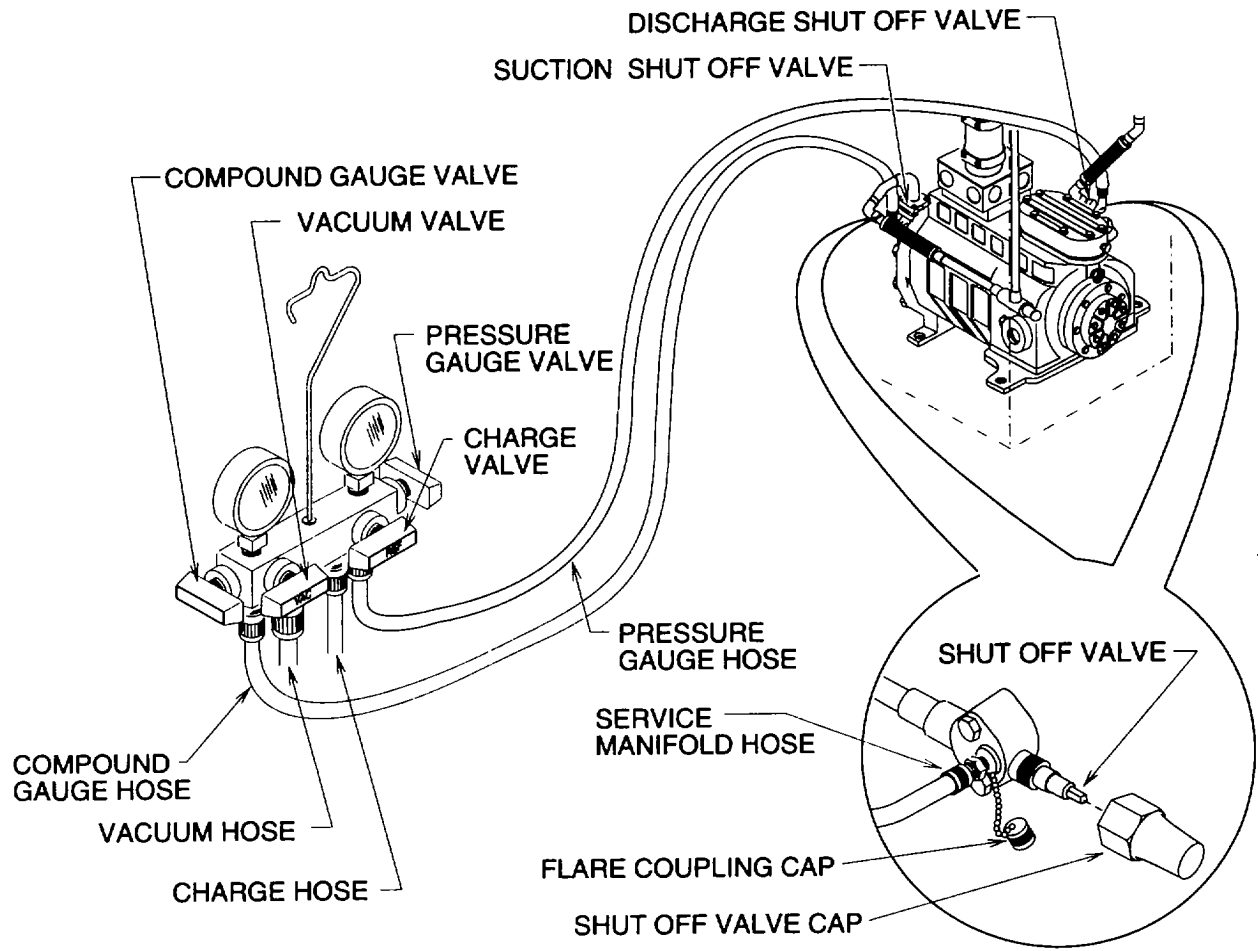

Figure 5-4. Service Manifold Installation

5.7 SERVICE MANIFOLD INSTALLATION. - Continued

- (2) Remove two flare coupling caps.
- (3) Check that all four service manifold valves are closed.

NOTE

Push switches in side doors will prevent refrigeration unit from operating if door is open. Do not pass the service manifold hoses through the side doors if the refrigeration unit will need to be operated.

- (4) Pass service manifold hoses through front doors and connect service manifold pressure gauge hose to discharge flare coupling and compound gauge hose to suction flare coupling.
- (5) Connect service manifold charge hose to recovery unit.
- (6) Turn discharge and suction shut off valves one turn clockwise to crack open valves.
- (7) Open service manifold compound gauge valve and charge valve. Operate recovery unit and allow refrigerant to purge for 3-5 seconds. Close compound gauge and charge valves then shut down recovery unit.
- (8) Open service manifold compound gauge valve and charge valve. Operate recovery unit and allow refrigerant to purge 35 seconds. Close compound gauge and charge valves then shutdown recovery unit.

b. Removal.

- (1) Turn shut off valves fully counterclockwise to backseat them.
- (2) Open service manifold pressure and compound gauge valves.
- (3) Open service manifold charge valve. Operate recovery unit and allow refrigerant to purge from hoses.
- (4) Close service manifold valves.
- (5) Shut down recovery unit.
- (6) Disconnect service manifold pressure gauge hose from discharge flare coupling and compound gauge hose from suction flare coupling.
- (7) Install two shut off valve and flare coupling caps.

NOTE

**FOLLOW-ON MAINTENANCE:
Close front bottom doors.
Close both side doors.**

5.8 DISCHARGING THE REFRIGERANT SYSTEM.

This task covers:

Discharge

INITIAL SETUP

Equipment Conditions:

Service manifold installed (para 5.7).

Discharge.

- (1) Check that the refrigerant system has not been pumped down (para 4.48). If it has, open necessary valves (para 4.8) to allow discharge of all refrigerant.

CAUTION

Follow instructions for specific refrigerant recovery unit being used to avoid compressor oil loss. Loss of oil could result in compressor damage.

NOTE

Venting tetrafluoroethane refrigerant into the atmosphere rather than recovering it is subject to pending EPA restrictions. Venting the refrigerant may be a violation of public law and subject to severe penalties.

- (2) Open service manifold pressure and compound gauge valves.
- (3) Open service manifold charge valve. Operate recovery unit until all refrigerant has been removed from system.
- (4) Close service manifold valves.
- (5) Shut-down refrigerant recovery unit.

5.8 DISCHARGING THE REFRIGERANT SYSTEM. - Continued

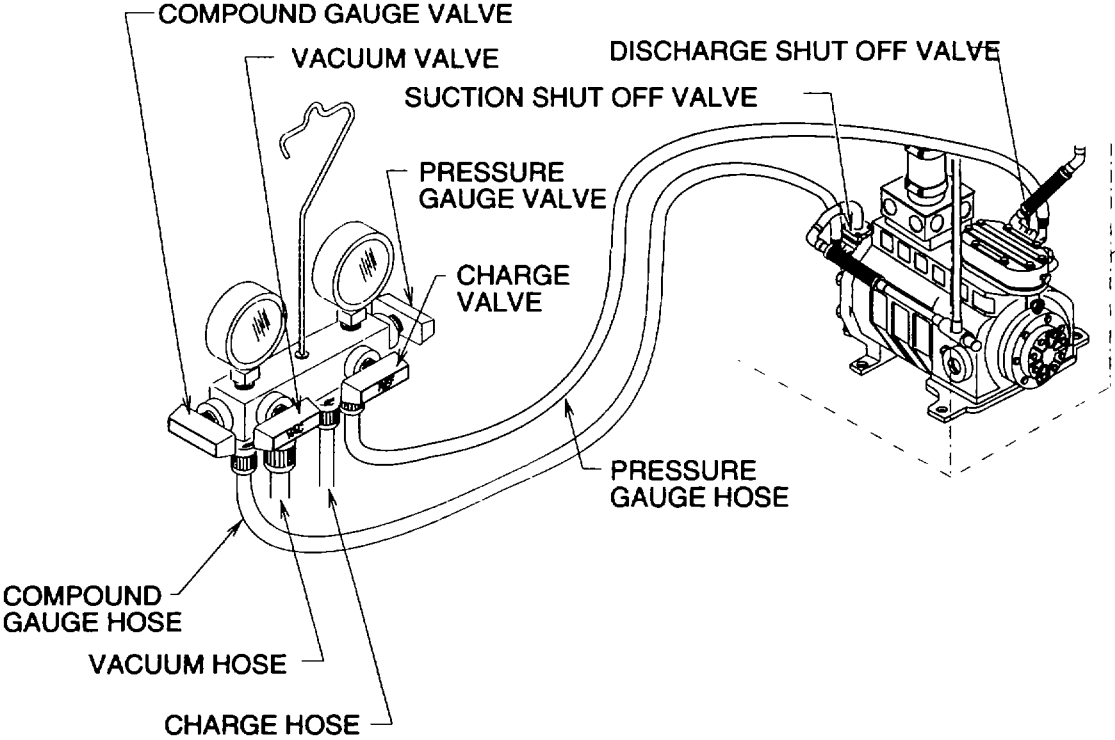

Figure 5-5. Discharging Refrigerant

5.9 PURGING THE REFRIGERANT SYSTEM.

This task covers:

Purge

INITIAL SETUP

Tools:

Nitrogen Regulator
6, Section III, Appendix B

Materials/Parts:

Nitrogen
11, Appendix E
Equipment Conditions:

Refrigeration system discharged (para 5.8).

General Safety Instructions:

WARNING

Never pressurize refrigerant lines with oxygen, mixture with oil could cause an explosion.

The pressure in a nitrogen cylinder can exceed 2000 psi. A nitrogen pressure regulator should be used at all times to avoid personal injury.

Nitrogen is an inert gas that can cause suffocation and must be discharged in a well ventilated area.

Purge. The refrigeration system must be purged with dry nitrogen before brazing is performed on any component. A flow of dry nitrogen should be continued during all brazing operations to minimize internal oxidation and scaling.

- (1) Disconnect charge hose from recovery unit and connect to nitrogen regulator and nitrogen tank.
- (2) Disconnect the compound gauge hose from the service manifold and place end in a suitable container to catch any oil that may come out.
- (3) Be sure the service manifold compound gauge and vacuum valves are closed.
- (4) Open the service manifold pressure gauge and charge valves.
- (5) Open the nitrogen tank valve and adjust the regulator so that approximately 1-2 cfm (0.028-0.057 m³/minute) of nitrogen flows through the system.
- (6) Check discharge from the hose attached to the suction service valve to be sure that no oil is being forced out of the system.
- (7) Perform any brazing/debrazing operations necessary (para 5.10).
- (8) When purging is completed, close nitrogen tank valve.
- (9) Disconnect the charge hose from nitrogen regulator.
- (10) Connect the compound gauge hose to service manifold.

5.9 PURGING THE REFRIGERANT SYSTEM. - Continued

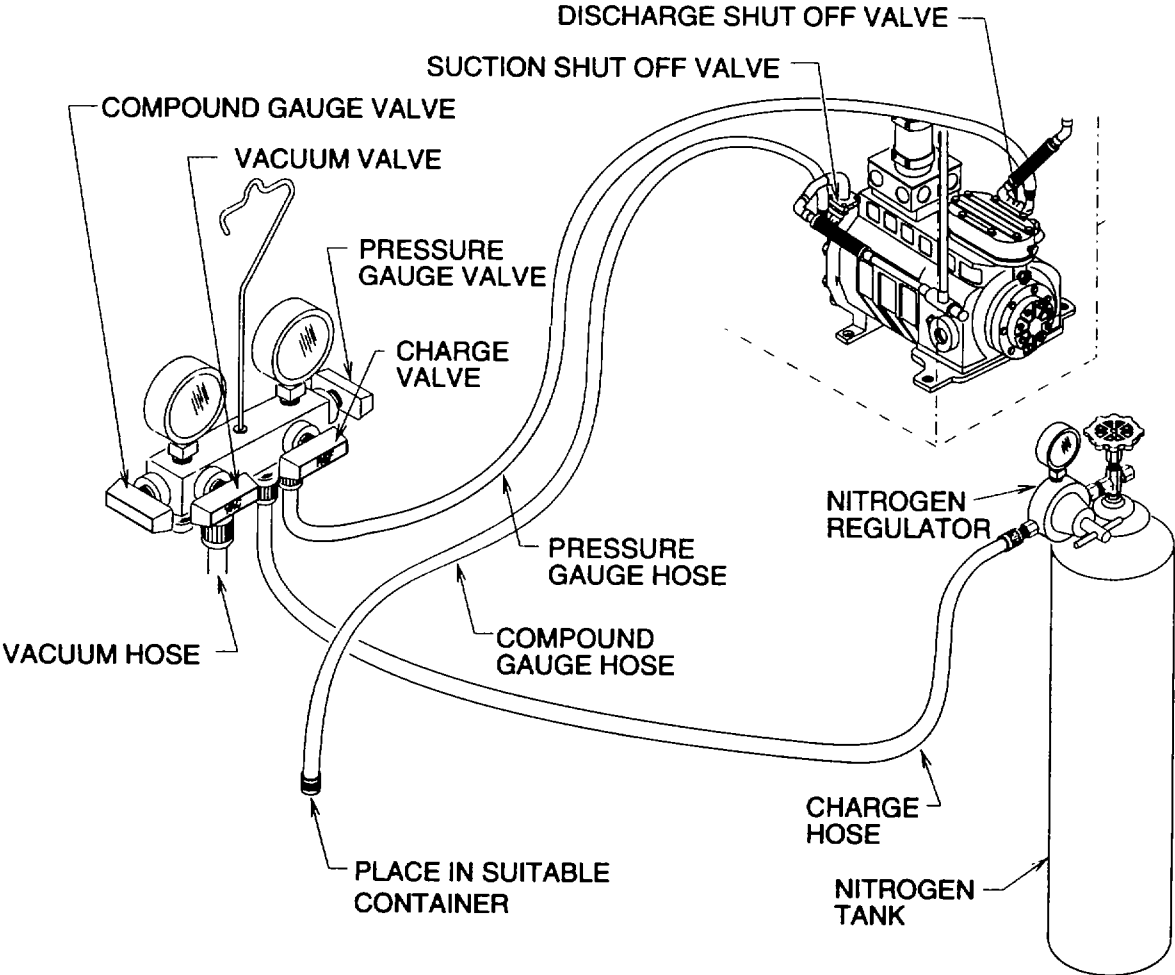

Figure 5-6. Nitrogen Tank Connection

5.10 BRAZING/DEBRAZE PROCEDURE.

 This task covers:

a. Debraze

b. Clean

c. Braze

INITIAL SETUPMaterials/Parts:

Brazing Alloy
15 or 16, Appendix E

Brazing Flux
9, Appendix E

Rags
3, Abrasive E

Abrasive Cloth
13, Appendix E

Equipment Conditions:

Refrigeration system discharged (para 5.8) and
purged (para 5.9).

General Safety Instructions:**WARNING**

Brazing alloys and flux contain materials which are hazardous to health. Avoid breathing vapors or fumes from brazing Cloth operations. Perform operations only in well ventilated areas. Wash hands with soap and water after handling brazing alloys and flux. Wear gloves and protective goggles or face shield to protect against burns.

a. Debraze.

- (1) Protect wiring harnesses and other components with appropriate heat shields.

NOTE

It may be easier to access a component by cutting or debrazing the copper lines in accessible areas and removing part of the interconnecting tubing with the component.

- (2) If debrazing a joint on a valve, disassemble the valve to the extent possible and wrap all but the joint with wet rag to act as a heat sink.

5.10 BRAZING/DEBRAZE PROCEDURE. - Continued**WARNING**

Never use a heating torch on any part that contains refrigerant. Heat may cause the refrigerant to decompose and release irritating, toxic, and corrosive gases. All refrigerant must be discharged from the system and the entire system must be purged with dry nitrogen before beginning any brazing operation.

CAUTION

If heat is applied slowly, or only on one side, the entire component or length of tubing will be heated and filler alloy in adjacent joints may also be melted.

- (3) Check that the system is being purged (para 5.9) and apply sufficient heat uniformly around the joint to quickly melt the filler alloy. Remove heat as soon as the joint is separated.
 - b. Clean. All filler alloy must be cleaned from debrazed joints before reassembly. Heat each piece of the joint until the filler is melted and then wipe it away with a wire brush. Be sure no filler alloy or other debris is left inside any tubing, fitting, or component. Use abrasive cloth as necessary to clean joints.
 - c. Braze.
 - (1) Protect wiring harnesses and other components with appropriate heat shields.

NOTE

- All joints, except those provided with flare fittings, are made by brazing in accordance with MIL-B-7883, except that radiographic examination is not required.
 - Grade IV or VI brazing alloy and Type-B flux, as specified in MIL-B7883, must be used for all copper to brass joints. Grade III brazing alloy may be substituted for Grade IV or VI for copper to copper joints, flux is not required for copper to copper joints.
- (2) If brazing a joint on a valve, disassemble the valve to the extent possible and wrap all but the joint with a wet rag to act as a heat sink.

NOTE

If interconnecting tubing was removed with a component, braze tubing to the new components before installation.

- (3) Position component or assembly into place.

WARNING

Never use a heating torch on any part that contains refrigerant. Heat may cause the refrigerant to decompose and release irritating, toxic, and corrosive gases. All refrigerant must be discharged from the system and the entire system must be purged with dry nitrogen before beginning any brazing operation.

CAUTION

- **If heat is applied slowly, or only on one side, the entire component or length of tubing will be heated and filler alloy in adjacent joints may also be melted.**
 - **Brazing a joint without nitrogen flowing through the tubing, will cause deposits to form on the inside of the tube and may obstructions in the refrigeration system or equipment damage.**
- (4) Check that the system is being purged (para 5.9) and apply sufficient heat uniformly around the joint to quickly melt the filler alloy. Remove heat and stop purging (para 5.9) as soon as brazing is completed.

5.11 LEAK TESTING THE REFRIGERANT SYSTEM.

 This task covers:
Testing

INITIAL SETUPTools:

Nitrogen Regulator
6, Section III, Appendix B

Materials/Parts:

Nitrogen
11, Appendix E
Refrigerant R-134a
12, Appendix E

Equipment Conditions:

Service manifold installed (para 5.7).

General Safety Instructions:**WARNING**

Never pressurize refrigerant lines with oxygen, mixture with oil could cause an explosion.

The pressure in a nitrogen cylinder can exceed 2000 psi. A nitrogen pressure regulator should be used at all times to avoid personal injury.

Nitrogen is an inert gas that can cause suffocation and must be discharged in a well ventilated area.

Testing.**NOTE**

- **To perform leak test, it is necessary that the system be pressurized with a proportion of refrigerant gas.**
 - **The electronic gas tester is highly sensitive to the presence of a minute quantity of gas in the air, and is quite effective in the detection of small leaks. However, due to rapid dispersion of refrigerant gas into surrounding air, difficulty may be encountered in pinpointing large leaks. The detector must be used in a well ventilated area but draft free area. Use procedures contained in TM 9-4940-435-14, "Leak Detector, Refrigerant Gas".**
- (1) To pressurize a system that has some refrigerant charge.
- (a) Connect the charge hose to a refrigerant cylinder containing refrigerant R-134a set to deliver gas only.
 - (b) Check that service manifold vacuum valve is closed.
 - (c) Open the service manifold compound gauge, pressure gauge, and charge valves.
 - (d) Open refrigerant cylinder valve and pressurize system to 100 psi (7.1 kg/cm²).

- (2) To pressurize a system that has been discharged and purged.
 - (a) Connect the charge hose to a refrigerant cylinder containing refrigerant R-134a set to deliver gas only.
 - (b) Check that service manifold vacuum valve is closed.
 - (c) Open the service manifold compound gauge, pressure gauge, and charge valves.
 - (d) Open refrigerant cylinder valve and pressurize system to 40-50 psi (2.83.5 kg/cm²).
 - (e) Close service manifold valves and refrigerant cylinder valve.
 - (f) Disconnect charge hose from the refrigerant cylinder and connect it to a nitrogen regulator and nitrogen cylinder.
 - (g) Open the service manifold compound gauge, pressure gauge, and charge valves.
 - (h) Open nitrogen cylinder valve and pressurize system to 350 psi (24.7 kg/cm²).
- (3) Test for leaks at all points of possible leakage using a refrigerant gas leak detector. If a leak is found, take necessary steps to replace damaged components or repair leak.
- (4) If no leak was found and refrigerant only was used to pressurize the system, check refrigeration unit charge (para 5.13).
- (5) If no leak was found and nitrogen was used to pressurize the system, discharge (para 5.8), evacuate (para 5.12), and charge (para 5.13) the refrigeration unit.

5.12 EVACUATING THE REFRIGERANT SYSTEM.

This task covers:

Evacuate

INITIAL SETUP

Equipment Conditions:

Refrigerate system discharged (para 5.8).

Evacuate. The refrigeration system must be evacuated to remove all moisture and non-condensables before if is charged.

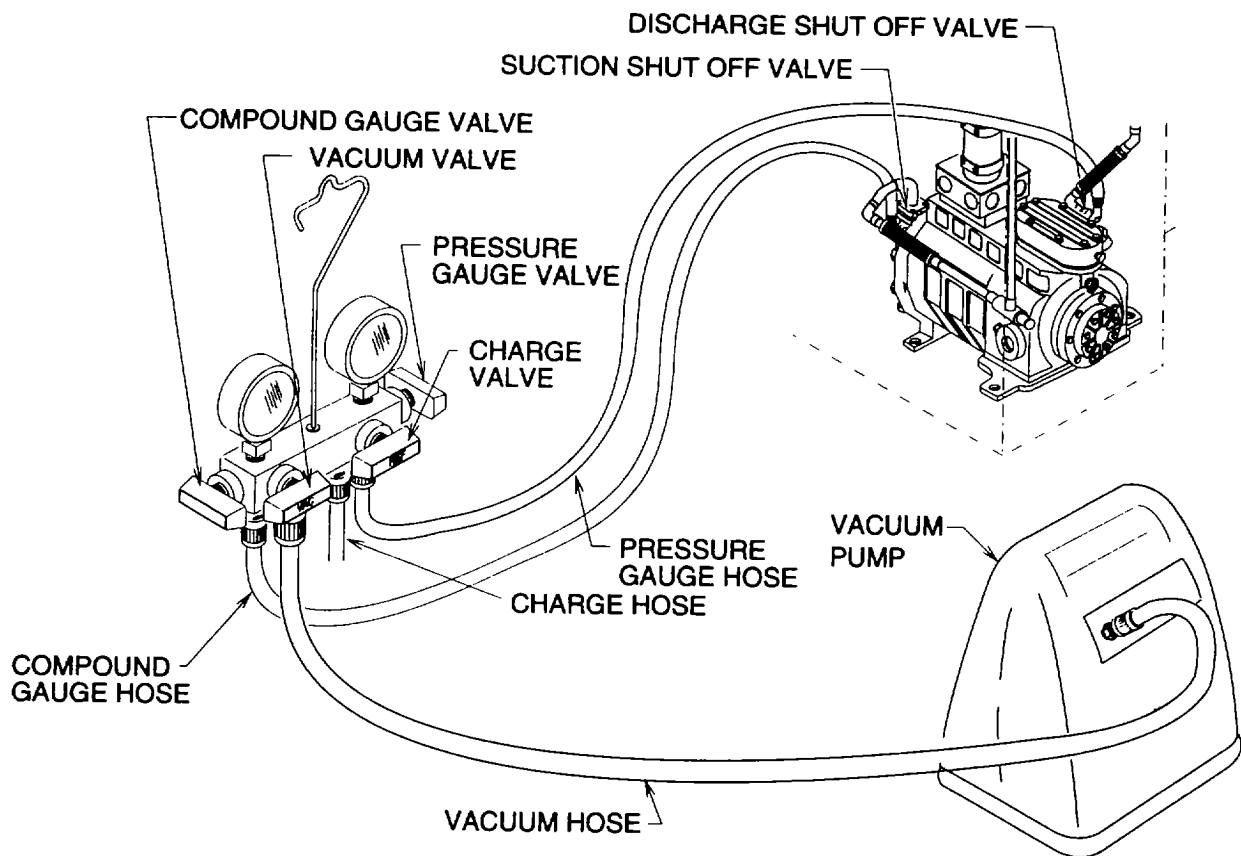

Figure 5-7. Evacuation of Refrigerant System

- (1) Check that new dehydrator was installed. If not, install one (para 5.15).
- (2) Check that service manifold charge valve is closed.
- (3) Connect the vacuum hose to vacuum pump and start pump.
- (4) Open service manifold high pressure gauge, compound gauge, and vacuum valves.
- (5) Run vacuum pump until at least 29 inches of mercury is measured on compound gauge. Continue running vacuum pump for one more hour, while observing the compound gauge. If gauge needle moves back and forth, you have a leak which must be located and corrected (para 5.10).

NOTE

Inability to reach and hold 29 inches of mercury may indicate either a leak or a problem with the vacuum pump.

- (6) Close service manifold vacuum valve and stop vacuum pump. Note reading on compound gauge and observe for 10 minutes. If pressure rises, moisture may still be in the system or a leak exists. If pressure rose, repeat evacuation and re-check. If the pressure rise occurs again at the same speed, a leak is in the system and must be found (para 5.11). If the pressure rise was slower the second time, moisture remains in the system and the evacuation process must be repeated until there is no rise.
- (7) Close service manifold high pressure gauge and compound gauge valves.
- (8) Disconnect the vacuum hose from vacuum pump.

NOTE

**FOLLOW-ON MAINTENANCE:
Charge the refrigeration system (para 5.13).**

5.13 CHARGING THE REFRIGERANT SYSTEM.

 This task covers:

- a. Full Charge b. Partial Charge
-

INITIAL SETUPMaterials/Parts:

Refrigerant R-134a
12, Appendix E

Equipment Conditions:

Service manifold installed (para 5.7).
Refrigeration system evacuated (para 5.12)

General Safety Instructions:**WARNING**

- **Dangerous chemical refrigerant under pressure is used in the operation of this equipment. Use great care to avoid contact with liquid refrigerant.**
 - **Sudden and irreversible tissue damage can result from freezing. Wear gloves and a face protector or safety glasses in any situation where skin or eye contact with refrigerant is possible.**
 - **Heat may cause the refrigerant to decompose and release irritating, toxic, and corrosive gases. Prevent contact of refrigerant with flame or hot surfaces.**
 - **Never introduce high discharge pressure into a refrigerant cylinder. This can cause the cylinder to rupture and injure personnel.**
-

a. Full Charge.**CAUTION**

The system must be evacuated before charging. Moisture in the system will prevent the refrigeration unit from operating properly.

- (1) Connect the charge hose to a tank containing refrigerant R-134a set to deliver gas and the vacuum hose to reclaim unit.
- (2) Check that compound gauge and pressure gauge valves are closed.
- (3) Open vacuum and charge valves.
- (4) Open refrigerant tank valve. Operate reclaim unit for 3 to 5 seconds to purge hoses.
- (5) Close refrigerant tank, vacuum, and charge valves then stop reclaim unit.

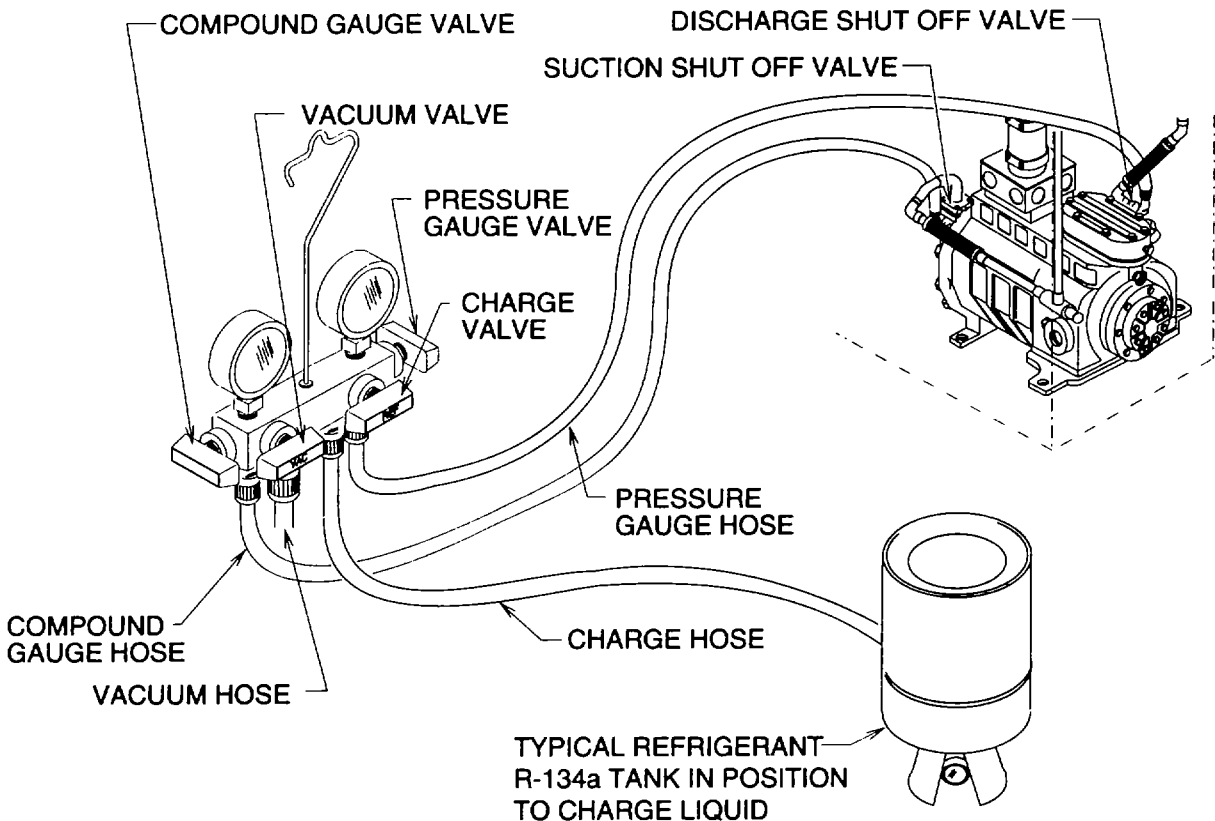

Figure 5-8. Refrigerant Charging (Total System)

- (6) Set refrigerant tank to deliver liquid only.
- (7) Place refrigerant tank on an accurate scale to measure and record weight.

CAUTION

Never introduce liquid refrigerant into the suction shut off valve. This can cause damage to the compressor.

- (8) With system shut down, open refrigerant tank, pressure gauge, and charge valves. Allow liquid refrigerant to enter system until tank weight has decreased by 14 pounds (6.4 kg) or until system pressure has equalized, whichever occurs first.
- (9) Close refrigerant tank, charge, and pressure gauge valves.

5.13 CHARGING THE REFRIGERANT SYSTEM. - Continued**NOTE**

If 14 pounds (6.4 kg) full charge was obtained, skip steps (10) through (15).

- (10) Connect power at power source.
- (11) Turn refrigeration unit on (para 4.8) and operate at desired temperature setting.
- (12) Set refrigerant tank to deliver gas only.
- (13) Check that all service manifold valves are closed.

WARNING

Never introduce high discharge pressure into a refrigerant tank. This can cause the tank to rupture and injure personnel.

CAUTION

Never introduce liquid refrigerant into the suction shut off valve. This can cause damage to the compressor.

- (14) Open refrigerant tank, compound gauge, and charge valves.
- (15) Monitor weight of the refrigerant tank until total 14 pounds (6.4 kg) charge is obtained. When system is fully charged, immediately close refrigerant tank, compound gauge, and charge valves.
- (16) Run refrigeration unit for 15 minutes and observe sight glass through left side condenser door.
 - (a) Green or chartreuse center means refrigerant moisture content is acceptable.
 - (b) Yellow center means there is too much moisture in system. Discharge (para 5.8), replace dehydrator (para 5.15), leak check (para 5.11), evacuate (para 5.12), and charge again.
- (17) Be sure all service manifold valves are closed.
- (18) Shut off refrigeration unit (para 2.7).

b. Partial Charge.

- (1) Connect the charge hose to a tank containing refrigerant R-134a set to deliver gas and the vacuum hose to reclaim unit.
- (2) Check that compound gauge and pressure gauge valves are closed.
- (3) Open vacuum and charge valves.
- (4) Open refrigerant tank valve. Operate reclaim unit for 3 to 5 seconds to purge hoses.
- (5) Close refrigerant tank, vacuum, and charge valves then stop reclaim unit.

- (6) Connect power at power source.
- (7) Turn refrigeration unit on (para 4.8) and operate at desired temperature setting.
- (8) Set refrigerant tank to deliver gas only.
- (9) Check that all service manifold valves are closed.

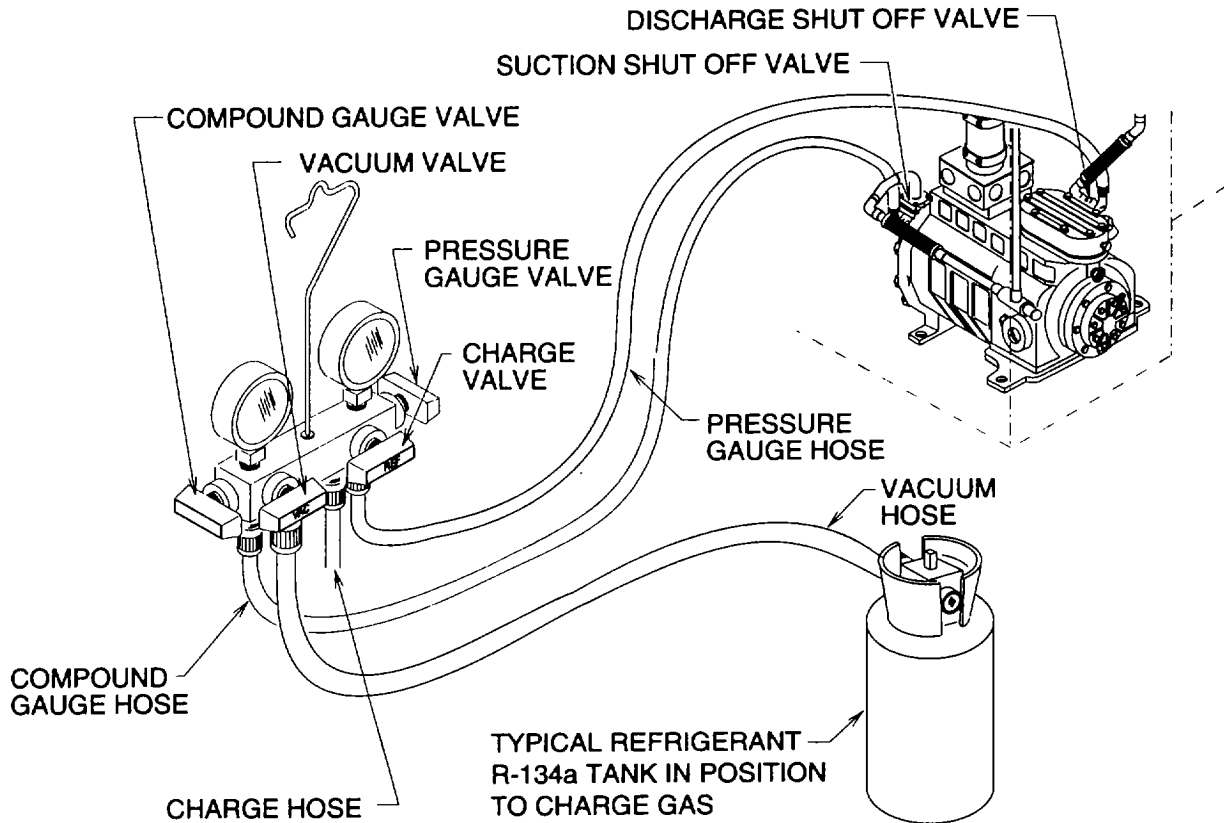

Figure 5-9. Refrigerant Charging (Partial System/Small Quantity Charge)

5.13 CHARGING THE REFRIGERANT SYSTEM. - Continued**WARNING**

Never introduce high discharge pressure into a refrigerant tank. This can cause the tank to rupture and injure personnel.

CAUTION

Never introduce liquid refrigerant into the suction shut off valve. This can cause damage to the compressor.

- (10) Open refrigerant tank, compound gauge, and charge valves.
- (11) Run refrigeration unit for 15 minutes and observe sight glass through left side condenser door.
 - (a) Green or chartreuse center means refrigerant moisture content is acceptable.
 - (b) Yellow center means there is too much moisture in system. Discharge (para 5.8), replace dehydrator (para 5.15), leak check (para 5.11), evacuate (para 5.12), and charge again.
 - (c) Milky white or bubbly liquid means system has low charge.
 - (d) Clean bubble free liquid around center means the system is fully charged.

CAUTION

Never introduce liquid refrigerant into the low pressure (suction) charging valve. This can cause damage to the compressor.

- (12) If charge is low, set refrigerant tank to deliver gas only.

WARNING

Never introduce high discharge pressure into a refrigerant cylinder. This can cause the cylinder to rupture and injure personnel.

- (13) Check that pressure gauge valve is closed.
- (14) Open refrigerant tank, compound gauge, and charge valves.
- (15) Charge until sight glass remains clear and bubble free for 15 minutes.
- (16) When system is fully charged, immediately close refrigerant tank, compound gauge, and charge valves.
- (17) Shut off refrigeration unit (para 2.7).

NOTE

**FOLLOW-ON MAINTENANCE:
Remove service manifold (para 5.7).**

5.14 REFRIGERANT SYSTEM PRESSURE CHECK

This task covers:

- a. Testing
-

INITIAL SETUP

Equipment Conditions:

Service manifold installed (para 5.7).

Testing.

- (1) Check that all four service manifold valves are closed.
- (2) Service manifold compound and pressure gauges should indicate the same pressure. Check the reading with the appropriate column in Table 5-1. If the system is even partially charged, the pressure should be approximately equal to that shown in the table for the appropriate ambient temperature. If the pressure is considerably less than shown in the table, the system does not contain enough refrigerant to continue the pressure check. Leak test the refrigeration system (para 5.11).
- (3) Turn the refrigeration unit on (para 4.8) and operate at desired setting.
- (4) With the refrigeration unit operating, allow service manifold gauges to stabilize. Compare readings with those listed in Table 5-1.
 - (a) If discharge and suction pressure are at, or near, the same value, defrost solenoid valve (L2) or compressor (B1) failure is indicated.
 - (b) If discharge pressure is low and suction pressure is normal, a low refrigerant charge is indicated.
 - (c) If discharge pressure is normal and suction pressure is either high, or low, failure of the expansion valve is indicated.
 - (d) If discharge pressure is high and suction pressure is normal, refrigerant overcharge is indicated. If charge is correct, refer to troubleshooting procedures (para 5.1).
- (5) When pressure tests are completed, turn the refrigeration unit off (para 2.7) and disconnect power.

5.14 REFRIGERANT SYSTEM PRESSURE CHECK. - Continued

Table 5-1. Pressure Temperature Relationship of Saturated Refrigerant R-134a

Temperature		Pressure		Temperature		Pressure	
Deg° F	Deg ° C	psia	kg/cm2	Deg° F	Deg° C	psia	kg/cm2
-20		12.95	5.87	62	16.66	74.69	33.87
-18		13.63	6.18	64	17.77	77.36	35.08
-16		14.35	6.50	66	18.88	80.09	36.32
-14	-25.55	15.09	6.84	68	20	82.90	37.60
-12	-24.44	15.87	7.19	70	21.11	85.79	38.91
-10	-23.33	16.67	7.56	72	22.22	88.75	40.25
-8	-22.22	17.51	7.94	74	23.33	91.79	41.63
-6	-21.11	18.38	8.33	76	24.44	94.90	43.04
-4	-20.00	19.29	8.74	78	25.55	98.09	44.49
-2	-18.88	20.23	9.17	80	26.66	101.37	45.98
0	-17.77	21.20	9.61	82	27.77	104.73	47.50
2	-16.66	22.22	10.07	84	28.88	108.16	49.06
4	-15.55	23.27	10.55	86	30	111.69	50.66
6	-28.88	24.35	11.04	88	31.11	115.30	52.16
8	-27.77	25.48	11.55	90	32.22	118.99	53.97
10	-26.66	26.65	12.08	92	33.33	122.78	55.69
12	-11.11	27.86	12.63	94	34.44	126.65	57.44
14	-10.00	29.11	13.20	96	35.55	130.62	59.24
16	-8.88	30.41	13.79	98	36.66	134.68	61.08
18	-7.77	31.75	14.40	100	37.77	138.83	62.59
20	-6.66	33.14	15.03	102	38.88	143.07	64.86
22	-5.55	34.57	15.68	104	40	147.42	66.86
24	-4.44	36.05	16.35	106	41.11	151.86	68.88
26	-3.33	37.58	16.78	108	42.22	158.40	71.84
28	-2.22	39.16	17.76	110	43.33	161.04	73.04
30	-1.11	40.79	18.50	112	44.44	165.79	75.20
32	0	42.47	19.26	114	45.55	170.64	77.40
34	1.11	44.21	20.05	116	46.66	175.59	79.64
36	2.22	45.99	20.86	118	47.77	180.65	82.58
38	3.33	47.84	21.69	120	48.88	185.82	84.28
40	4.44	49.74	22.56	122	50	191.11	89.13
42	5.55	51.70	23.45	124	51.11	196.50	91.62
44	6.66	53.71	24.36	126	52.22	202.00	94.17
46	7.77	55.79	25.30	128	53.33	207.62	96.77
48	8.88	57.93	26.27	130	54.44	213.36	99.43
50	10	60.13	27.27	132	55.55	219.22	102.14
52	11.11	62.39	28.29	134	56.66	225.19	104.91
54	12.22	64.71	29.35	136	57.77	231.29	107.73
56	13.33	67.11	30.44	138	58.88	237.51	110.06
58	14.44	69.57	31.55	140	60	243.86	113.54
60	15.55	72.09	32.69	142	61.11	250.33	116.54

Table 5-1. Pressure Temperature Relationship of Saturated Refrigerant R-134a

Temperature		Pressure		Temperature		Pressure	
Deg° F	Deg° C	psia	kg/cm2	Deg° F	Deg° C	psia	kg/cm2
144	62.22	256.94	119.59	154	67.77	291.95	132.42
146	63.33	263.67	122.71	156	68.88	299.37	135.79
148	64.44	270.54	125.89	158	70	306.64	139.08
150	65.55	277.54	129.12	160	71.11	314.64	142.71
152	66.66	284.67	132.42				

Table 5-2. Nominal Operating Pressure At Suction And Discharge Shut Off Valves

Air Temperature Entering Evaporator Coil	Air Temperature Entering Condenser Coil 1100 F (430 C)
0° F (-18° C)	Suction 1 psi (7 kPa) Discharge 177 psi (1221 kPa)
35° F (2° C)	Suction 10 psi (69 kPa) Discharge 199 psi (1373 kPa)

NOTE

FOLLOW-ON MAINTENANCE:
Remove service manifold (para 5.7).

NOTE**Note flow direction prior to removal.**

- (2) Remove self locking nut (2), flat washer (3), bolt (4), flat washer (5), and dehydrator (6). Discard self locking nut.
- (3) If filter drier clamp (7) is damaged, remove four bolts (8), lock washers (9) and clamp. Discard lock washers.

b. Installation.

- (1) If removed, install filter drier clamp (7), four new lock washers (9) and bolts (8).

NOTE

- **Do not remove dehydrator protective caps until just before installation. This will minimize the risk of contaminating the dehydrator.**
- **Be sure to observe flow direction noted during removal.**

- (2) Install new dehydrator (6), flat washer (5), bolt (4), flat washer (3), and new self locking nut (2).
- (3) Tighten two flare nuts (1).

NOTE**FOLLOW-ON MAINTENANCE:**

Leak check (para 5.11), evacuate (para 5.12), and charge (para 5.13) the refrigeration system.
Close left side door.

b. Installation.

- (1) If removed, install strainer bracket (6) and two bolts (7).

NOTE

Be sure to observe flow direction noted during removal.

- (2) Install strainer (5), clamp (4), new lock washer (3), and bolt (2).
- (3) Tighten two flare nuts (1).

NOTE

FOLLOW-ON MAINTENANCE:

Replace dehydrator (para 5.15).

Leak check (para 5.11), evacuate (para 5.12), and charge (para 5.13) the refrigeration system.

Close right and left side doors.

5.17 ISOLATION VALVES REPLACEMENT

This task covers:

a. Removal

b. Installation

INITIAL SETUPMaterials/PartsAnti-Seize Tape
22, Appendix EEquipment Conditions:Refrigeration system discharged (para 5.13).
Left side door open.

a. Removal.

- (1) Remove two isolation valve caps (1).
- (2) Loosen two flare nuts (2) and move copper tubing (3) away from isolation valve (4) being careful not to bend or kink tubing.
- (3) Remove two isolation valves (4).

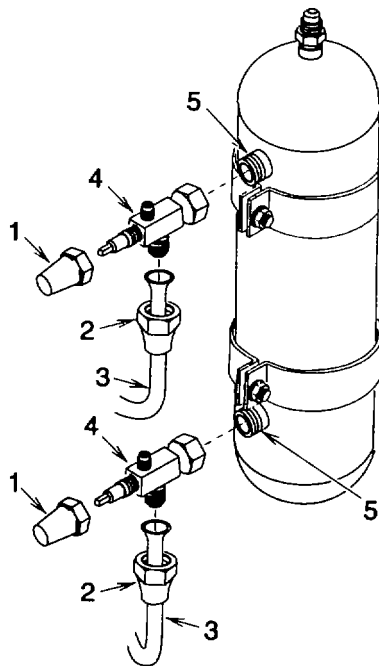

Figure 5-12. Isolation Valves

b. Installation.

- (1) Wrap anti-seize tape around receiver threads (5).
- (2) Install two isolation valves (4). Be sure valves are turned toward copper tubing (3) when tightened.
- (3) Aline copper tubing (3) and connect two flare nuts (2) to isolation valves (4).
- (4) Be sure two isolation valves (4) are open and install two isolation valve caps (1).

NOTE

FOLLOW-ON MAINTENANCE:

Replace dehydrator (para 5.15).

Leak check (para 5.11), evacuate (para 5.12), and charge (para 5.13) the refrigeration system.

Close left side door.

5.18 RECEIVER AND FUSIBLE PLUG REPLACEMENT

 This task covers:

- a. Removal b. Installation
-

INITIAL SETUPMaterials/Parts

Lubricating Oil
21, Appendix E
Self Locking Nuts (2)
15, Appendix g
Self locking Nut
17, Appendix G
Lock Washers (4)
7, Appendix G

Equipment Conditions:

Refrigeration system discharged (para 5.8).
Isolation valves removed (para 5.17).

General Safety Instructions:**WARNING**

Compressor lubricating oil is caustic. Wear gloves and a face protector or safety glasses in any situation where skin or eye contact is possible. If oil does contact skin, wash with soap and water.

a. Removal.

- (1) Remove two self locking nuts (1), flat washers (2), bolts (3), and flat washers (4). Discard self locking nuts.

NOTE**Note flow direction prior to removal.**

- (2) Remove self locking nut (5) flat washer (6), and receiver (7). Discard self locking nut.
- (3) If clamp brackets (8) are damaged, remove four bolts (9), lock washers (10), and two clamp brackets. Discard lock washers.
- (4) Remove fusible plug (11).

b. Installation.

- (1) Lightly coat fusible plug (11) copper gasket with compressor oil.
- (2) Install fusible plug (11) and tighten to between 25 and 30 ft lb (34 and 41 Nm).
- (3) If clamp brackets (8) were removed, install two clamp brackets, four new lock washers (10), and bolts (9).

NOTE

Be sure to observe flow direction noted during removal.

- (4) Install receiver (7), flat washer (6), and new self locking nut (5).
- (5) Install two flat washers (4), bolts (3), flat washers (2), and new self locking nuts (1).

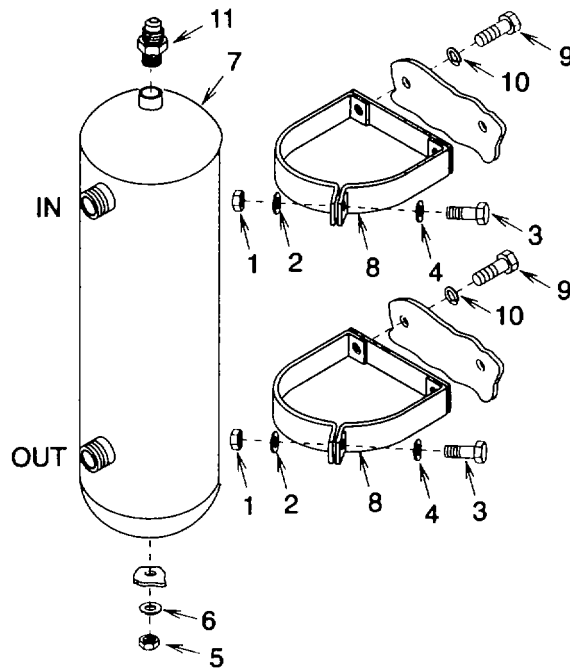

Figure 5-13. Receiver

NOTE

FOLLOW-ON MAINTENANCE:
 Install isolation valves (para 5.17).
 Replace dehydrator (para 5.15).

Leak check (para 5.11), evacuate (para 5.12), and charge (para 5.13) the refrigeration system.

5.19 PRESSURE REGULATOR VALVE (DISCHARGE) REPLACEMENT

 This task covers:

a. Removal

b. Installation

INITIAL SETUPMaterials/Parts

Lock Washer
1, Appendix G
Insulation Tape
10, Appendix E

Equipment Conditions:

Refrigeration system discharged (para 5.18) and
purged (para 5.9)..
Left side door open.

a. Removal.

- (1) Remove insulation (1) as necessary.
- (2) Remove bolt (2), lock washer (3), and clamp (4). Discard lock washer.
- (3) De-braze two fittings (5) then remove bushings (6) and pressure regulator valve (7) (para 5.10).

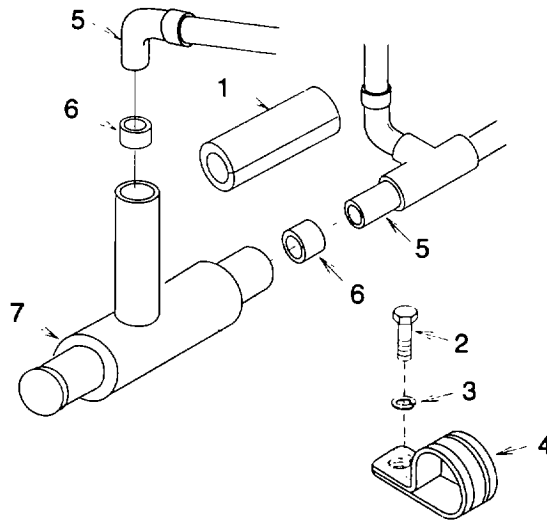

Figure 5-14. Pressure Regulator Valve (Discharge)

b. Installation.

- (1) Install pressure regulator valve (7) and two bushings (6) then braze the two bushings and fittings (5) onto pressure regulator valve (para 5.10).
- (2) Install clamp (4), new lock washer (3), and bolt (2).
- (3) Install insulation (1) and secure with insulation tape as necessary.

NOTE

FOLLOW-ON MAINTENANCE:
 Replace dehydrator (para 5.15).
 Leak check (para 5.11), evacuate (para 5.12), and charge (para 5.13) the refrigeration system.
 Close left side door.

5.20 PRESSURE REGULATOR VALVE (CRANKCASE) REPLACEMENT

This task covers:

a. Removal

b. Installation

INITIAL SETUP

Materials/Parts

Lock Washers
 1, Appendix G
 Insulation Tape
 10, Appendix E

Equipment Conditions:

Refrigeration system discharged (para 5.8) and
 purged (para 5.9).
 Right side door open.

a. Removal.

- (1) Remove insulation (1) as necessary.
- (2) Remove bolt (2), lock washer (3), and clamp (4). Discard lock washer.
- (3) De-braze two fittings (5) and remove pressure regulator valve (6) (para 5.10).

5.20 PRESSURE REGULATOR VALVE (CRANKCASE) REPLACEMENT. - Continued

Figure 5-15. Pressure Regulator Valve (Crankcase)

b. Installation.

- (1) Install pressure regulator valve (6) and braze two fittings (5) (para 5.10).
- (2) Install clamp (4), new lock washer (3), and bolt (2).
- (3) Install insulation (1) and wrap with insulation tape as necessary.

NOTE

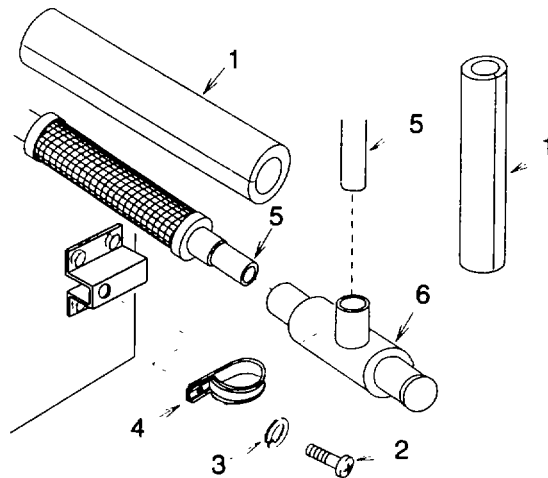
FOLLOW-ON MAINTENANCE:

Replace dehydrator (para 5.15).

Leak check (para 5.11), evacuate (para 5.12), and charge (para 5.13) the refrigeration system.

Close right side door.

5.21 CHECK VALVE REPLACEMENT

This task covers:

a. Removal

b. Installation

INITIAL SETUPMaterials/Parts

Insulation Tape
10, Appendix E

Equipment Conditions:

Refrigeration system discharged (para 5.8) and
purged (para 5.9).
Right side door open.

a. Removal.

- (1) Remove insulation (1) as necessary.
- (2) Remove two bolts (2).

NOTE

Note flow direction prior to removal.

- (3) De-braze two fittings (3) and remove check valve (4) (para 5.10).

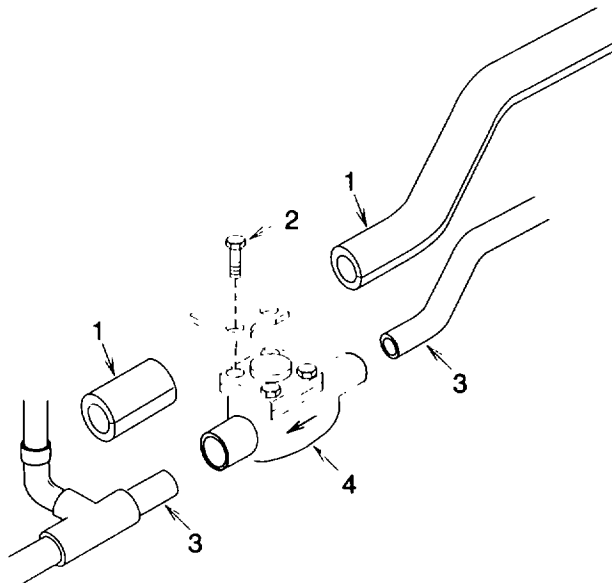

Figure 5-16. Check Valve

5.21 CHECK VALVE REPLACEMENT. - Continued

b. Installation.

CAUTION

Damage to valve can occur if not dis-assembled prior to installation.

NOTE

Be sure to observe flow direction noted during removal.

- (1) Install check valve (4) and braze two fittings (3) (para 5.10).
- (2) Install two bolts (2).
- (3) Install insulation (1) and secure with insulation tape as necessary.

NOTE

FOLLOW-ON MAINTENANCE:

Replace dehydrator (para 5.15).

Leak check (para 5.11), evacuate (para 5.12), and charge (para 5.13) the refrigeration system.

Close right side door.

5.22 METAL HOSE ASSEMBLY (DISCHARGE) REPLACEMENT

This task covers:

a. Removal

b. Installation

INITIAL SETUP

Materials/Parts

Insulation Tape
10, Appendix E

Equipment Conditions:

Refrigeration system discharged (para 5.8) and
purged (para 5.9)..
Right side door open.

a. Removal.

- (1) Remove insulation (1) as necessary.
- (2) De-braze two fittings (2) (para 5.10) and remove metal hose assembly (3).

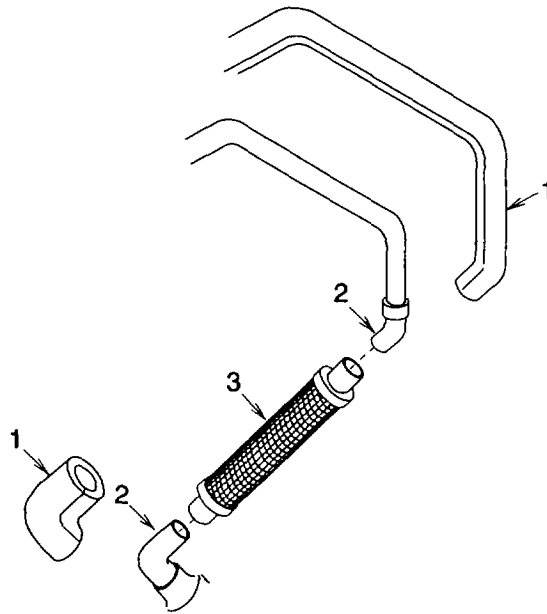

Figure 5-17. Metal Hose Assembly (Discharge)

b. Installation.

- (1) Install metal hose assembly (3) and braze two fittings (2) (para 5.10).
- (2) Install insulation (1) and secure with insulation tape as necessary.

NOTE

FOLLOW-ON MAINTENANCE:
Replace dehydrator (para 5.15).
Leak check (para 5.11), evacuate (para 5.12), and charge (para 5.13) the refrigeration system.
Close right side door.

5.23 METAL HOSE ASSEMBLY (SUCTION) REPLACEMENT.

 This task covers:

- a. Removal b. Installation
-

INITIAL SETUPMaterials/Parts:

Insulation Tape
10, Appendix E

Equipment Conditions:

Refrigeration system discharged (para 5.8) and
purged (para 5.9).
Right side door open.

a. Removal.

- (1) Remove insulation (1) as necessary.
- (2) De-braze two fittings (2) (para 5.10) and remove metal hose assembly (3).

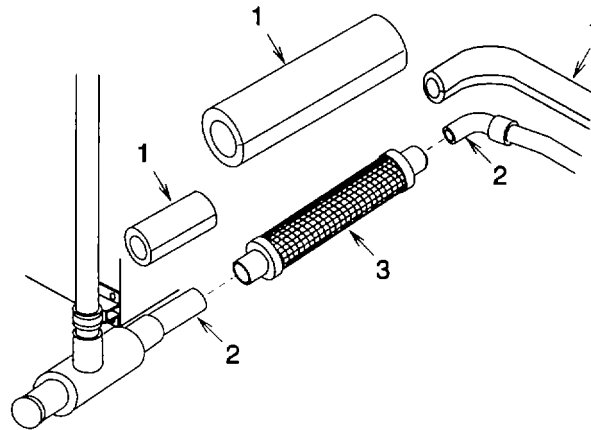

Figure 5-18. Metal Hose Assembly (Suction)

b. Installation.

- (1) Install metal hose assembly (3) and braze two fittings (2) (para 5.10).
- (2) Install insulation (1) and secure with insulation tape as necessary.

NOTE**FOLLOW-ON MAINTENANCE:**

Replace dehydrator (para 5.15).

Leak check (para 5.11), evacuate (para 5.12), and charge (para 5.13) the refrigeration system.
Close right side door.

5.24 ACCUMULATOR AND FUSIBLE PLUG REPLACEMENT.

This task covers:

a. Removal

b. Installation

INITIAL SETUPMaterials/Parts:

Lock Washers (4)
 7, Appendix G
 Self Locking Nut
 17, Appendix G
 Self Locking Nuts (2)
 15, Appendix G
 Lubricating Oil
 21, Appendix E
 Insulation Tape
 10, Appendix E

Equipment Conditions:

Refrigeration system discharged (para 5.8) and
 purged (para 5.9).

Right side door open.

General Safety Instructions:**WARNING**

Compressor lubricating oil is caustic. Wear gloves and a face protector or safety glasses in any situation where skin or eye contact is possible. If oil does contact skin, wash with soap and water.

a. Removal.

- (1) Remove insulation (1) as necessary.
- (2) De-braze two fittings (2) from accumulator (3) (para 5.10).
- (3) Remove two self locking nuts (4), flat washers (5), bolts (6), and flat washers (7). Discard self locking nuts.

NOTE**Note flow direction prior to removal.**

- (4) Remove self locking nut (8) and accumulator (3). Discard self locking nut.
- (5) If clamp brackets (9) are damaged and must be replaced, remove four bolts (10), lock washers (11), and two clamp brackets. Discard lock washers.
- (6) Remove fusible plug (12).

b. Installation.

- (1) Lightly coat fusible plug (12) copper gasket with compressor oil.
- (2) Install fusible plug (12) and tighten to between 25 and 30 ft lb (34 and 41 Nm).

5.24 ACCUMULATOR REPLACEMENT. - Continued

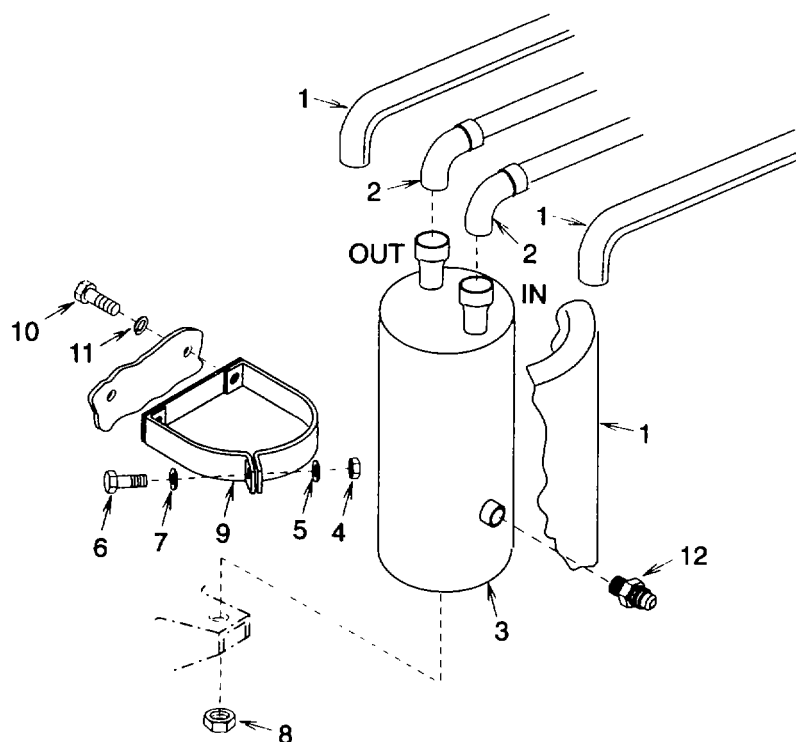

Figure 5-19. Accumulator

- (3) If clamp brackets (9) were removed, install two clamp brackets, four new lock washers (11), and bolts (10).

NOTE

Be sure to observe flow direction noted during removal.

- (4) Install accumulator (3) and new self locking nut (8).
- (5) Install two flat washers (7), bolts (6), flat washers (5), and new self locking nuts (4).
- (6) Braze two fittings (2) onto accumulator (3) (para 5.10).
- (7) Install insulation (1) and secure with insulation tape as necessary.

NOTE**FOLLOW-ON MAINTENANCE:**

Replace dehydrator (para 5.15).

Leak check (para 5.11), evacuate (para 5.12), and charge (para 5.13) the refrigeration system.

Close right side door.

5.25 SOLENOID VALVE (LIQUID LINE) REPAIR AND REPLACEMENT.

This task covers:

a. Removal

b. Installation

INITIAL SETUPMaterials/Parts:

Marker tags (2)
7, Appendix E
Lock Washers (2)
3, Appendix G

Equipment Conditions:

Refrigeration system discharged (para 5.8).
Left side door open.

NOTE

Repair is limited to the solenoid valve only. Replacement will include a new solenoid valve and new solenoid coil.

a. Removal.

- (1) Tag and disconnect wire leads (1).

NOTE

Solenoid coil mounting hardware is supplied with solenoid valve.

- (2) Remove screw (2), lock washer (3), data plate (4), and solenoid coil (5).
(3) Loosen two flare nuts (6).

NOTE

Note flow direction prior to removal.

- (4) Remove two bolts (7), lock washers (8), and solenoid valve (9). Discard lock washers.

5.25 SOLENOID VALVE (LIQUID LINE) REPAIR AND REPLACEMENT. - Continued

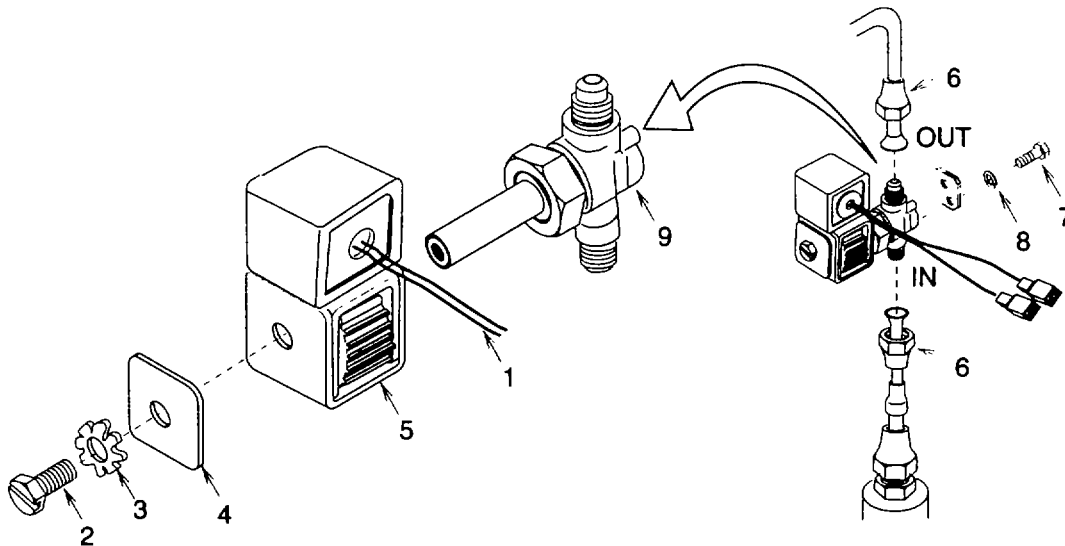

Figure 5-20. Solenoid Valve (Liquid Line)

b. Installation.

NOTE

Be sure to observe flow direction noted during removal.

- (1) Install solenoid valve (9), two new lock washers (8), and bolts (7).
- (2) Tighten two flare nuts (6).
- (3) Install solenoid coil (5), data plate (4), lock washer (3), and screw (2).
- (4) Using tags and wiring diagram (fig. 1-4), connect wire leads (1). Remove tags.

NOTE

FOLLOW-ON MAINTENANCE:
 Replace dehydrator (para 5.15).

Leak check (para 5.11), evacuate (para 5.12), and charge (para 5.13) the refrigeration system.
 Close left side door.

5.26 SOLENOID VALVE (DEFROST LINE) REPAIR AND REPLACEMENT.

This task covers:

- a. Removal
- b. Installation

INITIAL SETUP

Materials/Parts:

Marker tags (2)
7, Appendix E
Lock Washers (2)
3, Appendix G

Equipment Conditions:

Refrigeration system discharged (para 5.8).
Right side door open.

NOTE

Repair is limited to the solenoid valve only. Replacement will include a new solenoid valve and new solenoid coil.

a. Removal.

- (1) Tag and disconnect wire leads (1).

NOTE

Solenoid coil mounting hardware is supplied with solenoid valve.

- (2) Remove screw (2), lock washer (3), data plate (4), and solenoid coil (5).
- (3) Loosen two flare nuts (6).

NOTE

Note flow direction prior to removal.

- (4) Remove two bolts (7), lock washers (8), and solenoid valve (9). Discard lock washers.

5.26 SOLENOID VALVE (DEFROST LINE) REPAIR AND REPLACEMENT. - Continued

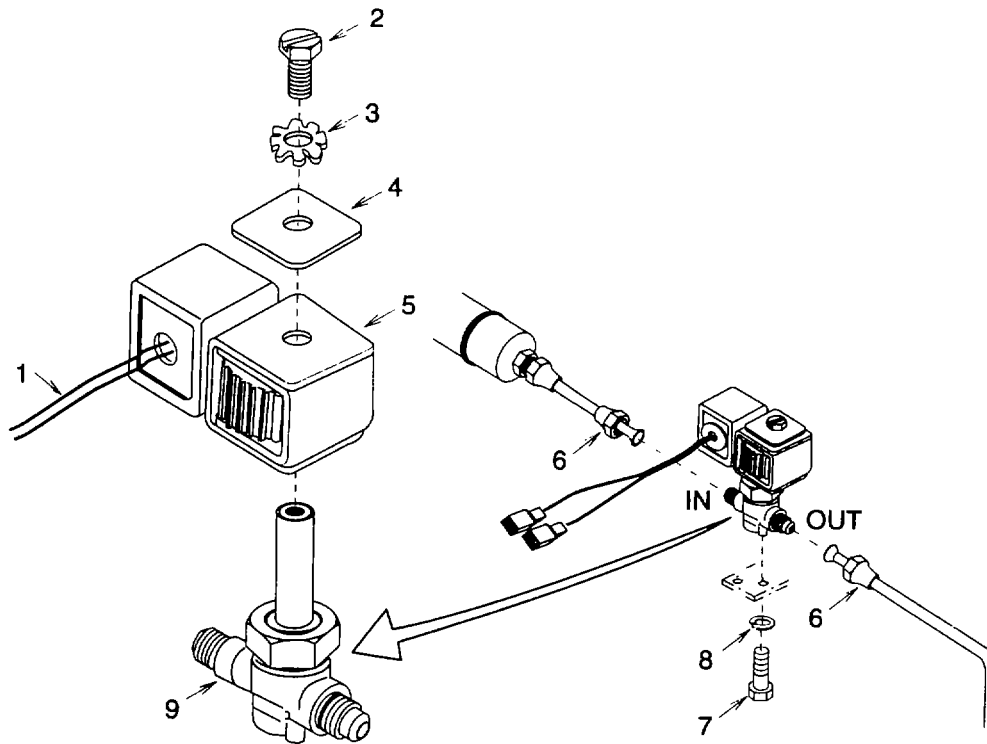

Figure 5-21. Solenoid Valve (Defrost Line)

b. Installation.

NOTE

Be sure to observe flow direction noted during removal.

- (1) Install solenoid valve (9), two new lock washers (8), and bolts (7).
- (2) Tighten two flare nuts (6).
- (3) Install solenoid coil (5), data plate (4), lock washer (3), and screw (2).
- (4) Using tags and wiring diagram (fig. 1-4), connect wire leads (1). Remove tags.

NOTE

FOLLOW-ON MAINTENANCE:
 Replace dehydrator (para 5.15).
 Leak check (para 5.11), evacuate (para 5.12), and charge (para 5.13) the refrigeration system.
 Close right side door.

5.27 STOP VALVE (LIQUID LINE) REPLACEMENT.

This task covers:

- a. Removal b. Installation

INITIAL SETUP

Materials/Parts:

Lock Washers (2)
1, Appendix G
Left side door open.

Equipment Conditions:

Refrigeration system discharged (para 5.8) and
purged (para 5.9).

a. Removal.

- (1) Remove two bolts (1) and lock washers (2). Discard lock washers.
- (2) De-braze two fittings (3) and remove stop valve (4) (para 5.10).

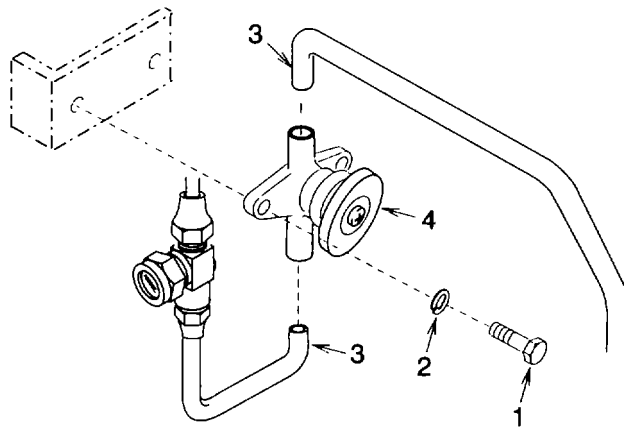

Figure 5-22. Stop Valve (Liquid Line)

b. Installation.

CAUTION

Damage to valve can occur if not disassembled prior to installation.

- (1) Install stop valve (4) and braze two fittings (3) (para 5.10).
- (2) Install two new lock washers (2) and bolts (1).

NOTE

FOLLOW-ON MAINTENANCE:

Replace dehydrator (para 5.15).

Leak check (para 5.11), evacuate (para 5.12), and charge (para 5.13) the refrigeration system.
Close left side door.

5.28 STOP VALVE (DEFROST LINE) REPLACEMENT.

This task covers:

- a. Removal
- b. Installation

INITIAL SETUP

Materials/Parts:

- Lock Washers (2)
1, Appendix G
- Insulation Tape
10, Appendix E

Equipment Conditions:

- Refrigeration system discharged (para 5.8) and
purged (para 5.9).
- Left side door open.

a. Removal.

- (1) Remove insulation (1) as necessary.
- (2) Remove two bolts (2) and lock washers (3). Discard lock washers.
- (3) De-braze two fittings (4) and remove stop valve (5) (para 5.10).

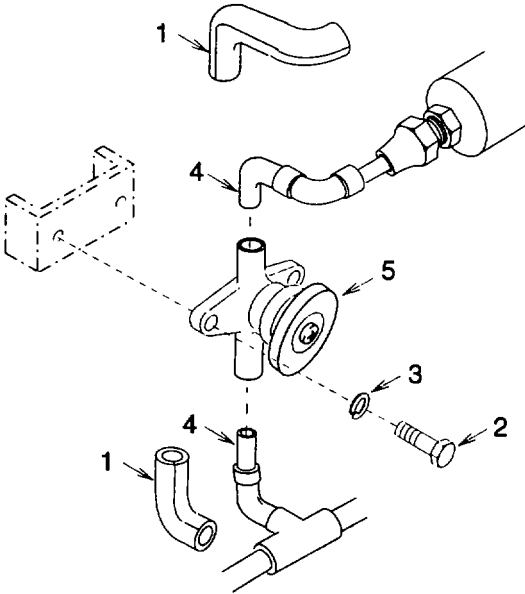

Figure 5-23. Stop Valve (Defrost Line)

b. Installation.**CAUTION**

Damage to valve can occur if not disassembled prior to installation.

- (1) Install stop valve (5) and braze two fittings (4) (para 5.10).
- (2) Install two new lock washers (3) and bolts (2).
- (3) Install insulation (1) and secure with insulation tape as necessary.

NOTE**FOLLOW-ON MAINTENANCE:**

Replace dehydrator (para 5.15).

Leak check (para 5.11), evacuate (para 5.12), and charge (para 5.13) the refrigeration system.

Close left side door.

5.29 SIGHT INDICATOR REPLACEMENT.

This task covers:

a. Removal

b. Installation

INITIAL SETUP**Materials/Parts:**

Self Locking Nut
12, Appendix G

Equipment Conditions:

Refrigeration system discharged (para 5.8).
Left side door open.

a. Removal.

- (1) Remove self locking nut (1), bolt (2), and spacer (3). Do not remove clamp (4).
- (2) Loosen two flare nuts (5) and remove sight indicator (6).

b. Installation.

- (1) Install sight indicator (6), aligned facing out, and tighten two flare nuts (5).
- (2) Aline clamp (4) and install bolt (2), spacer (3), and new self locking nut (1).

5.29 SIGHT INDICATOR REPLACEMENT. - Continued

Figure 5-24. Sight Indicator

NOTE

FOLLOW-ON MAINTENANCE:

Replace dehydrator (para 5.15).

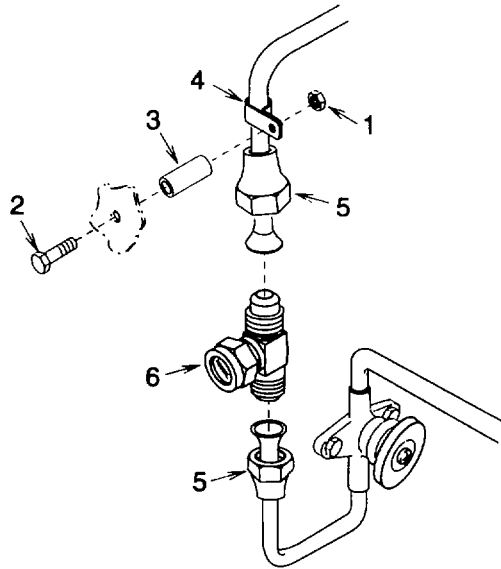
Leak check (para 5.11), evacuate (para 5.12), and charge (para 5.13) the refrigeration system.

Close left side door.

5.30 CONDENSER COIL REPLACEMENT. - Continued

Figure 5-25. Condenser Coil

b. Installation.

(1) If condenser fan shroud (6) was removed, install per the following:

- (a) Carefully install condenser fan shroud (6).
- (b) Install four flat washers (16) and bolts (15).
- (c) Aline discharge tube brackets (17) and install eight new lock washers (14) and bolts (13).
- (d) Install filter-drier base support (12), four new lock washers (11), and bolts (10).
- (e) Install solenoid valve bracket (9), two new lock washers (8), and bolts (7).
- (f) Install solenoid valve (liquid line) (para 5.25).
- (g) Install condenser fan (para 4.36).

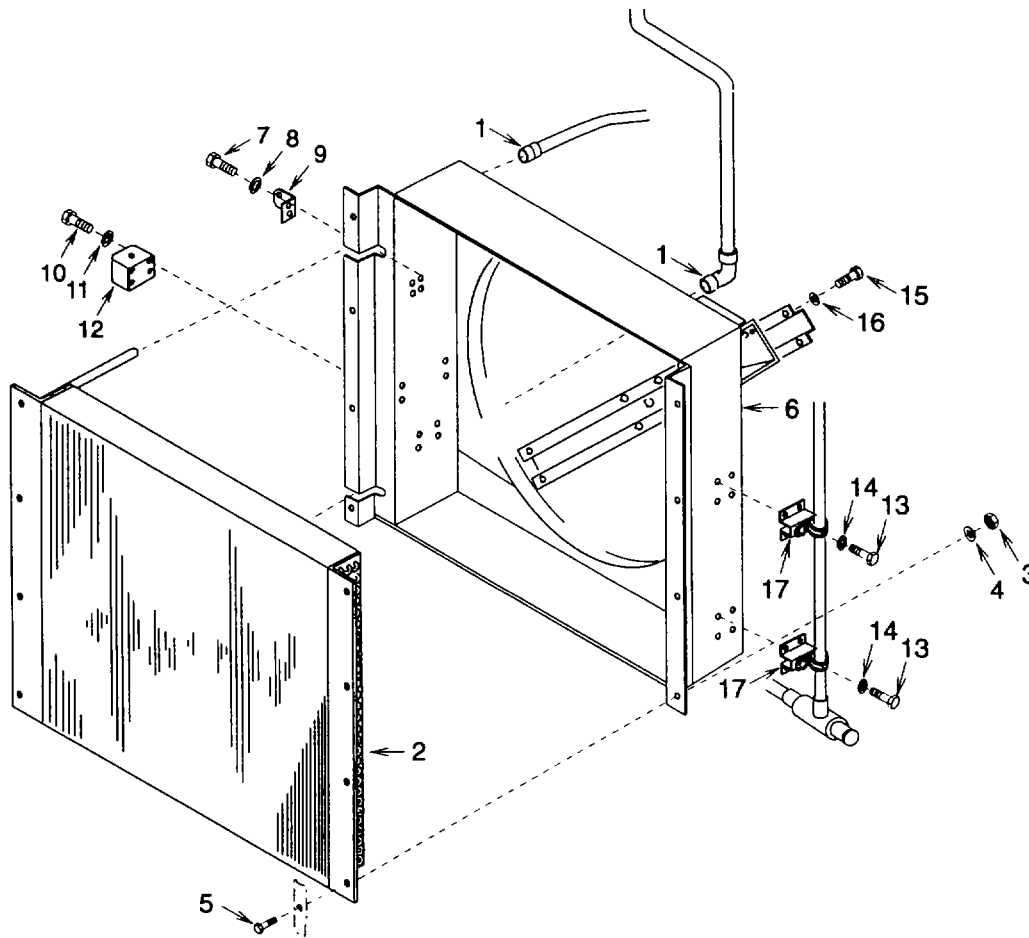
WARNING

Coil fins are sharp and can cut hands or fingers. Wear gloves to prevent personal injury when handling coil.

- (2) Install condenser coil (2), eight bolts (5), flat washers (4), and new self locking nuts (3).
- (3) Braze two fittings (1) onto condenser coil (2) (para 5.10).

NOTE

FOLLOW-ON MAINTENANCE:
Install condenser coil guard (para 4.17).
Replace dehydrator (para 5.15).
Leak check (para 5.11), evacuate (para 5.12), and charge (para 5.13) the refrigeration system.
Close both side doors.

5.31 TUBING AND FITTINGS TESTING. REPAIR. AND REPLACEMENT

This task covers:

- | | | |
|-------------------|-------------------|------------------------|
| a. Testing | b. Removal | c. Installation |
|-------------------|-------------------|------------------------|

INITIAL SETUP

Materials/Parts:

- Silicone RTV
20, Appendix E
- Insulation Tape
10, Appendix E

Equipment Conditions:

Doors, panels, guard open/removed as necessary.

General Safety Instructions:

WARNING

High voltage and rotating parts are used in the refrigeration unit. Personal injury can result if power is connected.

- a. Testing. Leak test the tubing and fittings (para 5.11).

NOTE

Repair consists of replacing damaged or leaking tubing and/or fittings.

- b. Removal.

- (1) Discharge (para 5.8) the refrigeration system.
- (2) If a flare connection was leaking, loosen flare nut and cut the damaged flare off the tubing end.
- (3) Remove insulation as necessary.
- (4) Purge (para 5.9) the refrigeration system and de-braze (para 5.10) any fitting or tubing that was leaking or was too short to flare.

5.31 TUBING AND FITTINGS TESTING, REPAIR, AND REPLACEMENT. - Continued

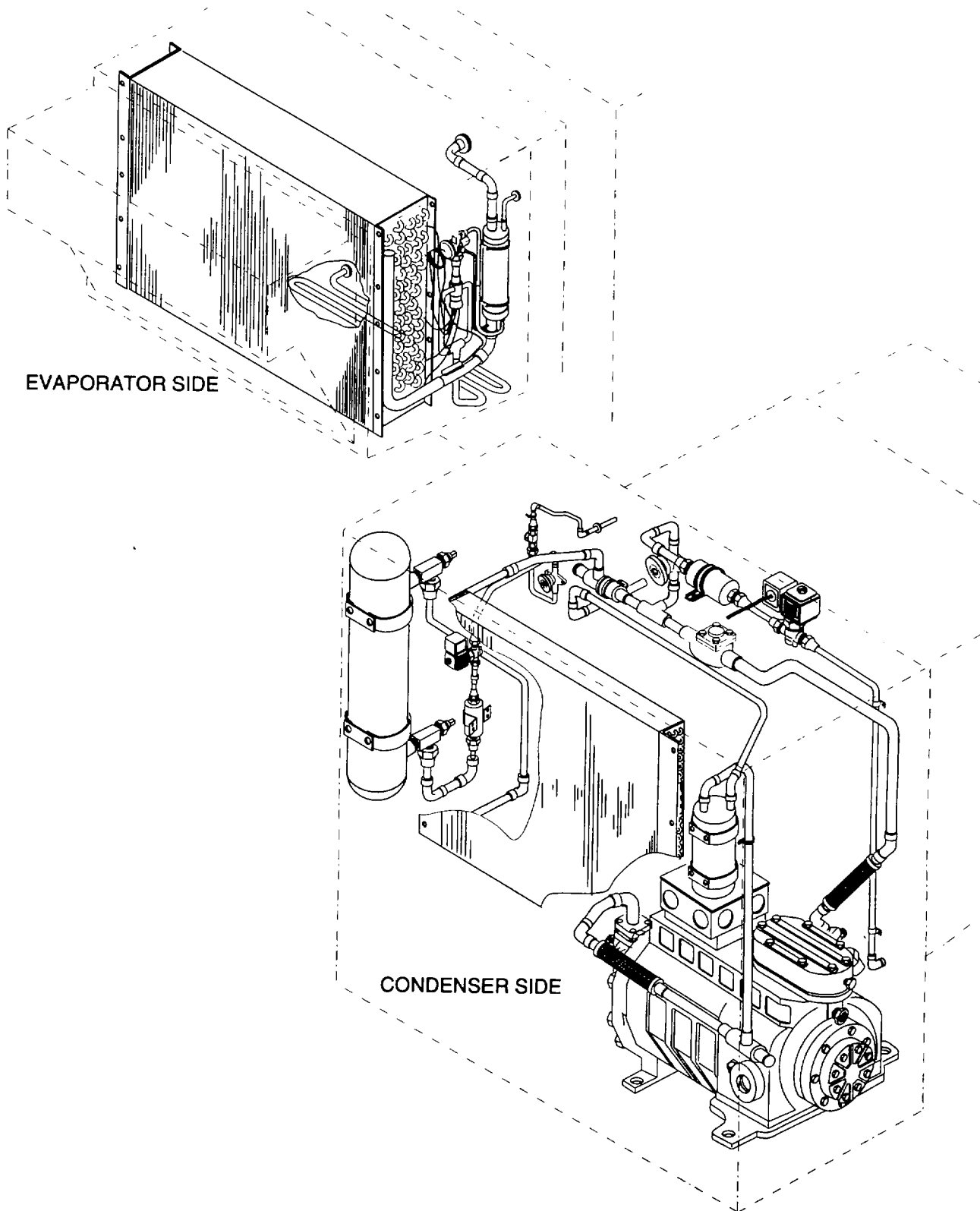

Figure 5-26. Tubing And Fittings

(5) Remove any silicone RTV remaining in evaporator frame grommets.

c. Installation.

- (1) Purge (para 5.9) the refrigeration system and braze (para 5.10) any loose tubing or fitting connections.
- (2) Flare tubing end where damaged flare was removed or on end of new tube if it was too short to flare.
- (3) Replace dehydrator (para 5.15).
- (4) Leak check (para 5.11), evacuate (para 5.12), and charge (para 5.13) the refrigeration system.
- (5) Apply silicone RTV into evaporator frame grommets to seal evaporator enclosure.
- (6) Install insulation if removed and secure with insulation tape as necessary.

NOTE

FOLLOW-ON MAINTENANCE:

Close/install any doors, panels, guard removed.

5.32 DIFFERENTIAL OIL PRESSURE SWITCH S5 REPLACEMENT.

This task covers:

a. Removal

b. Installation

INITIAL SETUP

Materials/Parts:

- Lock Washers (2) (Pressure Switch)
1, Appendix G
- Lock Washer (Clamp)
1, Appendix G
- Tie Down Straps
24, Appendix E
- Marker tags (4)
7, Appendix E

Equipment Conditions:

- Refrigeration system discharged (para 5.8).
 - Right side door open.
-

a. Removal.

- (1) Loosen screw (1) and remove cover (2).
- (2) Tag wire leads (3). Remove four screws (4) and pull leads out of differential oil pressure switch (5).
- (3) Remove bolt (6), lock washer (7), and clamp (8). Discard lock washer.
- (4) Remove tie down straps (9) as necessary.
- (5) Tag each capillary tube (10) and loosen two flare nuts (11) from tee (12) and elbow (13).

5.32 DIFFERENTIAL OIL PRESSURE SWITCH S5 REPLACEMENT. - Continued

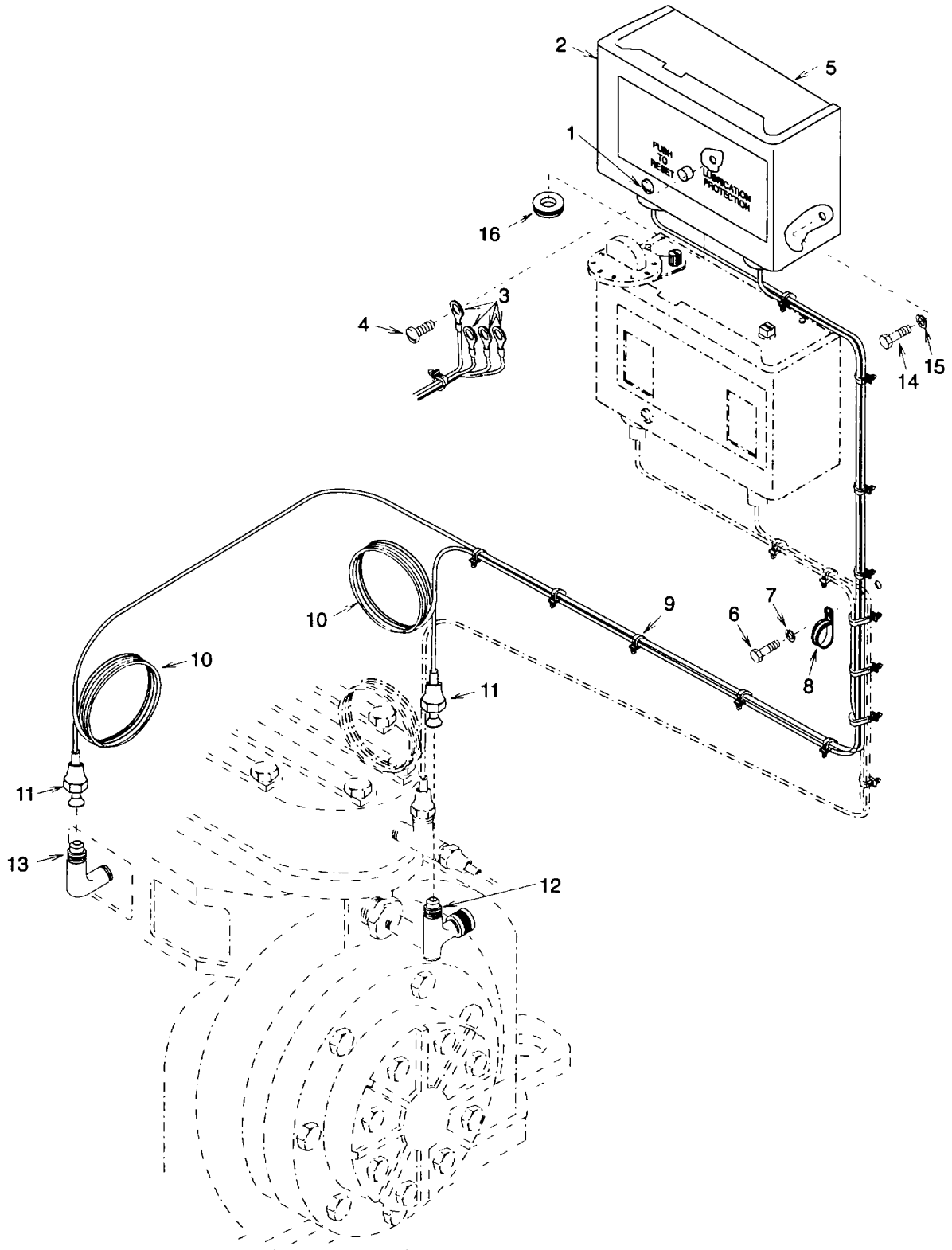

- (6) Remove two bolts (14), lock washers (15), and differential oil pressure switch (5).
- (7) Remove grommet (16).

b Installation

- (1) Loosen screw (1) and remove cover (2) from new differential oil pressure switch (5).
- (2) Remove and discard metal jumper from between terminals M and 2.
- (3) Install grommet (16).
- (4) Install differential oil pressure switch (5), two new lock washers (15), and bolts (14).
- (5) Using tags on old differential pressure switch (5) for reference, neatly route new capillary tubing (10) to tee (1) and elbow (13). Carefully coil excess tubing as necessary.
- (6) Aline each capillary tube (10) to tee (12) and elbow (13). Tighten two flare nuts (11).
- (7) Install new tie down straps (9) as necessary.
- (8) Install clamp (8) around capillary tubes (10). Install new lock washer (7) and bolt (6).
- (9) Push four wire leads (3) into differential oil pressure switch (5) and using tags and wiring diagram (fig. 1-4), install wire leads and screws (4). Remove tags.
- (10) Install cover (2) and tighten screw (1).

NOTE

FOLLOW-ON MAINTENANCE:

Replace dehydrator (para 5.15).

Leak check (para 5.11), evacuate (para 5.12), and charge (para 5.13) the refrigeration system.

Close right side door.

5.33 DUAL PRESSURE CONTROL SWITCH S2 REPLACEMENT.

This task covers:**a. Removal****b. Installation****INITIAL SETUP**Materials/Parts:

Lock Washers (2) (Pressure Switch)
1, Appendix G
Lock Washer (Clamp)
1, Appendix G
Tie Down Straps
24, Appendix E
Marker tags (4)
7, Appendix E

Equipment Conditions:

Refrigeration system discharged (para 5.8).
Right side door open.

a. Removal.

- (1) Loosen screw (1) and remove cover (2).
- (2) Tag wire leads (3). Remove two screws (4) and pull leads out of dual pressure control switch (5).
- (3) Remove bolt (6), lock washer (7), and clamp (8). Discard lock washer.
- (4) Remove tie down straps (9) as necessary.
- (5) Tag each capillary tube (10) and loosen two flare nuts (11) from tees (12).
- (6) Remove two bolts (13), lock washers (14), and differential oil pressure switch (5).
- (7) Remove grommet (15).

b. Installation.

- (1) Loosen screw (1) and remove cover (2) from new dual pressure control switch (5).
- (2) Install grommet (15).
- (3) Install dual pressure control switch (5), two new lock washers (14), and bolts (13).
- (4) Using tags on old dual pressure control switch (5) for reference, neatly route new capillary tubing (10) to tees (12) and carefully coil excess tubing as necessary.
- (5) Aline each capillary tube (10) to tee (12) and tighten two flare nuts (11).
- (6) Install new tie down straps (9) as necessary.
- (7) Install clamp (8) around capillary tubes (10). Install new lock washer (7) and bolt (6).

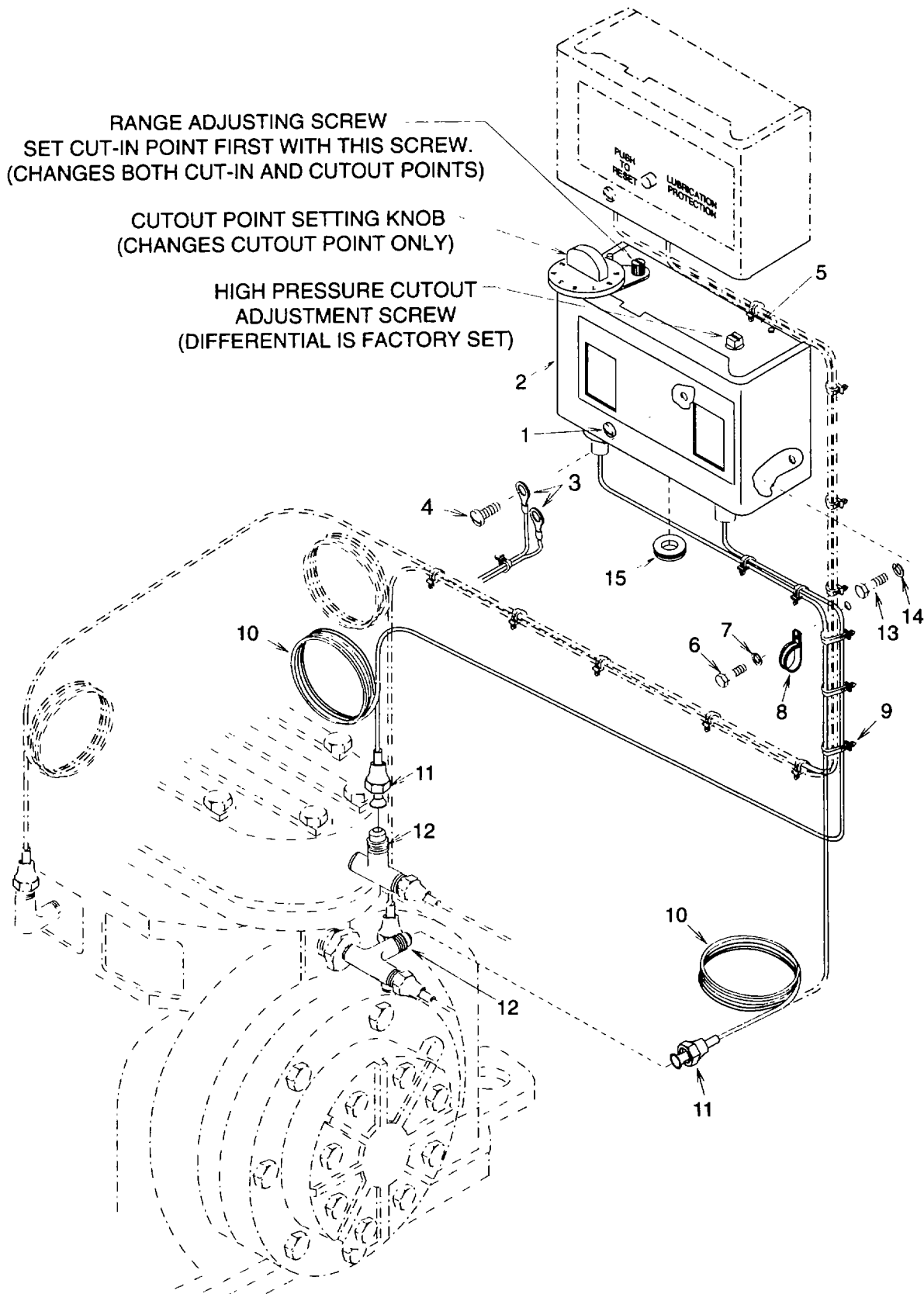

Figure 5-28. Dual Pressure Control Switch

5.33 DUAL PRESSURE CONTROL SWITCH S2 REPLACEMENT. - Continued

- (8) Push two wire leads (3) into dual pressure control switch (5) and using tags and wiring diagram (fig. 1-4), install wire leads and screws (4). Remove tags.
- (9) Install cover (2) and tighten screw (1).
- (10) Adjust HIGH PRESSURE CUTOFF to 305, low pressure CUT IN to 0, and low pressure CUTOFF to 15 IN. VAC.

NOTE**FOLLOW-ON MAINTENANCE:**

Replace dehydrator (para 5.15).

Leak check (para 5.11), evacuate (para 5.12), and charge (para 5.13) the refrigeration system.

Close right side door.

5.34 PRESSURE GAGE (LOW) REPLACEMENT.

This task covers:**a. Removal****b. Installation****INITIAL SETUP**Materials/Parts:

Lock Washers (3)
6, Appendix G
Anti-Seize Tape
22, Appendix E

Equipment Conditions:

Refrigeration system discharged (para 5.8).
Left side door open.

a. Removal.

- (1) Remove three bolts (1), lock washers (2), and pressure gage (3) as far as copper tubing (4) will allow. Discard lock washers.
- (2) Loosen flare nut (4) and move copper tubing (4) over to one side being careful not to bend or kink tubing.
- (3) Remove coupling (6).

b. Installation.

- (1) Wrap anti-seize tape around pressure gage (3) connector threads.
- (2) Install coupling (6).
- (3) Aline copper tubing (4) and connect flare nut (5) to coupling (6).
- (4) Install pressure gage (3), three new lock washers (2), and bolts (1).

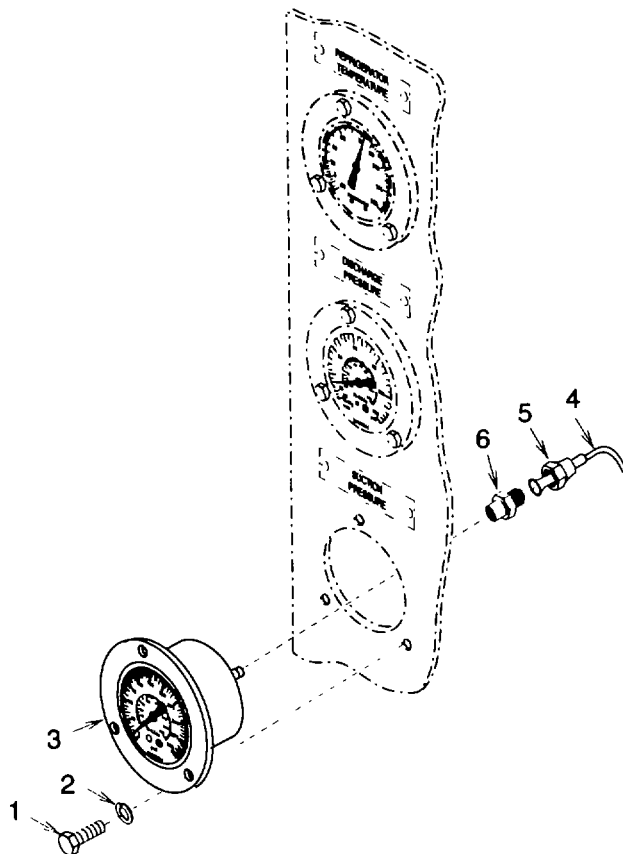

Figure 5-29. Pressure Gage (Low)

NOTE

FOLLOW-ON MAINTENANCE:

Replace dehydrator (para 5.15).

Leak check (para 5.11), evacuate (para 5.12), and charge (para 5.13) the refrigeration system.

Close left side door.

5.35 PRESSURE GAGE (HIGH) REPLACEMENT.

This task covers:

a. Removal

b. Installation

INITIAL SETUP

Materials/Parts:

Lock Washers (3)
6, Appendix G
Anti-Seize Tape
22, Appendix E

Equipment Conditions:

Refrigeration system discharged (para 5.8).
Left side door open.

a. Removal.

- (1) Remove three bolts (1), lock washers (2), and pressure gage (3) as far as copper tubing (4) will allow. Discard lock washers.
- (2) Loosen flare nut (5) and move copper tubing (4) over to one side being careful not to bend or kink tubing.
- (3) Remove coupling (6).

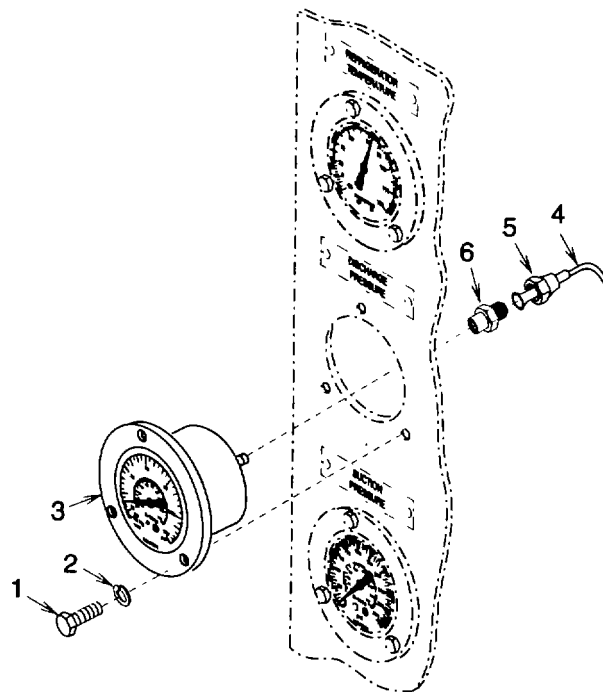

Figure 5-30. Pressure Gage (High)

b. Installation.

- (1) Wrap anti-seize tape around pressure gage (3) connector threads.
- (2) Install coupling (6).
- (3) Aline copper tubing (4) and connect flare nut (5) to coupling (6).
- (4) Install pressure gage (3), three new lock washers (2), and bolts (1).

NOTE

FOLLOW-ON MAINTENANCE:

Replace dehydrator (para 5.15).

Leak check (para 5.11), evacuate (para 5.12), and charge (para 5.13) the refrigeration system.

Close left side door.

5.36 HEAT EXCHANGER REPLACEMENT.

This task covers:

a. Removal

b. Installation

INITIAL SETUP

Materials/ Parts:

Insulation Tape
10, Appendix E

Equipment Conditions:

Refrigeration system discharged (para 5.8) and
purged (para 5.9).
Right side panel removed (para 4.16).

a. Removal.

- (1) Remove insulation (1) as necessary.
- (2) De-braze five fittings (2) from heat exchanger (3) (para 5.10).
- (3) Loosen or remove two hose clamps (4) and remove heat exchanger (3).

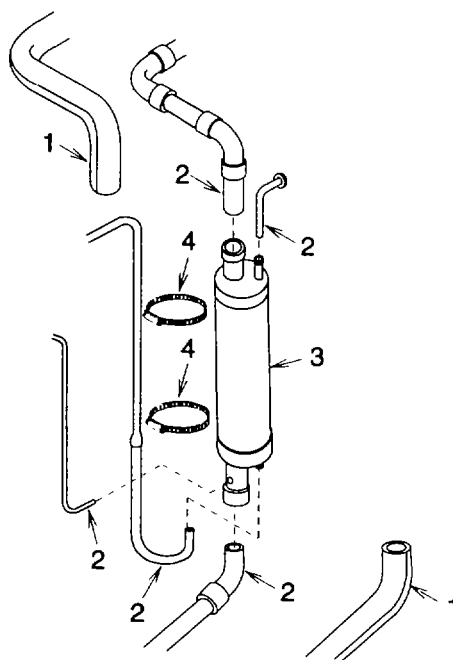

Figure 5-31. Heat Exchanger

b. Installation.

- (1) Install heat exchanger (3) into two hose clamps (4). Tighten hose clamps.
- (2) Braze five fittings (2) onto heat exchanger (3) (para 5.10).
- (3) Install insulation (1) and secure with insulation tape as necessary.

NOTE

FOLLOW-ON MAINTENANCE:

Replace dehydrator (para 5.15).

Leak check (para 5.11), evacuate (para 5.12), and charge (para 5.13) the refrigeration system.

Install right side panel (para 4.16).

5.37 EXPANSION VALVE REPLACEMENT.

This task covers:**a. Removal****b. Installation****INITIAL SETUP**Materials/Parts:

Lock Washer
1, Appendix G
Insulation Tape
10, Appendix E
Tie Down Strap
24, Appendix E

Equipment Conditions:

Refrigeration system discharged (para 5.8).
Right side panel removed (para 4.16).

a. Removal.

- (1) Remove insulation (1) as necessary.
- (2) Remove and discard tie down strap (2).
- (3) Loosen three flare nuts (3).
- (4) Remove bolt (4), lock washer (5), flat washer (6), expansion valve (7), and clamp (8). Discard lock washer.

b. Installation.

- (1) Install clamp (8), expansion valve (7), flat washer (6), new lock washer (5), and bolt (4).
- (2) Tighten three flare nuts (3).
- (3) Install sensing bulb (9) and secure with new tie down strap (2).
- (4) Install insulation (1) and secure with insulation tape as necessary.

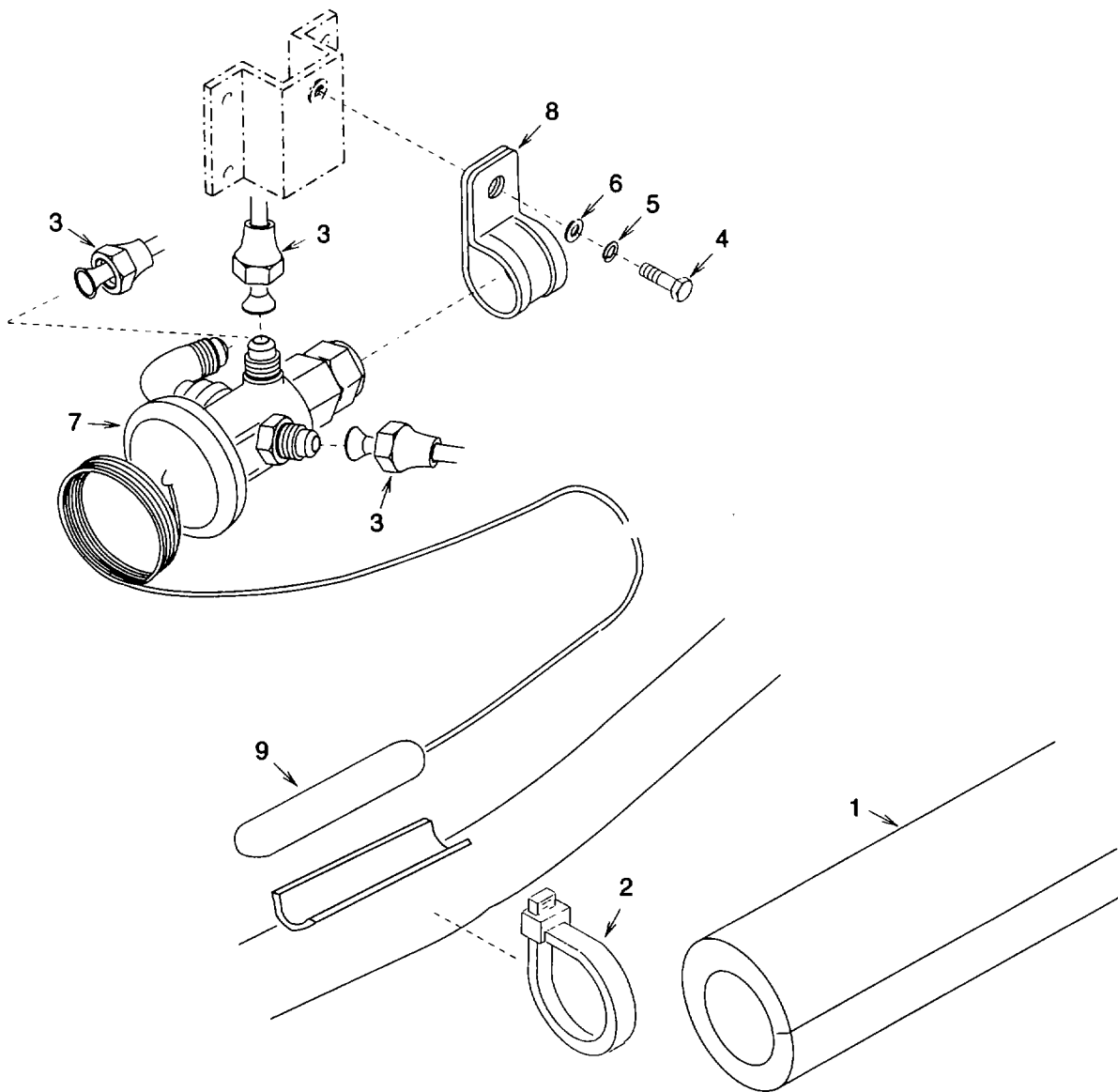

Figure 5-32. Expansion Valve

NOTE

FOLLOW-ON MAINTENANCE:
 Replace dehydrator (para 5.15).
 Leak check (para 5.11), evacuate (para 5.12), and charge (para 5.13) the refrigeration system.
 Install right side panel (para 4.16).

5.38 EVAPORATOR COIL REPLACEMENT.

This task covers:**a. Removal****b. Installation****INITIAL SETUP**Materials/Parts:

Lock Washers (17)
 3, Appendix G
 Lock Washer
 1, Appendix G
 Marker Tags (3)
 7, Appendix E
 Expansion valve removed (para 5.37).

Equipment Conditions:

Top panel removed (para 4.15).
 Side panels removed (para 4.16).
 V-Belt removed (para 4.31).
 Refrigeration system discharged (para 5.8) and
 purged (para 5.9).
 Temperature switch removed (para 4.43).

a. Removal.

- (1) Tag and disconnect wire leads (1).
- (2) Remove 17 bolts (2), lock washers (3), flat washers (4), and shroud (5). Discard lock washers.
- (3) Remove bolt (6), lock washer (7), and flat washer (8). Do not remove clamps (9) from sensing bulbs (10).
 Discard lock washer.
- (4) Remove 10 bolts (11) and flat washers (12).
- (5) Carefully slide evaporator fan and shaft (13) enough to allow removal of evaporator fan shroud (14).

WARNING

Coil fins are sharp and can cut hands or fingers. Wear gloves to prevent personal injury when handling coil.

- (6) De-braze three fittings (15) from evaporator coil (16) (para 5.10) and remove evaporator coil.
- (7) Remove ten bolts (17), flat washers (18), and evaporator fan shroud (14).

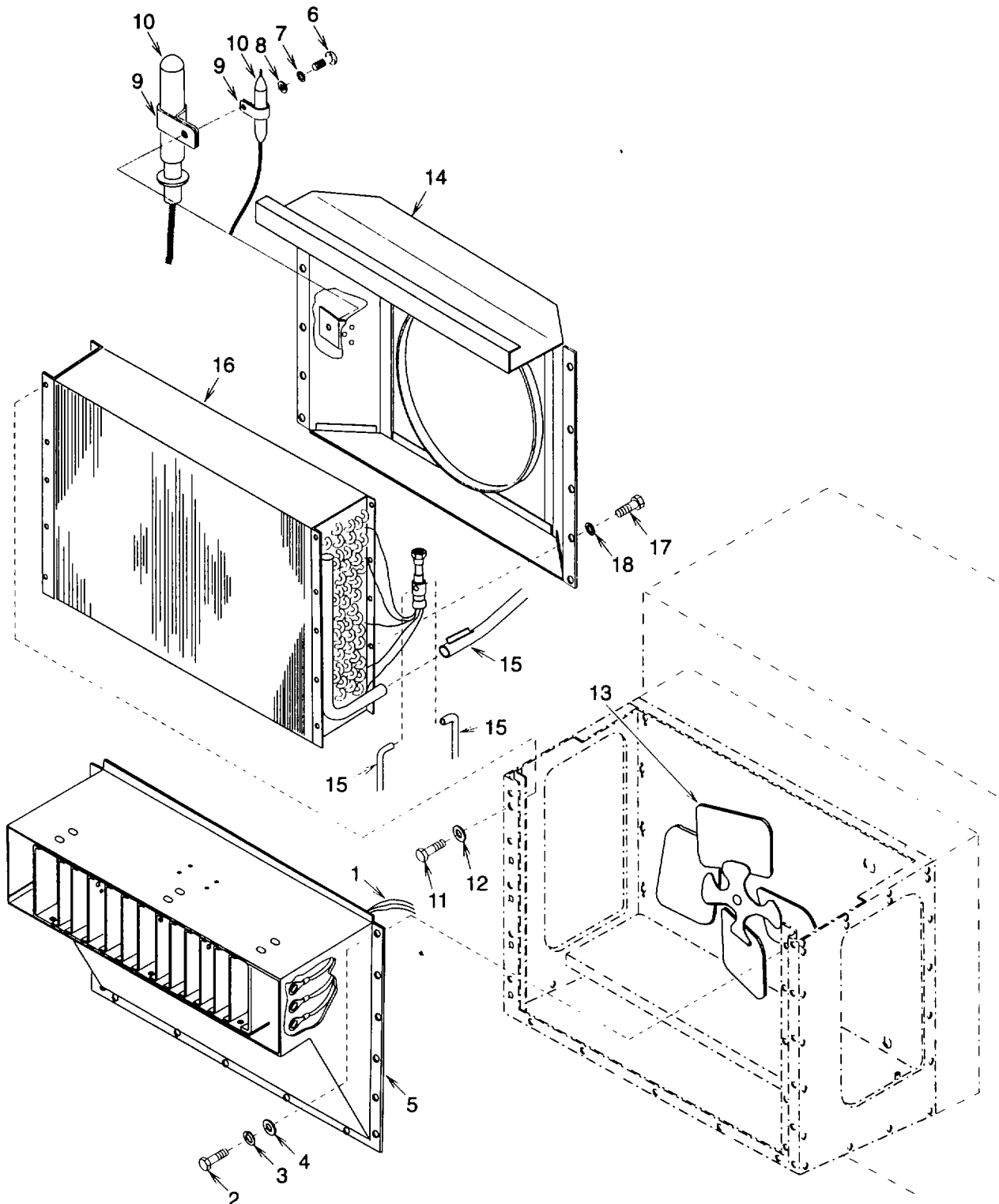

Figure 5-33. Evaporator Coil

5.38 EVAPORATOR COIL REPLACEMENT. - Continued

b. Installation.

- (1) Install evaporator fan shroud (14), ten flat washers (18), and bolts (17).

WARNING

Coil fins are sharp and can cut hands or fingers. Wear gloves to prevent personal injury when handling coil.

- (2) Install evaporator coil (16) and braze three fittings (15) onto evaporator coil (para 5.10).
- (3) Install 10 flat washers (12) and bolts (11).
- (4) Be sure sensing bulbs (10) are in clamps (9) then align clamps and install flat washer (8), new lock washer (7), and bolt (6).
- (5) Align shroud (5) and install 17 flat washers (4), new lock washers (3), and bolts (2).
- (6) Using tags and wiring diagram (fig. 1-4), install wire leads (1). Remove tags.

NOTE**FOLLOW-ON MAINTENANCE:**

Install temperature switch (para 4.43).

Install expansion valve (para 5.37).

Install top panel (para 4.15).

Install side panels (para 4.16).

Install and adjust V-belt (para 4.31).

Replace dehydrator (para 5.15).

Leak check (para 5.11), evacuate (para 5.12), and charge (para 5.13) the refrigeration system.

5.39 COMPRESSOR B1 SERVICE. TESTING, REPAIR. AND REPLACEMENT.

This task covers:

- | | | |
|-----------------------|--------------------|------------------------|
| a. Service | b. Testing | c. Removal |
| d. Disassembly | e. Assembly | f. Installation |

INITIAL SETUP

Materials/Parts:

- Lock Washers (4)
18, Appendix G
- Locknut (4)
19, Appendix G
- Service Valve Gasket (Suction)
20, Appendix G
- Service Valve Gasket (Discharge)
21, Appendix G
- Cylinder Head Gasket
22, Appendix G
- Valve Plate Gasket

23, Appendix G
- Sight Glass
24, Appendix G
- Lock Washers (2)

25, Appendix G
- Fused Cluster Terminal
26, Appendix G
- Fused Cluster Seal
27, Appendix G
- Terminal Mounting Plate Gasket
9, Appendix G

Materials/Parts:

- Oil Pump Gasket
10, Appendix G
- Seal
2, Appendix G
- Marker tags (15)
7, Appendix E
- Anti-Seize Tape
22, Appendix E
- Lubricating Oil
21, Appendix E

Equipment Conditions:

- Front door open.
- Both side doors open.

General Safety Instructions:

WARNING

Compressor lubricating oil is caustic. Wear gloves and a face protector or safety glasses in any situation where skin or eye contact is possible. If oil does contact skin, wash with soap and water.

a. Service.

- (1) Check oil level through sight glass (1). If oil level is not within best operating range, discharge refrigeration system (para 5.8).

CAUTION

Use only specified oil. Compressor damage can result.

NOTE

The oil fill plug cannot be purchased separately from the compressor. Care must be taken so it does not get lost or damaged.

- (2) Remove oil fill plug (2) then add or remove lubricating oil as necessary.
- (3) Wrap anti-seize tape around oil fill plug (2) threads and install oil fill plug.

5.39 COMPRESSOR B1 SERVICE, TESTING, REPAIR, AND REPLACEMENT. - Continued

- (4) Replace dehydrator (para 5.15).
- (5) Leak check (para 5.11), evacuate (para 5.12), and charge (para 5.13) the refrigeration system.

b. Testing.

- (1) Remove two screws (3) and cover (4).
- (2) Using multimeter set to measure continuity, check compressor (5) winding continuity between terminals 1 to 2, 1 to 3, and 3 to 2. Continuity should be indicated. If continuity was not indicated, replace compressor.
- (3) Using multimeter set to measure continuity, check compressor (5) winding continuity between each terminal 1, 2, and 3 to compressor frame ground. No continuity should be indicated. If continuity was indicated, replace compressor.
- (4) Discharge refrigeration system (para 5.8).
- (5) Remove eight screws (6), cylinder head (7), cylinder head gasket (8), valve plate assembly (9), two reed valves (10), and valve plate gasket (11). Discard gaskets.
- (6) Examine reed valves (10) for warpage and any other physical damage. Replace valve plate assembly (9) if reed valves are damaged.
- (7) Examine compressor (5) cylinder walls for any scoring or excessive wear (groove at top of piston (12) travel. Replace compressor if scored or excessively worn.
- (8) Press on top of highest piston (12). When pushed down, the higher piston should have some resistance and the lower piston should rise. Repeat for other piston. If either piston was loose and did not cause the other one to rise, replace piston and any other damaged components.
- (9) If no failure was indicated, remove any gasket material from all machined gasket surfaces and install new valve plate gasket (11), two reed valves (10), valve plate assembly (9), new cylinder head gasket (8), cylinder head (7), and eight screws (6).
- (10) Install cover (4) and two screws (3).
- (11) Replace dehydrator (para 5.15).
- (12) Leak check (para 5.11), evacuate (para 5.12), and charge (para 5.13) the refrigeration system.

c. Removal.**NOTE**

Remove only items necessary to access defective component(s).

- (1) Remove two screws (3) and cover (4).
- (2) Tag wire leads (13). Remove four screws (14) and pull wire leads out through strain relief cable bushing (15).
- (3) Remove conduit locknut (16) and strain relief cable bushing (15).

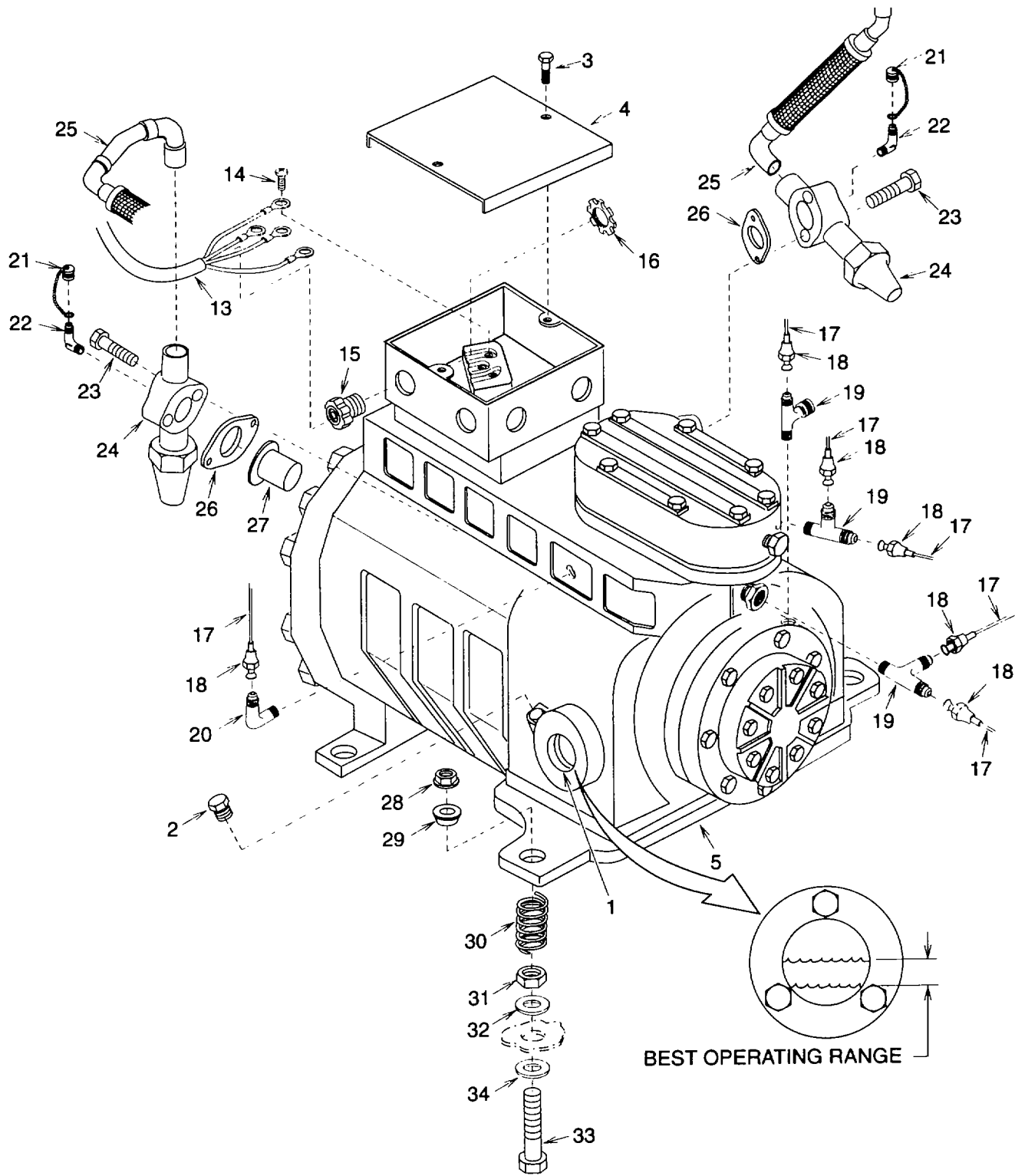

Figure 5-34. Compressor (Sheet 1 of 2)

5.39 COMPRESSOR B1 SERVICE, TESTING, REPAIR, AND REPLACEMENT. - Continued

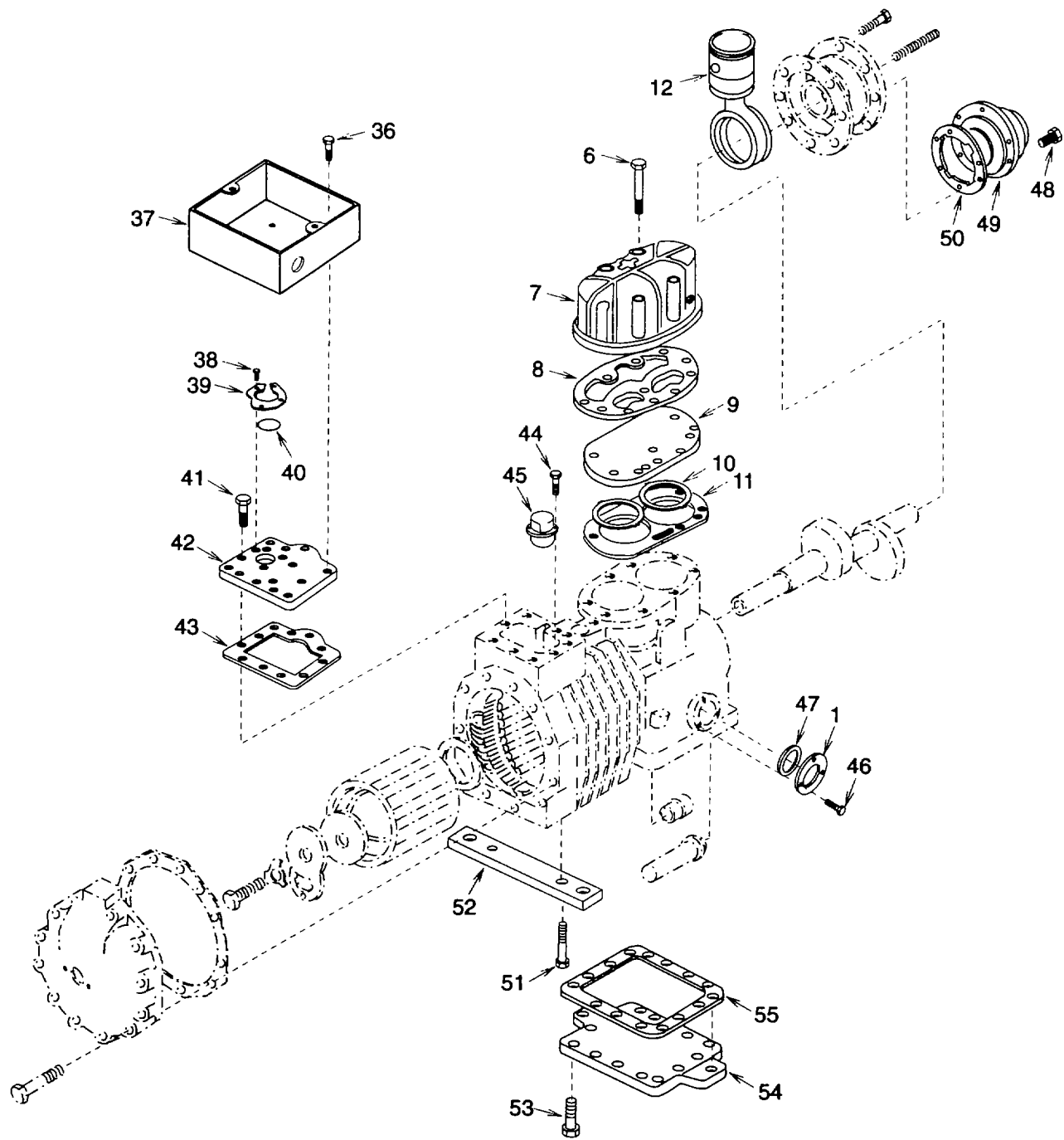

Figure 5-34. Compressor (Sheet 2 of 2)

- (4) Discharge refrigeration system (para 5.8).
- (5) Tag capillary tubes (17) and loosen five flare nuts (18) from tees (19) and flare nut from elbow (20). Carefully pull tubes away from tees and elbow being careful not to bend or kink tubes.
- (6) Remove three tees (19) and elbow (20).
- (7) Remove two caps and chains (21) and elbows (22).
- (8) Remove four screws (23). Pull two service valves (24) away from compressor (5) being careful not to bend or kink tubing (25). Remove two service valve gaskets (26) and suction screen (27). Discard gaskets.

WARNING

Compressor weight exceeds 290 lb (132 kg). Use appropriate lifting device to avoid personal injury.

- (9) Remove four locknuts (28), mounting spacers (29), and compressor (5). Discard locknuts.
- (10) Remove four mounting springs (30).
- (11) Remove four nuts (31), flat washers (32), screws (33), lock washers (34), and flat washers (35). Discard lock washers.
- (12) De-braze two service valves (24) from tubing (25) (para 5.10).

d. Disassembly.**NOTE****Disassemble only as necessary to replace defective component(s).**

- (1) Remove eight screws (6), cylinder head (7), cylinder head gasket (8), valve plate assembly (9), two reed valves (10), and valve plate gasket (11). Discard gaskets.
- (2) Remove four screws (36) and terminal box (37).
- (3) Remove three screws (38), fused cluster terminal (39), and fused cluster seal (40). Discard fused cluster terminal and seal.
- (4) Remove 10 screws (41), terminal plate (42), and terminal mounting plate gasket (43). Discard gasket.
- (5) Remove two screws (44) and protector (45).
- (6) Remove three screws (46), sight glass (1), and seal (47). Discard seal.
- (7) Remove six screws (48), oil pump (49), and oil pump gasket (50). Discard gasket.
- (8) Remove two screws (51), and mounting foot plate (52).
- (9) Remove 27 screws (53), bottom plate (54), and bottom plate gasket (55). Discard gasket.

5.39 COMPRESSOR B1 SERVICE, TESTING, REPAIR, AND REPLACEMENT. - Continued

e. Assembly.

- (1) Remove any gasket material from all machined gasket surfaces.
- (2) Install new bottom plate gasket (55), bottom plate (54), and 27 screws (53).
- (3) Install mounting foot plate (52), and two screws (51).
- (4) Install new oil pump gasket (50), oil pump (49), and six screws (48).
- (5) Install new seal (47), sight glass (1) and three screws (46).
- (6) Install protector (45) and two screws (44).
- (7) Install new terminal mounting plate gasket (43), terminal plate (42), and 10 screws (41).
- (8) Install new fused cluster seal (40), new fused cluster terminal (39), and three screws (38).
- (9) Install terminal box (37) and four screws (36).
- (10) Install new valve plate gasket (11), two reed valves (10), valve plate assembly (9), new cylinder head gasket (8), cylinder head (7), and eight screws (6).
- (11) Check compressor lubricating oil level at sight glass (1). Level should be at mid-point of sight glass. Add or remove oil as necessary.
 - (a) Remove plug (2).
 - (b) Add or remove oil as necessary.
 - (c) Wrap anti-seize tape around plug (2) threads.
 - (d) Install plug (2).

f. Installation.

- (1) Install two service valves (24) onto tubing (25) with mounting surfaces at right angles to each other and braze connection (para 5.10).
- (2) Install four flat washers (35), new lock washers (34), screws (33), flat washers (32), and nuts (31).
- (3) Install four mounting springs (30).

WARNING

Compressor weight exceeds 290 lb (132 kg). Use appropriate lifting device to avoid personal injury.

- (4) Install compressor (5), four mounting spacers (29), and new locknuts (28).

- (5) Install suction screen (27), two new service valve gaskets (26), service valves (24), and four screws (23).
- (6) Wrap anti-seize tape around threaded end of each elbow (22). Install two elbows and one cap and chain (21) onto each elbow.
- (7) Wrap anti-seize tape around threaded end of each tee (19) and elbow (20). Install three tees and elbow.
- (8) Aline capillary tubes (17) with tees (19) and elbow (20) using tags as reference being careful not to bend or kink tubes. Tighten six flare nuts (18).
- (9) Install strain relief cable bushing (15) and conduit locknut (16).
- (10) Push wire leads (13) through strain relief cable bushing (15). Install wire leads, using tags and wiring diagram (fig. 1-4), and four screws (14). Remove tags.
- (11) Install cover (4) and two screws (3).
- (12) Replace dehydrator (para 5.15).
- (13) Leak check (para 5.11), evacuate (para 5.12), and charge (para 5.13) the refrigeration system.

NOTE
FOLLOW-ON MAINTENANCE:
Close both side doors.
Close front door.

5.40 CONDENSER ENCLOSURE REPAIR.

This task covers:**a. Repair**

INITIAL SETUP**Equipment Conditions:**

Refrigeration unit shut down (para 2.7) and power disconnected.

General Safety Instructions:**WARNING**

High voltage and rotating parts are used in the refrigeration unit. Personal injury can result if power is connected.

Repair.

- (1) Disassemble refrigeration unit as necessary and make repairs as indicated.
- (2) Drill through rivet or blind rivet nut using drill bit slightly smaller than rivet diameter.
- (3) Remove any remaining rivet material.
- (4) Install new rivet or blind rivet nut as required.
- (5) Repair any minor sheet metal dents and bent edges by straightening using common sheet metal repair procedures.
- (6) Weld any cracks or breaks in frame members or welds per MIL-B-7883.
- (7) Touch-up any painted surfaces per TM 43-0139.
- (8) Assemble refrigeration unit as necessary to return to service.

5.41 PLATES (DATA) REPLACEMENT

This task covers:

a. Removal

b. Installation

INITIAL SETUP**Equipment Conditions:**

Refrigeration unit shut down (para 2.7) and power disconnected.

General Safety Instructions:**WARNING**

High voltage and rotating parts are used in the refrigeration unit. Personal injury can result if power is connected.

a. Removal.

- (1) Drill through rivets using drill bit slightly smaller than rivet diameter.
- (2) Remove plate and any remaining rivet material.

b. Installation. Install new plate and rivets as required.

5.42 DOORS/COVER REPAIR AND REPLACEMENT

This task covers:**a. Repair****b. Removal****c. Installation****INITIAL SETUP****Equipment Conditions:**

Refrigeration unit shut down (para 2.7) and power disconnected.

General Safety Instructions:**WARNING**

High voltage and rotating parts are used in the refrigeration unit. Personal injury can result if power is connected.

a. Repair.

- (1) If hinge is damaged, drill through rivets using drill bit slightly smaller than rivet diameter. Remove door/cover and hinge.
- (2) Remove any remaining rivet material.
- (3) Install new hinge, door/cover and rivets as necessary.
- (4) Repair any minor sheet metal dents and bent edges by straightening using common sheet metal repair procedures.
- (5) Weld any cracks or breaks in doors/cover per MIL-B-7883.
- (6) Touch-up any painted surfaces per TM 43-0139.

b. Removal.

- (1) Drill through rivets securing doors/cover to hinge using drill bit slightly smaller than rivet diameter.
- (2) Remove doors/cover and any remaining rivet material.

c. Installation. Install new door/cover and secure to hinge with rivets as necessary.

APPENDIX A

REFERENCES

A.1. SCOPE.

This appendix lists all forms, field manuals, and technical manuals referenced in this manual.

A.2 FORMS.

Recommended Changes to Publications..... DA Form 2028
 Recommended Changes to Equipment Technical Manuals..... DA Form 2028-2
 Product Quality Deficiency ReportStandard Form 368

A.3. FIELDS MANUALS.

NBC Contamination AvoidanceFM 3-3
 NBC ProtectionFM 3-4
 NBC DecontaminationFM 3-5

A.4. TECHNICAL MANUALS.

Destruction of Army Material to Prevent Enemy Use TM 750-244-3
 Unit, and Direct Support Maintenance Repair Parts and Special Tools List TM 9-4110-258-23P

A.5. MISCELLANEOUS PUBLICATIONS.

Army Logistics Readiness and Sustainability AR 700-138
 Army Maintenance Management System (TAMMS) DA Pam 738-750
 Expendable Items
 (Except Medical Class V, Repair Parts and Heraldic Items) CTA 50-970
 Army Medical Department Expendable/Durable Items CTA 8-100
 Methods of Preservation.....MIL-P-116
 Crates, Wood, Open And CoveredMIL-C-52950

A.6. WARRANTY TECHNICAL BULLETIN.

Refrigeration Unit, Mechanical, Electric 9K BTU Model F9000RE.....TB 9-4110-258-23

APPENDIX B**MAINTENANCE ALLOCATION CHART (MAC)**

Section I. INTRODUCTION**B-1. The Army Maintenance System MAC**

This introduction provides a general explanation of all maintenance and repair functions authorized at the two maintenance levels under the Two-Level Maintenance System concept.

This MAC (immediately following the introduction) designates overall authority and responsibility for the performance of maintenance functions on the identified end item or component. The application of the maintenance functions to the end item or component shall be consistent with the capacities and capabilities of the designated maintenance levels, which are shown on the MAC in column (4) as:

Field - includes two columns, Unit maintenance and Direct Support maintenance. The Unit maintenance column is divided again into two more subcolumns, C for Operator or Crew and O for Unit maintenance.

Sustainment – includes two subcolumns, General Support (H) and Depot (D).

The tools and test equipment requirements (immediately following the MAC) list the tools and test equipment (both special tools and common tool sets) required for each maintenance function as referenced from the MAC.

The remarks (immediately following the tools and test equipment requirements) contain supplemental instructions and explanatory notes for a particular maintenance function.

B-2. Maintenance Functions

Maintenance functions are limited to and defined as follows:

1. Inspect. To determine the serviceability of an item by comparing its physical, mechanical, and/or electrical characteristics with established standards through examination (e.g., by sight, sound, or feel.) This includes scheduled inspection and gaging and evaluation of cannon tubes.
2. Test. To verify serviceability by measuring the mechanical, pneumatic, hydraulic, or electrical characteristics of an item and comparing those characteristics with prescribed standards on a scheduled basis, i.e., load testing of lift devices and hydrostatic testing of pressure hoses.
3. Service. Operations required periodically to keep an item in proper operating condition; e.g., to clean (includes decontaminate, when required), to preserve, to drain, to paint, or to replenish fuel, lubricants, chemical fluids, or gases. This includes scheduled exercising and purging of recoil mechanisms. The following are examples of service functions:
 - a. Unpack. To remove from packing box for service or when required for the performance of maintenance operations.
 - b. Repack. To return item to packing box after service and other maintenance operations.
 - c. Clean. To rid the item of contamination.

- d. Touch up. To spot paint scratched or blistered surfaces.
 - e. Mark. To restore obliterated identification.
4. Adjust. To maintain or regulate, within prescribed limits, by bringing into proper position, or by setting the operating characteristics to specified parameters.
 5. Align. To adjust specified variable elements of an item to bring about optimum or desired performance
 6. Calibrate. To determine and cause corrections to be made or to be adjusted on instruments of test, measuring, and diagnostic equipment used in precision measurement. Consists of comparisons of two instruments, one of which is a certified standard of known accuracy, to detect and adjust any discrepancy in the accuracy of the instrument being compared.
 7. Remove/Install. To remove and install the same item when required to perform service or other maintenance functions. Install may be the act of emplacing, seating, or fixing into position a spare, repair part, or module (component or assembly) in a manner to allow the proper functioning of an equipment or system.
 8. Paint. To prepare and spray color coats of paint so that the ammunition can be identified and protected. The color indicating primary use is applied, preferably, to the entire exterior surface as the background color of the item. Other markings are to be repainted as original so as to retain proper ammunition identification.
 9. Replace. To remove an unserviceable item and install a serviceable counterpart in its place. "Replace" is authorized by the MAC and assigned maintenance level is shown as the third position code of the Source, Maintenance and Recoverability (SMR) code.
 10. Repair. The application of maintenance services, including fault location/troubleshooting, removal/installation, disassembly/assembly procedures and maintenance actions to identify troubles and restore serviceability to an item by correcting specific damage, fault, malfunction, or failure in a part, subassembly, module (component or assembly), end item, or system.

NOTE

The following definitions are applicable to the "repair" maintenance function:

Services. Inspect, test, service, adjust, align, calibrate, and/or replace.

Fault location/troubleshooting. The process of investigating and detecting the cause of equipment malfunctioning; the act of isolating a fault within a system or Unit Under Test (UUT).

Disassembly/assembly. The step-by-step breakdown (taking apart) of a spare/functional group coded item to the level of its least component, that is assigned an SMR code for the level of maintenance under consideration (i.e., identified as maintenance significant).

Actions. Welding, grinding, riveting, straightening, facing, machining, and/or resurfacing.

11. Overhaul. That maintenance effort (service/action) prescribed to restore an item to a completely serviceable/operational condition as required by maintenance standards in appropriate technical publications. Overhaul is normally the highest degree of maintenance performed by the Army. Overhaul does not normally return an item to like new condition.
12. Rebuild. Consists of those services/actions necessary for the restoration of unserviceable equipment to a like new condition in accordance with original manufacturing standards. Rebuild is the highest degree of material maintenance applied to Army equipment. The rebuild operation includes the act of returning to zero those age measurements (e.g., hours/miles.) considered in classifying Army equipment/components.

B-3. Explanation of Columns in the MAC, Section II

Column (1) Group Number. Column (1) lists Functional Group Code (FGC) numbers, the purpose of which is to identify maintenance significant components, assemblies, subassemblies, and modules with the Next Higher Assembly (NHA).

Column (2) Component/Assembly. Column (2) contains the names of components, assemblies, subassemblies, and modules for which maintenance is authorized.

Column (3) Maintenance Function. Column (3) lists the functions to be performed on the item listed in column (2). (For a detailed explanation of these functions refer to "Maintenance Functions" outlined above).

Column (4) Maintenance Level. Column (4) specifies each level of maintenance authorized to perform each function listed in column (3), by indicating work time required (expressed as man-hours in whole hours or decimals) in the appropriate subcolumn. This work time figure represents the active time required to perform that maintenance function at the indicated level of maintenance. If the number or complexity of the tasks within the listed maintenance function varies at different maintenance levels, appropriate work time figures are to be shown for each level. The work time figure represents the average time required to restore an item (assembly, subassembly, component, module, end item, or system) to a serviceable condition under typical field operating conditions. This time includes preparation time (including any necessary disassembly/assembly time), troubleshooting/fault location time, and quality assurance time in addition to the time required to perform the specific tasks identified for the maintenance functions authorized in the MAC. The system designations for the various maintenance levels are as follows:

Field:

- C Operator or Crew maintenance
- O Unit maintenance
- F Direct Support maintenance

Sustainment:

- L Specialized Repair Activity
- H General Support maintenance
- D Depot maintenance

NOTE

The "L" maintenance level is not included in column (4) of the MAC. Functions to this level of maintenance are identified by work time figure in the "H" column of column (4), and an associated reference code is used in the REMARKS column (6). This code is keyed to the remarks and the SRA complete repair application is explained there.

Column (5) Tools and Equipment Reference Code. Column (5) specifies, by code, those common tool sets (not individual tools), common Test, Measurement and Diagnostic Equipment (TMDE), and special tools, special TMDE and special support equipment required to perform the designated function. Codes are keyed to the entries in the tools and test equipment table.

Column (6) Remarks Code. When applicable, this column contains a letter code, in alphabetic order, which is keyed to the remarks table entries.

B-4. Explanation of Columns in the Tools and Test Equipment Requirements, Section III

Column (1) - Tool or Test Equipment Reference Code. The tool or test equipment reference code correlates with a code used in column (5) of the MAC.

Column (2) - Maintenance Level. The lowest level of maintenance authorized to use the tool or test equipment.

Column (3) - Nomenclature. Name or identification of tool or test equipment.

Column (4) - National Stock Number (NSN). The NSN of the tool or test equipment.

Column (5) - Tool Number. The manufacturer's part number.

B-5. Explanation of Columns in Remarks, Section IV

Column (1) - Remarks Code. The code recorded in column (6) of the MAC.

Column (2) - Remarks. This column lists information pertinent to the maintenance function being performed as indicated in the MAC.

**Section II. MAINTENANCE ALLOCATION CHART
FOR
REFRIGERATION UNIT, MECHANICAL, 9K BTU, ELECTRIC MODEL F9000RE**

(1) GROUP NUMBER	(2) COMPONENT/ ASSEMBLY	(3) MAINTENANCE FUNCTION	(4) MAINTENANCE LEVEL					(5) TOOLS AND EQUIPMENT REFERENCE CODE	(6) REMARKS CODE
			FIELD		SUSTAINMENT				
			UNIT		DIRECT SUPPORT	GENERAL SUPPORT	DEPOT		
			C	O	F	H	D		
00	REFRIGERATION UNIT								
01	PANELS & GUARDS								
	PANELS	Inspect Repair Replace	0.1		1.0			1 1	
	GUARD	Inspect Repair Replace	0.1		1.0			1 1	
02	ELECTRICAL AND CONTROL SYSTEM								
	WIRES, CABLES, & HARNESSES	Inspect Test Repair Replace		0.5 0.5 1.0 2.0				1, 3 1, 3 1, 3	
	INDICATORS/ LAMPS	Inspect Test Replace	0.1	0.5 1.0				1 1	
	SWITCH, TOGGLE	Inspect Test Replace	0.1	0.5 1.0				1 1	
	HOURMETER	Inspect Test Replace	0.1	0.5 1.0				1 1	
	CIRCUIT BREAKER	Inspect Test Replace	0.1	0.5 1.0				1 1	
	THERMOSTAT	Inspect Test Replace	0.1	0.5 1.0				1 1	
	FUSES	Inspect Test Replace		0.1 0.5 0.2				1 1	
	STARTER, MOTOR	Inspect Test Repair Replace		0.1 0.5 0.5 1.0				1 1 1 1	
	CONTACTORS	Inspect Test Replace		0.1 0.5 1.0				1 1	
	RELAYS, CONTROL	Inspect Test Replace		0.1 0.5 1.0				1 1, 3	
	TIMER, DEFROST	Inspect Test Replace		0.1 0.5 1.0				1 1	

**Section II. MAINTENANCE ALLOCATION CHART
FOR
REFRIGERATION UNIT, MECHANICAL, 9K BTU, ELECTRIC MODEL F9000RE - continued**

(1) GROUP NUMBER	(2) COMPONENT/ ASSEMBLY	(3) MAINTENANCE FUNCTION	(4) MAINTENANCE LEVEL					(5) TOOLS AND EQUIPMENT REFERENCE CODE	(6) REMARKS CODE
			FIELD		SUSTAINMENT				
			UNIT		DIRECT SUPPORT	GENERAL SUPPORT	DEPOT		
			C	O	F	H	D		
03	SWITCHES, PUSH	Inspect Test Replace	0.1	0.5 1.0				1 1, 3	
	POWER TRANSMISSION/ AIR HANDLING								
	V-BELT	Inspect Adjust Replace	0.1	0.5 0.5				1 1	
	PULLEYS	Inspect Replace	0.1	0.1				1	
	MOTOR, AC	Inspect Test Replace		0.1 1.0 1.0				1 1	
	BEARINGS, FLANGE	Inspect Service Replace	0.1	0.2 2.0				1 1	
	FANS	Inspect Replace	0.1	0.5 0.1				1 1	C, D
04	SHAFT, FAN DRIVE	Inspect Replace	0.1		4.0			1, 4, 5, 6	
	REFRIGERATION SYSTEM								
	DEHYDRATOR	Inspect Replace	0.1		3.0			1, 4, 5, 6	
	STRAINER	Inspect Replace	0.1		3.0			1, 4, 5, 6	
	RECEIVER	Inspect Replace	0.1		3.0			1, 4, 5, 6	
	VALVES, PRESSURE REGULATOR	Inspect Replace	0.1		3.0			1, 4, 5, 6	
	VALVE, CHECK	Inspect Replace	0.1		3.0			1, 4, 5, 6	
	HOSE ASSEMBLIES, METAL	Inspect Replace	0.1		3.0			1, 4, 5, 6	
	ACCUMULATOR	Inspect Replace	0.1		3.0			1, 4, 5, 6	
	VALVES/COILS, SOLENOID	Inspect Test Repair Replace	0.1	0.3 1.0	3.0 3.0			1, 4, 5, 6 1, 4, 5, 6	A, B

**Section II. MAINTENANCE ALLOCATION CHART
FOR
REFRIGERATION UNIT, MECHANICAL, 9K BTU, ELECTRIC MODEL F9000RE - continued**

(1) GROUP NUMBER	(2) COMPONENT/ ASSEMBLY	(3) MAINTENANCE FUNCTION	(4) MAINTENANCE LEVEL					(5) TOOLS AND EQUIPMENT REFERENCE CODE	(6) REMARKS CODE
			FIELD		SUSTAINMENT				
			UNIT	DIRECT SUPPORT	GENERAL SUPPORT	DEPOT			
			C	O	F	H	D		
05	VALVES, STOP	Inspect Replace	0.1		3.0			1, 4, 5, 6	
	INDICATOR, SIGHT	Inspect Replace	0.1		3.0			1, 4, 5, 6	
	COIL, CONDENSER	Inspect Service Replace		0.1 1.0	4.0			2 1, 4, 5, 6	
	TUBING AND FITTINGS	Inspect Test Repair Replace	1.0		1.0 1.0 3.0			1 1, 4, 5, 6	
	SWITCHES, PRESSURE	Inspect Replace	0.1		3.0			1, 4, 5, 6	
	THERMOMETER	Inspect Replace	0.1	2.0				1, 4, 5, 6	
	GAGES, PRESSURE	Inspect Replace	0.1		3.0			1, 4, 5, 6	
	HEATER, ELECTRIC	Inspect Test Replace	0.1		0.5 1.0			1 1	
	SWITCH, THERMOSTATIC	Inspect Test Replace		0.1 0.5 1.0				1 1	
	SWITCH, TEMPERATURE	Inspect Test Replace		0.1 0.5 1.0				1 1	
	HEAT EXCHANGER	Inspect Replace		0.1	3.0			1, 4, 5, 6	
	VALVE, EXPANSION	Inspect Replace		0.1	3.0			1, 4, 5, 6	
	COIL, EVAPORATOR	Inspect Service Replace		0.1 1.0	4.0			1 1, 4, 5, 6	
	COMPRESSOR	Inspect Service Test Repair Replace	0.1		0.5 0.5 8.0 6.0			1, 4 1, 4 1, 4 1, 4, 5, 6	
	ENCLOSURE GASKET	Inspect Replace	0.1	1.0				1	
	ENCLOSURE, CONDENSER	Inspect Repair	0.1		2.0			1	
	PLATES	Inspect Replace	0.1		2.0			1, 4	

**Section II. MAINTENANCE ALLOCATION CHART
FOR
REFRIGERATION UNIT, MECHANICAL, 9K BTU, ELECTRIC MODEL F9000RE - continued**

(1) GROUP NUMBER	(2) COMPONENT/ ASSEMBLY	(3) MAINTENANCE FUNCTION	(4) MAINTENANCE LEVEL					(5) TOOLS AND EQUIPMENT REFERENCE CODE	(6) REMARKS CODE	
			FIELD		SUSTAINMENT					
			UNIT		DIRECT SUPPORT	GENERAL SUPPORT	DEPOT			
			C	O	F	H	D			
	DOORS/COVER	Inspect Service Repair Replace	0.1	0.5	1.0 1.0			1, 4 1, 4 1, 4		
	BOLTS, BARREL	Inspect Service Replace	0.1	0.1 0.5				1, 4 1		

**Section III. TOOLS AND TEST EQUIPMENT
FOR
REFRIGERATION UNIT, MECHANICAL, 9K BTU, ELECTRIC MODEL F9000RE**

(1) TOOL OR TEST EQUIPMENT REFERENCE CODE	(2) MAINTENANCE LEVEL	(3) NOMENCLATURE	(4) NATIONAL STOCK NUMBER	(5) TOOL NUMBER
NOTE				
Standard tools and test equipment in the following kits are adequate to accomplish the maintenance functions listed in Section II.				
1	O	Shop Equipment (1), Automotive Vehicle	4910-00-754-0654	SC 4910-95-CL-A74
2	O	Comb, Fin	5120-00-916-6197	
3	O	Heat Gun	3439-01-037-7268	
4	F	Tool Kit, Service, Refrigeration Unit	5180-00-597-1474	SC 5180-90-CL-N18
5	F	Recovery and Recycle Unit, Refrigerant	4130-01-359-4516	
6	F	Nitrogen Regulator	6680-00-503-1327	

**Section IV. REMARKS
FOR
REFRIGERATION UNIT, MECHANICAL, 9K BTU, ELECTRIC MODEL F9000RE**

(1) REMARKS CODE	(2) REMARKS
A	Repair at unit maintenance level is limited to replacement of electric coil.
B	Repair at direct support maintenance level is limited to replacement of valve body.
C	Inspection at operator maintenance level is limited to condenser fan only.
D	Inspection at unit maintenance level is limited to evaporator fan only.
	NOTE
	Other than those items listed above there are no supplemental instructions or explanatory remarks required for the maintenance functions listed in Section II. All functions are sufficiently defined in Section I. Active time listed for maintenance task functions are with the refrigeration unit in off-equipment position.

APPENDIX C**COMPONENTS OF END ITEM (COEI) AND BASIC ISSUE ITEMS LIST****SECTION I INTRODUCTION****C.1. SCOPE.**

This appendix list components of the end item and basic issue items for the refrigeration unit to help you inventory the items for safe and efficient operation of the equipment.

C.2. GENERAL.

The Components of End Item (COEI) and Basic issue Items (BII) Lists are divided into the following sections:

C.2.1. Section II. Components of End Item. This listing is for information purposes only, and is not authority to requisition replacements. These items are part of the refrigeration unit. As part of the end item, these items must be with the end item whenever it is issued or transferred between property accounts. Items of COEI are removed and separately packaged for transportation or furnished to help you find and identify the items.

C.2.2. Section III. Basic Issue Items. These essential items are required to place the refrigeration unit in operation, operate it, and to do emergency repairs. Although shipped separately packaged, BII must be with the refrigeration unit during operation and when it is transferred between property accounts. This list is your authority to request/requisition them for replacement based on authorization of the end item by the TOE/MTOE. Illustrations are furnished to help you find and identify the items.

C.2.3. Explanation of Columns.

C.2.3.1. Column (1), Illus Number, gives you the number of the item illustrated.

C.2.3.2. Column (2), National Stock Number, identifies the stock number of the item to be used for requisitioning purposes.

C.2.3.3. Column (3), Description and Usable On Code, identifies the Federal item name (in all capital letters) followed by a minimum description when needed. The last line below the description is the Commercial and Government Entity Code (CAGEC) (in parentheses) and the part number.

C.2.3.4. Column (4), U/I (unit of issue), indicates how the item is issued for the National Stock Number shown in column two.

C.2.3.5. Column (5), Qty Rqd, indicates the quantity required.

SECTION II COMPONENTS OF END ITEM

There are no loose or separate components supplied with this refrigeration unit.

SECTION III BASIC ISSUE ITEMS LIST

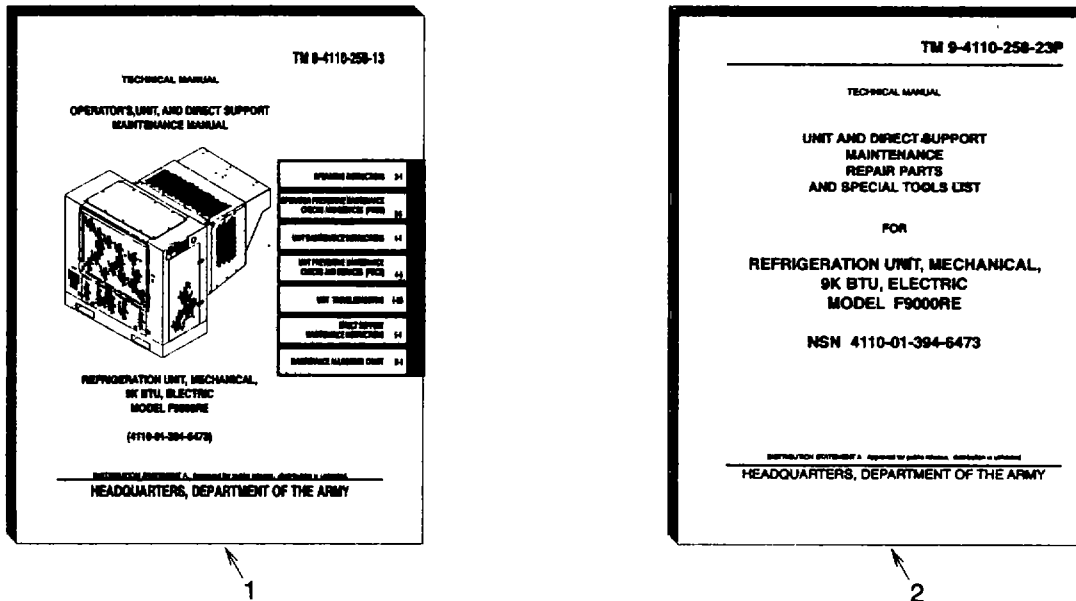

Figure C-1. Basic Issue Items

(1) ILLUS NUMBER	(2) NATIONAL STOCK NUMBER	(3) DESCRIPTION CAGE and Part Number	(4) U/M	(5) QTY RQD
1		ARMY TECHNICAL MANUAL Operator's, Unit and Direct Support Maintenance for Refrigeration Unit, Mechanical 9K BTU Electric, Model F9000RE TM 9-4110-258-13	EA	1
2		ARMY TECHNICAL MANUAL Unit and Direct Support Maintenance Repair Parts and Special Tools List for Refrigeration Unit, Mechanical, 9K BTU, Electric Model F900RE TM 9-4110-258-23P	EA	1

APPENDIX D

ADDITIONAL AUTHORIZATION LIST

There are no additional authorized items required for this refrigeration unit.

APPENDIX E**EXPENDABLE AND DURABLE ITEMS LIST****SECTION I INTRODUCTION****E.1. SCOPE.**

This appendix lists expendable and durable items you will need to maintain the refrigeration unit. This listing is for informational purposes only and is not authority to requisition the listed items. These items are authorized by CTA 50-970, expendable items (except Medical, Class V, Repair Parts, and Heraldic Items).

E.2. EXPLANATION OF COLUMNS.

E.2.1. Column (1) - Item Number. This number is assigned to the entry in the listing for referencing when required.

E.2.2. Column (2) - Level. This column identifies the lowest level of maintenance that requires the listed item.

C - Operator/Crew

O - Unit Maintenance

F - Direct Support Maintenance

E.2.3. Column (3) - National Stock Number. This is the national stock number assigned to the item; use it to request or requisition the item.

E.2.4. Column (4) - Description. Indicates the federal item name and, if required a description to identify the item. The last line for each item indicates the Commercial and Government Entity Code (CAGEC) in parentheses followed by the part number.

E.2.5. Column (5) - Unit of Measure (U/M) Unit of Issue (U/I). This measure is expressed by a two character alphabetical abbreviation (e.g., EA, IN, PR). If the unit of measure differs from the unit of issue as shown in the Army Master Data File (AMDF) requisition the lowest unit of issue that will satisfy your requirements.

SECTION II EXPENDABLE AND DURABLE ITEMS LIST

(1) Item Number	(2) Level	(3) National Stock Number	(4) Description	(5) (U/M)/ (U/I)
1	O	7510-00-266-5006	Tape, Waterproof Packaging, PPP-T-60, Type IV	roll
2	O	8135-00-664-6958	Greaseproofed, Waterproof, Flexible Barrier Material, PP-C-843, Type II Class B	roll
3	O	7920-00-205-1711	Wiping Rag	bl
4	O	7930-00-985-6911	Detergent (81349) MIL-D-16791	gl
5	O	9150-01-178-4725	Lubricating Oil, General Purpose MIL-L-2104	qt
6	O	9150-00-985-7316	Grease, Multipurpose MIL-G-23549	lb
7	O	9905-00-537-8954	Marker Tag, MIL-T-12755	box
8	O	5935-00-725-4153	Solder, Lead-Tin, QQ-S-571 Type SN60WRP2	roll
9	F	3439-00-640-3713	Flux, Brazing O-F-499, type B	oz
10	O	5640-00-580-6276	Insulation Tape	roll
11	F	6830-00-292-0732	Nitrogen	cy
12	F		Refrigerant, R134a	lb
13	O	5350-00-192-5047	Abrasive Cloth	pg
14	O	3040-00-644-0439	Adhesive, General Purpose,	pt
15	F		Brazing Alloy, Silver QQ-B-564, grade 0, I or II	oz
16	F		Brazing Alloy, Silver QQ-B-564, grade III	oz
17	O	3439-01-045-7940	Flux, Solder, Liquid, Rosin Base MIL-F-14256	qt
18	F		Acetone	gl
19	F		Methyl-ethyl Ketone	gl
20	O		Adhesive-Sealant, Silicone RTV MIL-A-46106, Type I	oz

(1) Item Number	(2) Level	(3) National Stock Number	(4) Description	(5) (U/M)/ (U/I)
21	F		Lubricating Oil, Compressor, Refrigeration (14569) Arctic 22 CC	gl
22	F		Tape, Anti-Seize MIL-T-27730, Size I	roll
23	O		Tie Down Strap (Long) (96906)	hd
24	O		Tie Down Strap (Short) (96906)	hd

APPENDIX F

ILLUSTRATED LIST OF MANUFACTURED ITEMS

SECTION I

F.1. SCOPE.

This appendix includes complete instructions for making items authorized to be manufactured or fabricated at unit, and direct support maintenance.

F.1.1. A part number index in alphanumeric order is provided for cross-referencing the part number of the item to be manufactured to the figure which covers fabrication criteria.

F.1.2. All bulk materials needed for manufacture of an item are listed by part number or specification number in a tabular list on the illustration.

F.1.3. All dimensions are given in inches with centimeters shown in parenthesis.

F.1.4. For fabrication information of electrical wires including lengths and markings, see Table 4-3.

SECTION II

F.2. MANUFACTURED ITEMS PART NUMBER LIST.

<u>Part Number</u>	<u>Figure Number</u>
12075-5-1610	F-1
12075-9-1875	F-1
12075-10-2000	F-1
12075-10-9000	F-1
12076-3-1000	F-2
12076-5-1250	F-2
12076-5-1813	F-2
12076-6-1000	F-2
149K0051-3.....	F-1
150K0201-1/3.....	F-31
151K0052-1.....	F-3
152K0oO-1/57	F-28
152K0000-1/155	F-29
152K0000-1/172	F-30
152KO000-1/i191	F-3
152K0000-1 /192	F-31
152K0009-1/54.....	F-31
152K0036.....	F-4
152K0037.....	F-5
152K0042-1/4.....	F-31
152K0116.....	F-6
152K0117	F-7
152K0158-1 & -2	F-8
152K0159.....	F-9
152K0160.....	F-10
152K0161.....	F-11
152K0171	F-12

<u>Part Number</u>	<u>Figure Number</u>
152K0172.....	F-13
152K0173.....	F-14
152K0174.....	F-15
152K0175.....	F-16
152K0176.....	F-17
152K0177.....	F-18
152K0178.....	F-19
152K0179.....	F-20
152K0180.....	F-32
152K0182-1.....	F-33
152K0190.....	F-1
152K0191.....	F-1
152K0192.....	F-34
152K0193.....	F-21
152K0194.....	F-22
152K0195.....	F-23
152K0196.....	F-24
152K0197.....	F-25
152K0198.....	F-26
152K0205-1.....	F-35
500K1662-2-11.33.....	F-27

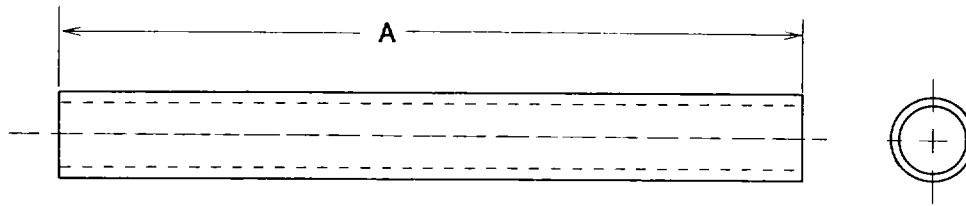

ITEM.	PART NO.	DIM "A"	FABRICATE FROM
1	12075-5-1610	1.610 (4.089)	0.375 (.953) O.D. X 0.032 (0.081) WALL ASTM B280 COPPER TUBING
2	12075-9-1875	1.875 (4.763)	0.875 (2.223) O.D. X 0.045 (0.114) WALL ASTM B280 COPPER TUBING
3	12075-10-2000	2.000 (5.080)	1.125 (2.858) O.D. X 0.050 (0.127) WALL ASTM 8280 COPPER TUBING
4	12075-10-9000	9.000 (22.860)	1.125 (2.858) O.D. X 0.050 (0.127) WALL ASTM B280 COPPER TUBING
5	149K0051-3/3	90.00 (228.60)	0.125 (.318) O.D. X 0.030 (0.076) WALL ASTM B280 COPPER TUBING
6	152K0190	3.25 (8.26)	1.125 (2.858) O.D. X 0.050 (0.127) WALL ASTM B280 COPPER TUBING
7	152K0191	2.50 (6.35)	1.125 (2.858) O.D. X 0.050 (0.127) WALL ASTM B280 COPPER TUBING

Figure F-1. Tube, Copper Straight, Various

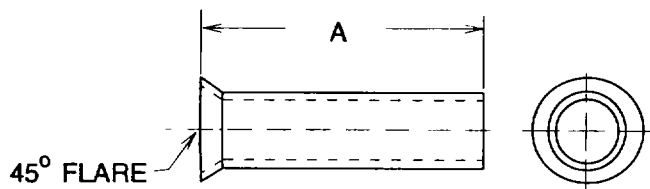

ITEM	PART NO.	DIM "A"	FABRICATE FROM
1	12076-3-1000	1.000 (2.540)	250 (0.635) O.D. X 0.030 (0.076) WALL ASTM B280 COPPER TUBING
2	12076-5-1250	1.250 (3.175)	0.375 (.953) O.D. X 0.032 (0.081) WALL ASTM B280 COPPER TUBING
3	12076-5-1813	1.813 (4.605)	0.375 (.953) O.D. X 0.032 (0.081) WALL ASTM B280 COPPER TUBING
4	12076-6-1000	1.000 (2.540)	0.500 (1.270) O.D. X 0.032 (0.081) WALL ASTM B280 COPPER TUBING

Figure F-2. Tubing Copper, Straight Flared, Various

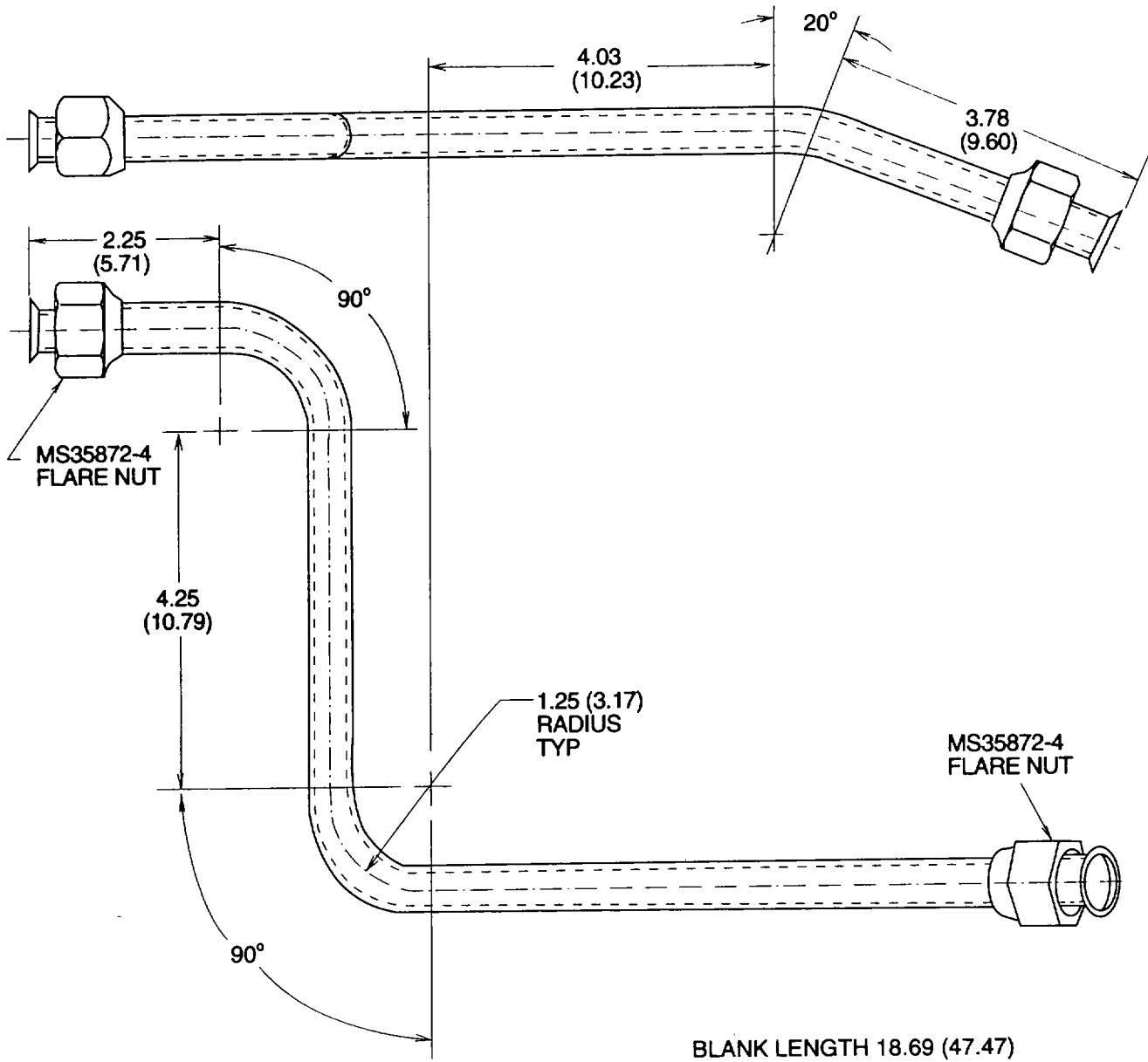

NOTE

1. FABRICATE FROM .500 (1.27) O.O. X 0.032 (0.081) WALL ASTM B280 COPPER TUBING

Figure F-3. Tube, Receiver to Filter Drier, Part Number 151K0052-1

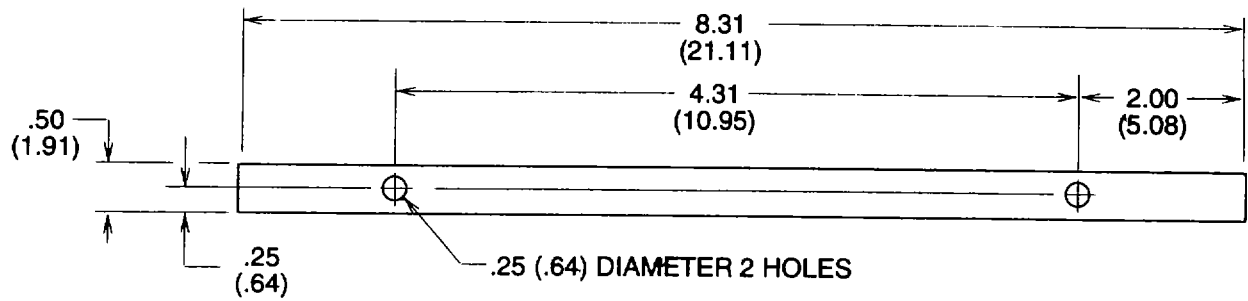

NOTE

1. FABRICATE FROM ASTM D1056-2A2C2F2 0.125 (0.318) THICK RUBBER GASKET

Figure F-4. Gasket, Control Box, Part Number 152K0036

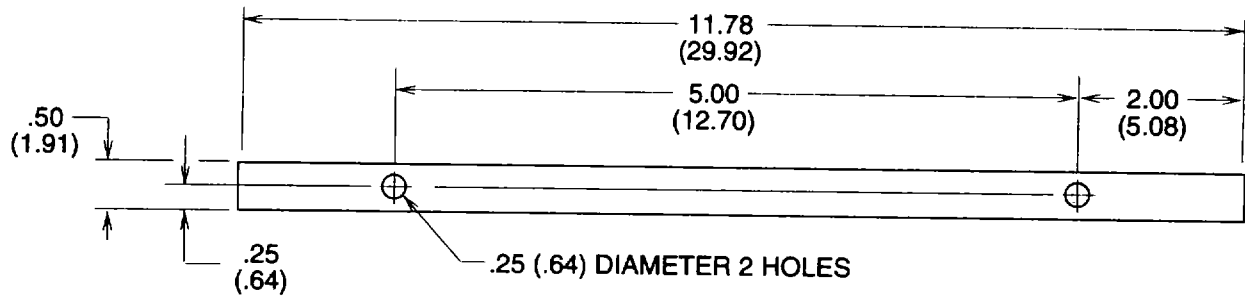

NOTE

1. FABRICATE FROM ASTM D1056-2A2C2F2 0.125 (0.318) THICK RUBBER GASKET

Figure F-5. Gasket, Control Box, Side, Part Number 152K0037

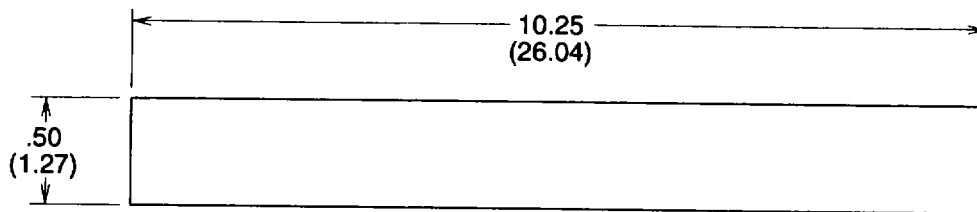

NOTE

1. FABRICATE FROM ASTM D1056-2A2C2F2 0.125 (0.318) THICK RUBBER GASKET

Figure F-6. Gasket, Part Number 152K0116

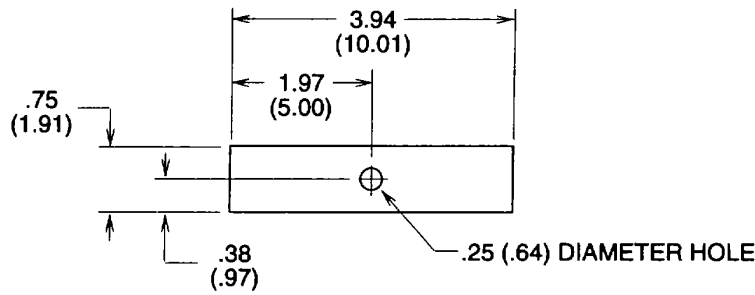

NOTE
 1. FABRICATE FROM ASTM D1056-2A2C2F2
 0.125 (0.318) THICK RUBBER GASKET

Figure F-7. Gasket, Circuit Breaker Panel, Part Number 152K0117

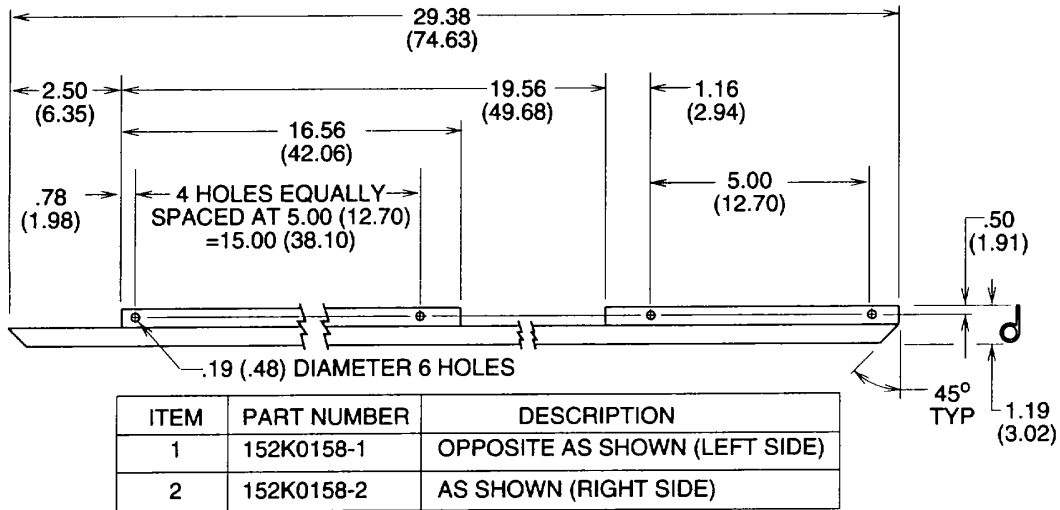

NOTE
 1. FABRICATE FROM (74951) V-1234-100

Figure F-8. Gasket, Inside, Right/Left Side, Part Number 152K0158-1 & -2

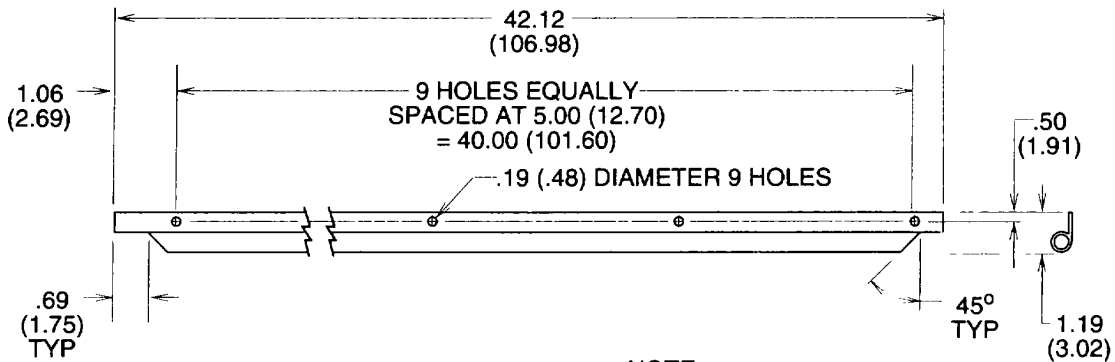

NOTE
 1. FABRICATE FROM (74951) V-1234-100

Figure F-9. Gasket, Outside, Top/Bottom, Part Number 152K0159

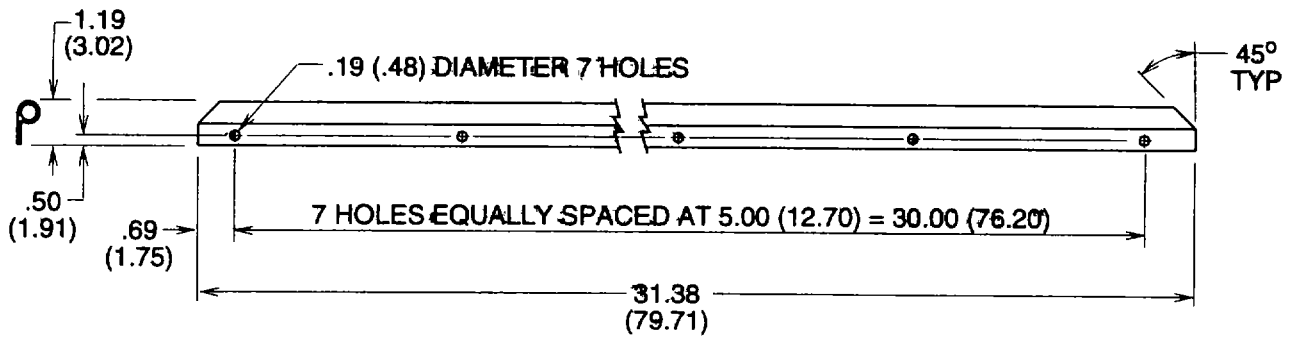

NOTE

1. FABRICATE FROM (74951) V-1234-100

Figure F-10. Gasket, Outside, Right/Left Side, Part Number 152K0160

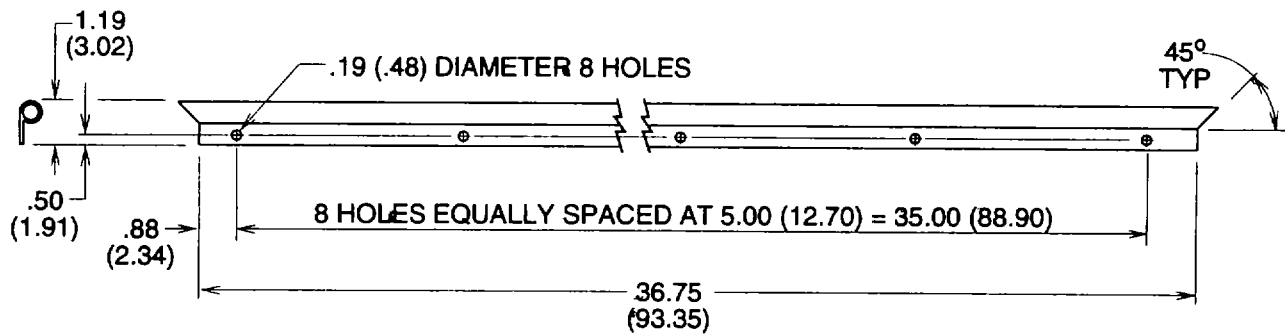

NOTE

1. FABRICATE FROM (74951) V-1234-100

Figure F-11. Gasket, Inside, Top/Bottom, Part Number 152K0161

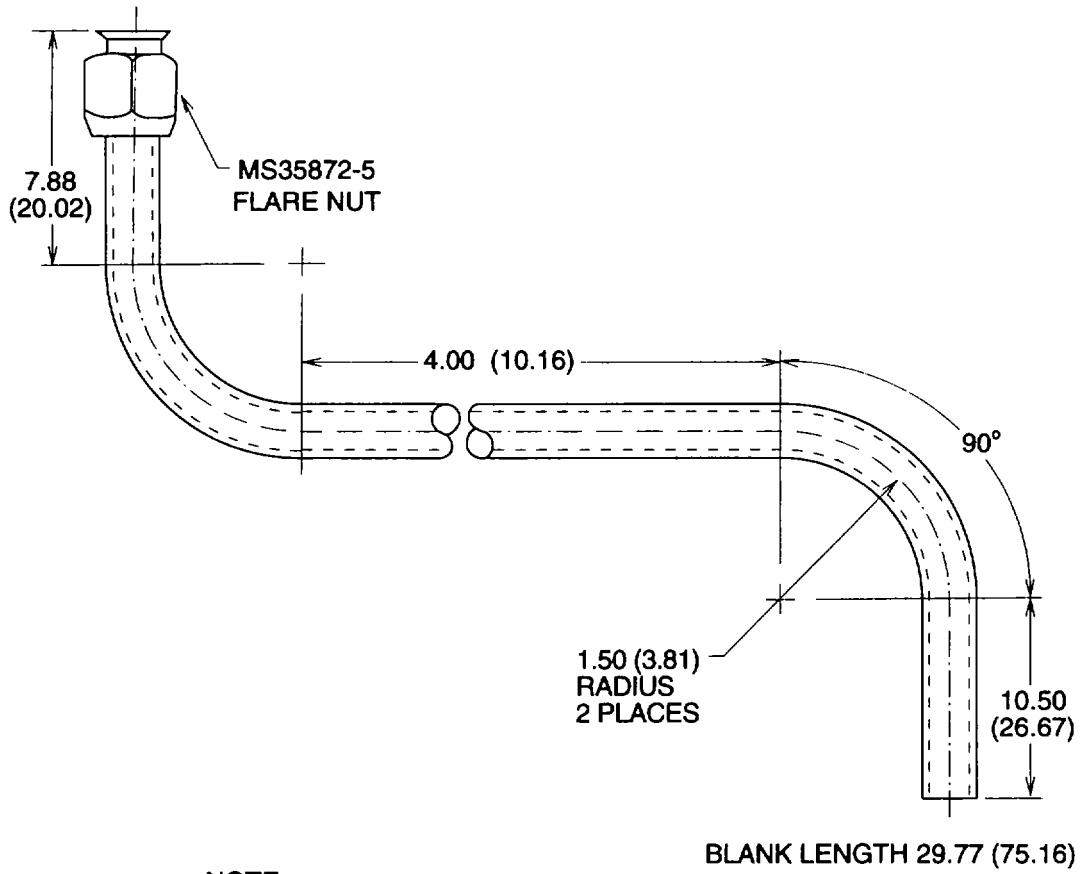

NOTE

1. FABRICATE FROM .63 (1.60) O.D. X 0.035 (0.088) WALL ASTM B280 COPPER TUBING

Figure F-12. Tube Assembly, Outlet, Condenser Coil, Part Number 152K0171

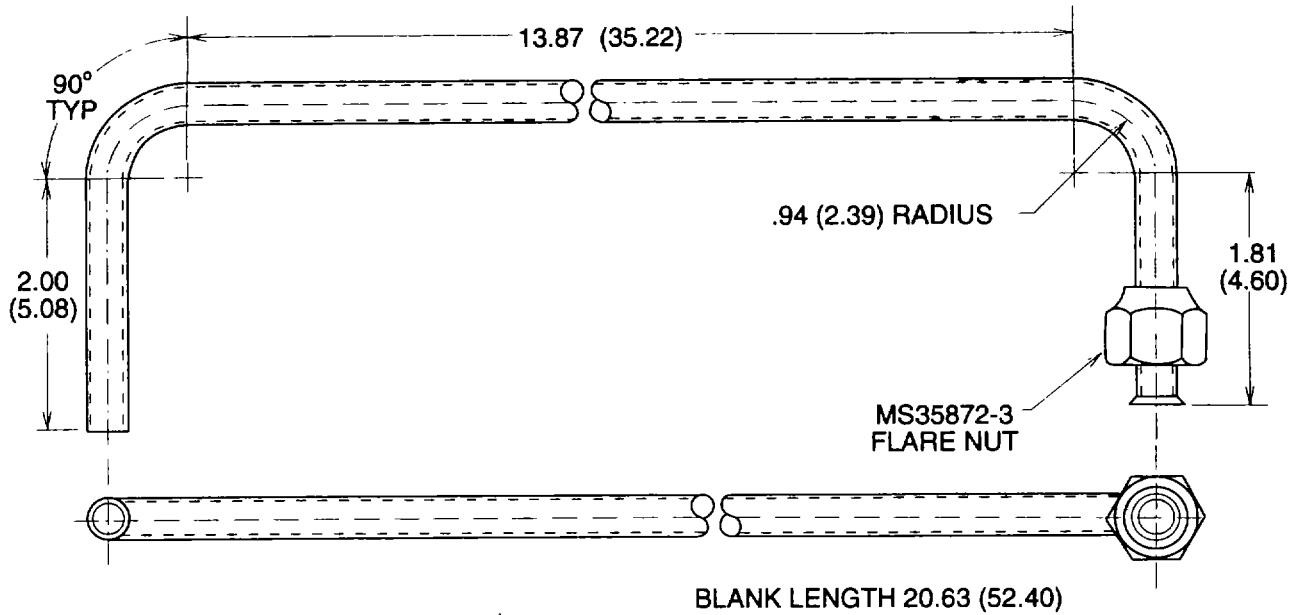

NOTE

1. FABRICATE FROM .375 (.952) O.D. X 0.032 (0.081) WALL ASTM B280 COPPER TUBING

Figure F-13. Tube Assembly, Outlet, Solenoid Valve (Liquid Line), Part Number 152K0172

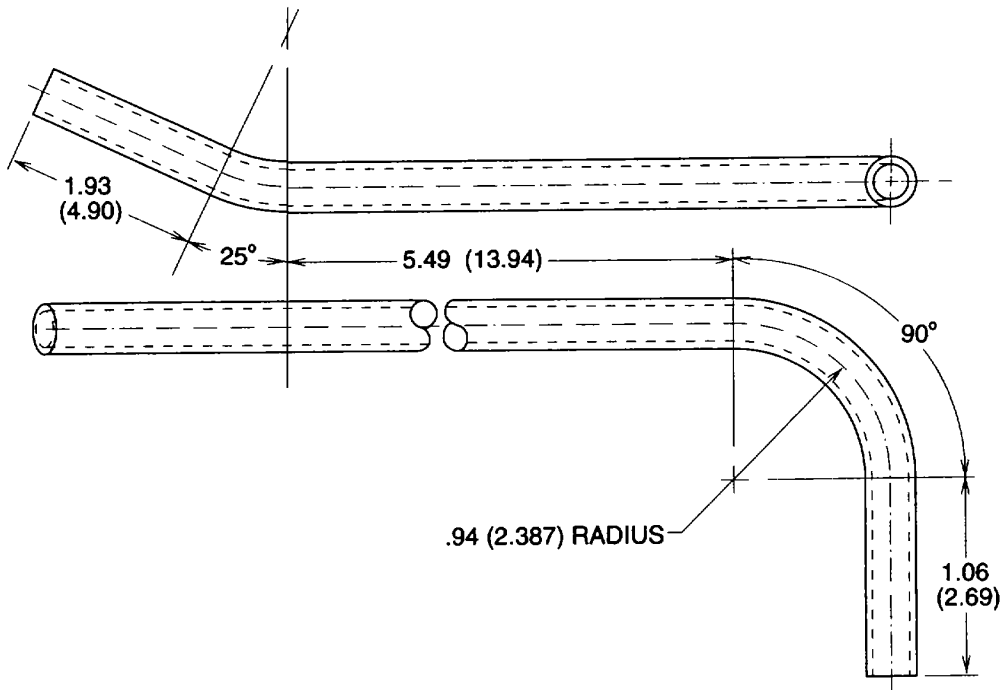

BLANK LENGTH 10.36 (26.31)

NOTE

1. FABRICATE FROM .375 (.953) O.D. X 0.032 (0.081) WALL ASTM B280 COPPER TUBING

Figure F-14. Tube, Outlet, Sight Glass, Part Number 152K0173

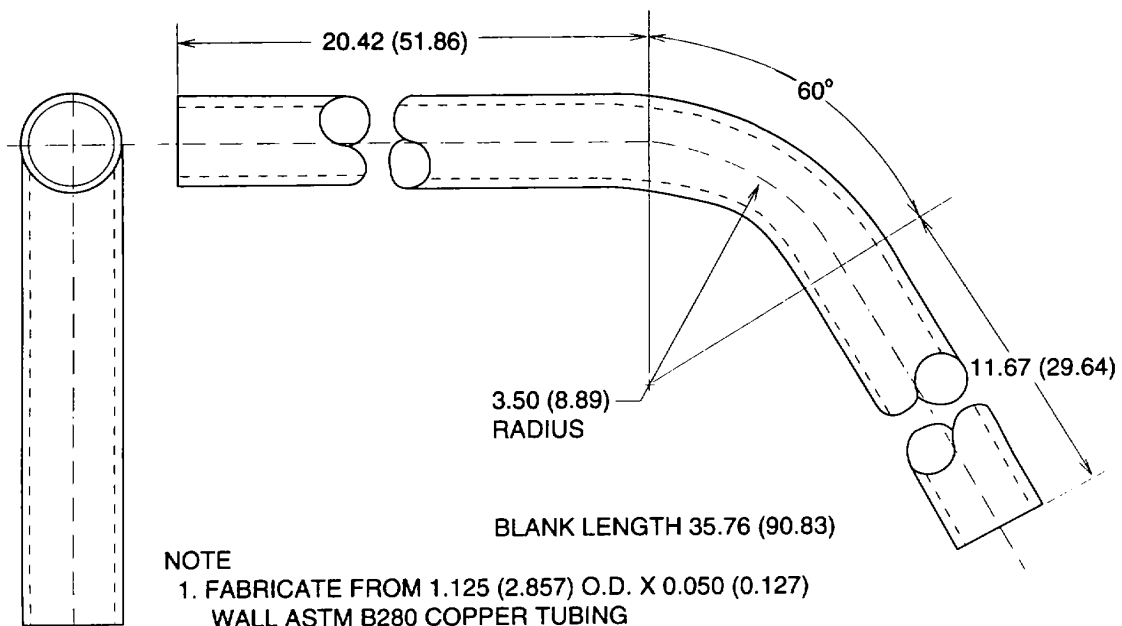

BLANK LENGTH 35.76 (90.83)

NOTE

1. FABRICATE FROM 1.125 (2.857) O.D. X 0.050 (0.127) WALL ASTM B280 COPPER TUBING

Figure F-15. Tube, Outlet, Heat Exchanger, Part Number 152K0174

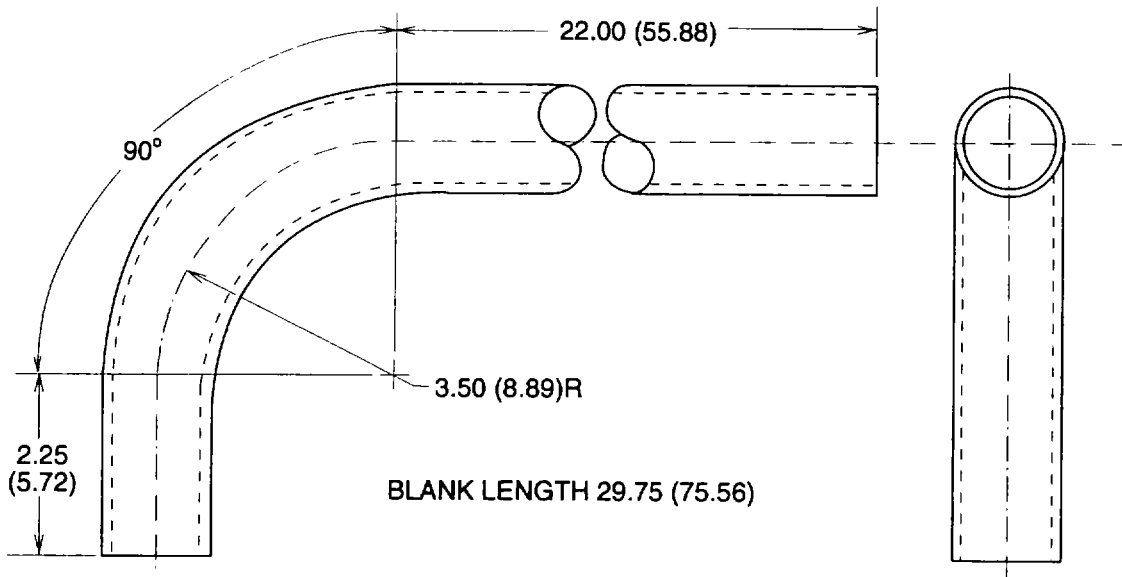

NOTE

1. FABRICATE FROM 1.125 (2.875) O.D. X 0.050 (0.127) WALL ASTM B280 COPPER TUBING

Figure F-16. Tube, Outlet, Accumulator, Part Number 152K0175

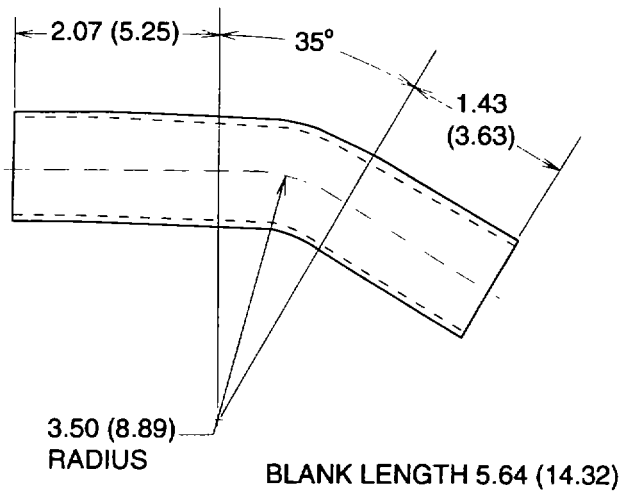

NOTE

1. FABRICATE FROM 1.125 (2.857) O.D. X 0.050 (0.127) WALL ASTM B280 COPPER TUBING

Figure F-17. Tube, Outlet, Vibration Isolator (Suction Line), Part Number 152K0176

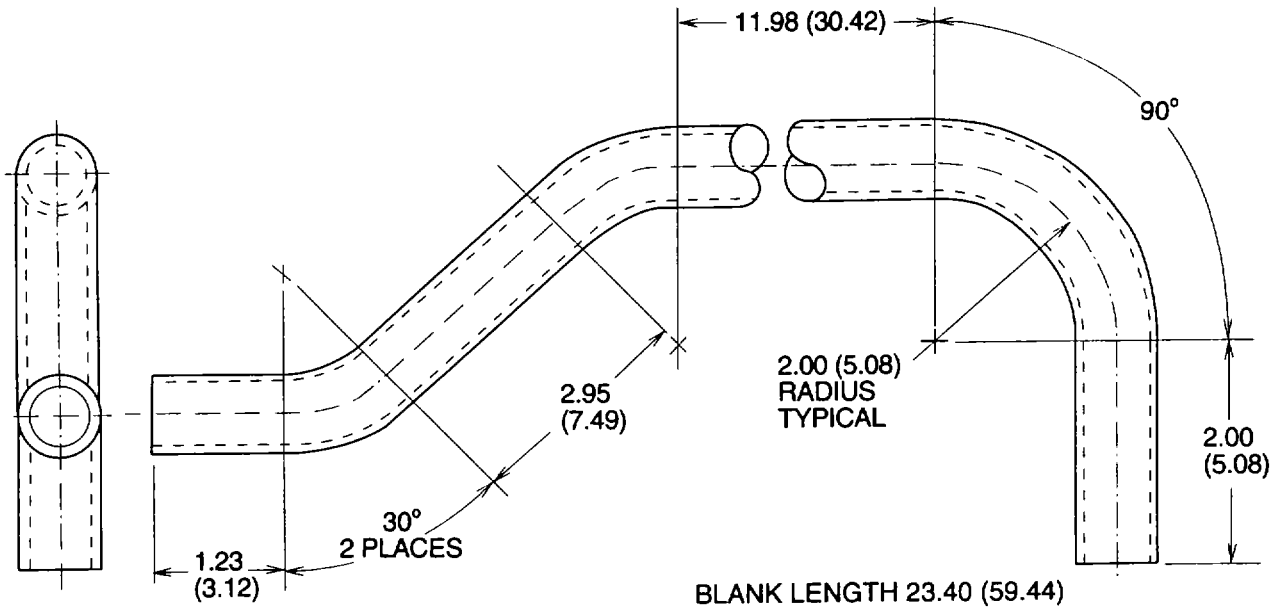

NOTE
1. FABRICATE FROM .875 (2.222) O.D. X 0.045 (0.114)
WALL ASTM B280 COPPER TUBING

Figure F-18. Tube, Outlet, Vibration Isolator (Discharge Line), Part Number 152K0177

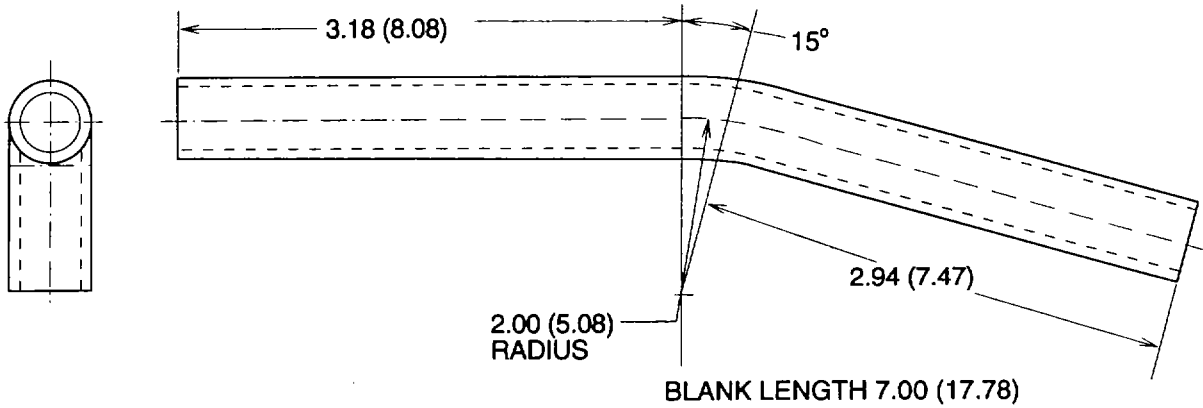

NOTE
1. FABRICATE FROM .875 (2.222) O.D. X 0.045 (0.114)
WALL ASTM B280 COPPER TUBING

Figure F-19. Tube, Outlet, Discharge Pressure Regulator Valve, Part Number 152K0178

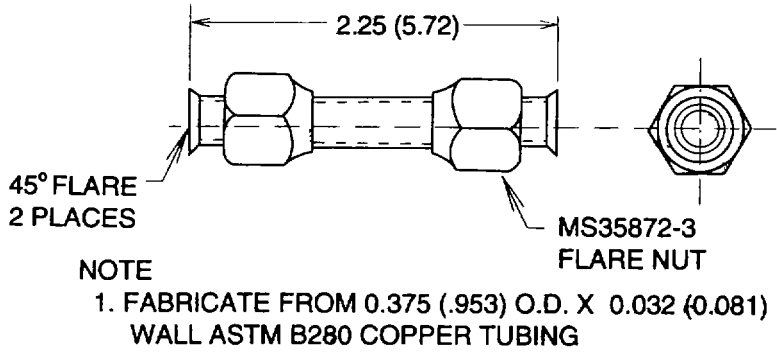
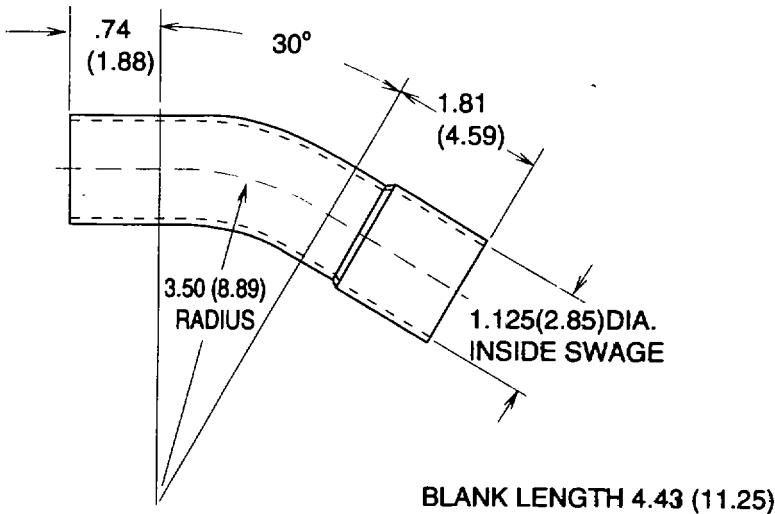
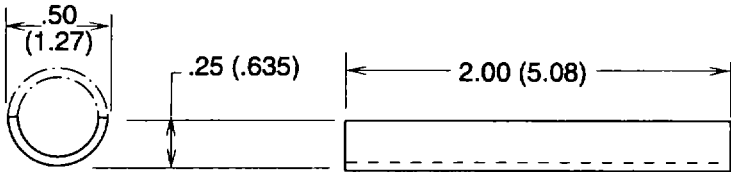

Figure F-20. Tube Assembly, Outlet, Strainer, Part Number 152K0179



NOTE
1. FABRICATE FROM 1.125 (2.857) O.D. X 0.050 (0.127)
WALL ASTM B280 COPPER TUBING

Figure F-21. Tube, Header to Elbow, Part Number 152K0193



NOTE
1. FABRICATE FROM 0.50 (1.27) X .032 (.0812)
WALL ASTM B280 COPPER TUBING

Figure F-22. Contact Cradle, Sensing Bulb, Part Number 152K0194

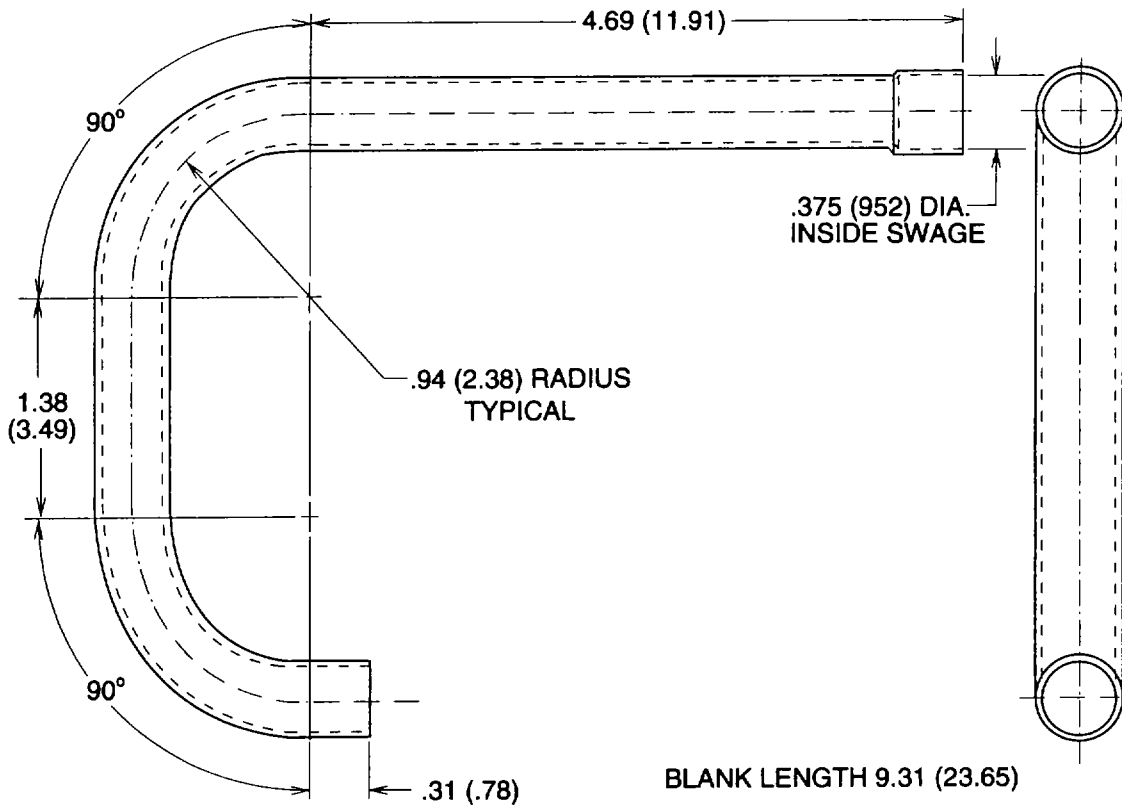

NOTE

1. FABRICATE FROM .375 (.952) O.D. X 0.032 (0.81) WALL ASTM B280 COPPER TUBING

Figure F-23. Tube, Heat Exchanger to Tube, Part Number 152K0195

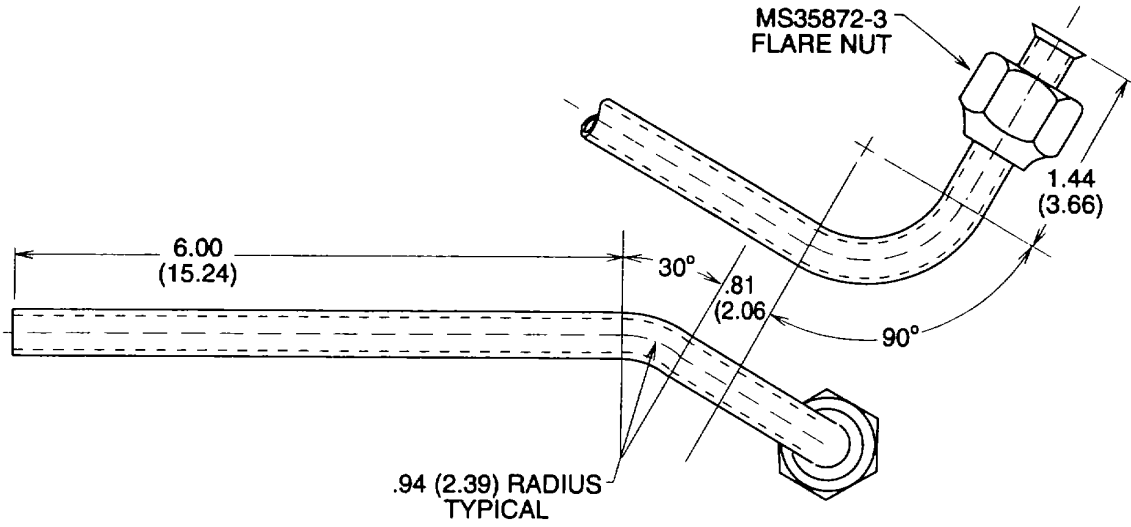

BLANK LENGTH 10.47 (26.59)

NOTE

1. FABRICATE FROM .375 (.952) O.D. X 0.032 (0.081) WALL ASTM B280 COPPER TUBING

Figure F-24. Tube, Tube to Expansion Valve, Part Number 152K0196

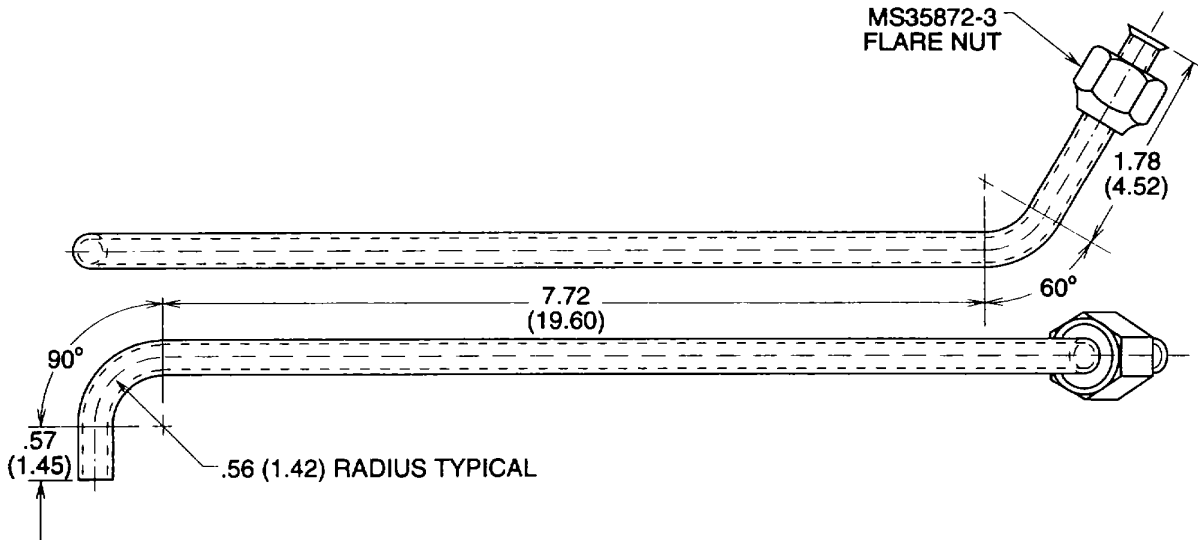

BLANK LENGTH 11.39 (28.93)

NOTE

1. FABRICATE FROM .375 (.952) O.D. X 0.032 (0.081) WALL ASTM B280 COPPER TUBING

Figure F-25. Tube Equalizer Line, Part Number 152K0197

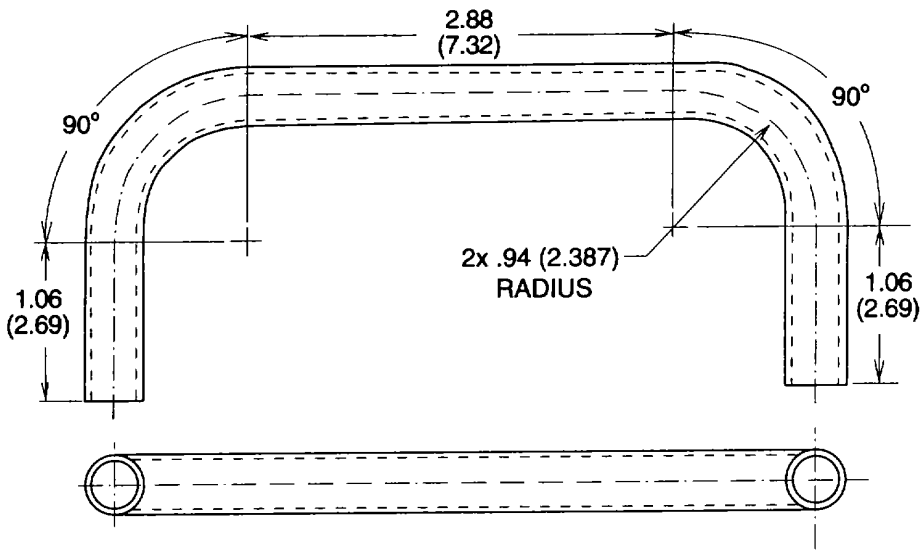

BLANK LENGTH 7.94 (20.17)

NOTE

1. FABRICATE FROM .375 (.952) O.D. X 0.032 (0.081) WALL ASTM B280 COPPER TUBING

Figure F-26. Tube, Tee to Distributor, Part Number 152K0198

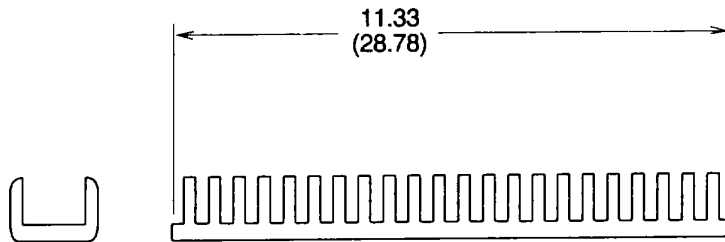

NOTE

1. FABRICATE FROM (03296) CATERPILLAR GROMMET FOR .015/.052 SHEET THICKNESS

Figure F-27. Grommet, Part Number 500K1662-2-11.33

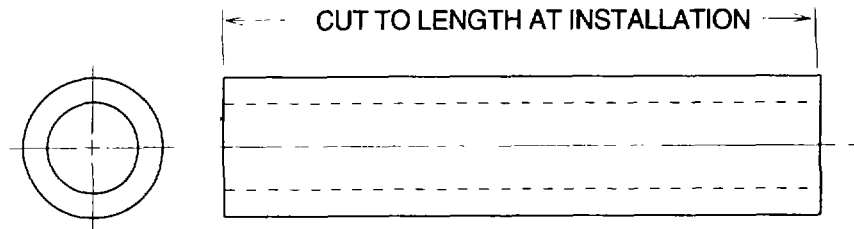
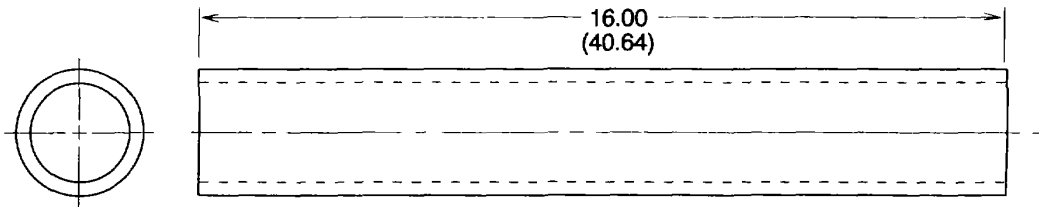

Figure F-28. Tubing, Insulation, Part Number 152K0000-1V57



NOTE

1. FABRICATE FROM ZZ-T-831 0.375 (0.953) INSIDE DIAMETER X 0.063 (0.160) WALL TYGON TUBING

Figure F-29. Tubing, Tygon, Part Number 152K0000-1155

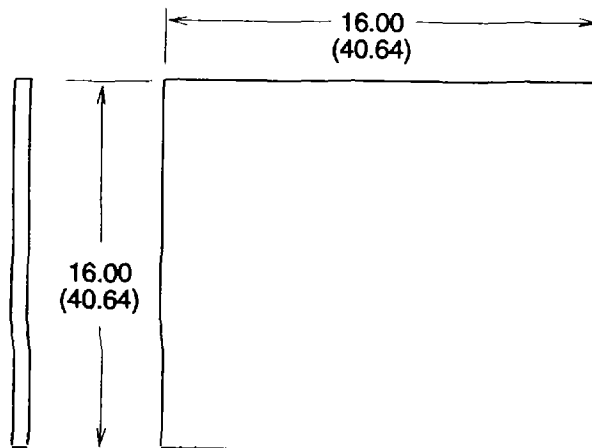

NOTE

1. FABRICATE FROM (97403) 13225E8562 INS

Figure F-30. Insulation Sound and Temperature, Part Number 152K00000-1/172

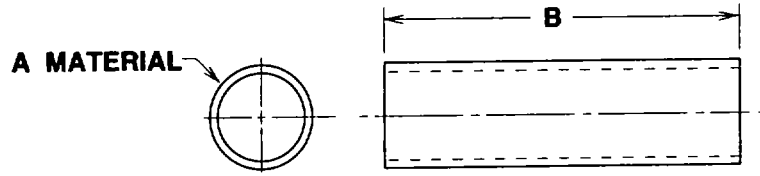

ITEM	PART NUMBER	FABRICATE FROM MATERIAL A	B LENGTH
1	150K0201-1/3	M23053/5-107-0 INSULATION, SLEEVING, HEAT SHRINKABLE	4.00 (10.16)
2	152K0000-1/191	M23053/5-106-9 INSULATION, SLEEVING, HEAT SHRINKABLE	1.50 (3.81)
3	152K0000-1/192	M23053/5-107-9 INSULATION, SLEEVING, HEAT SHRINKABLE	1.50 (3.81)
4	152K0009-1/54	M23053/5-107-9 INSULATION, SLEEVING, HEAT SHRINKABLE	.88 (2.24)
5	151K0042-1/4	M23053/5-102-0 INSULATION, SLEEVING, HEAT SHRINKABLE	1.50 (3.81)

Figure F-31. Insulation Sleeving

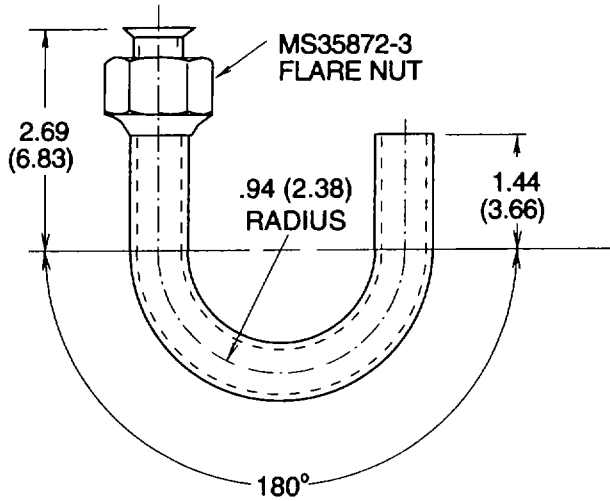

BLANK LENGTH 7.08 (17.98)

NOTE

- FABRICATE FROM .375 (.952) O.D. X 0.032 (0.812) WALL ASTM B280 COPPER TUBING

Figure F-32. Tube Assembly, Outlet, Handvalve To Sight Glass, Part Number 152K0180-1

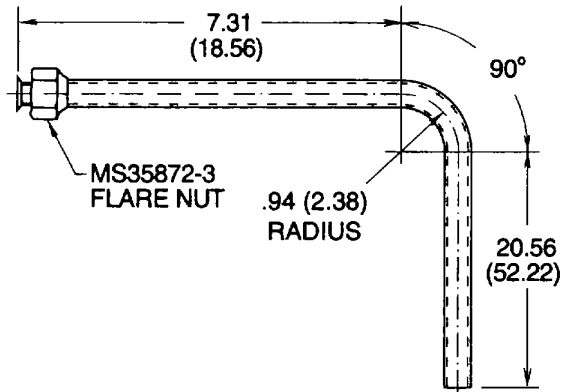

BLANK LENGTH 29.34 (74.52)

NOTE

1. FABRICATE FROM .375 (.952) O.D. X 0.032 (0.812) WALL ASTM B280 COPPER TUBING

Figure F-33. Tube Assembly, Outlet, Solenoid Valve (Defrost Line), Part Number 152K0182-1

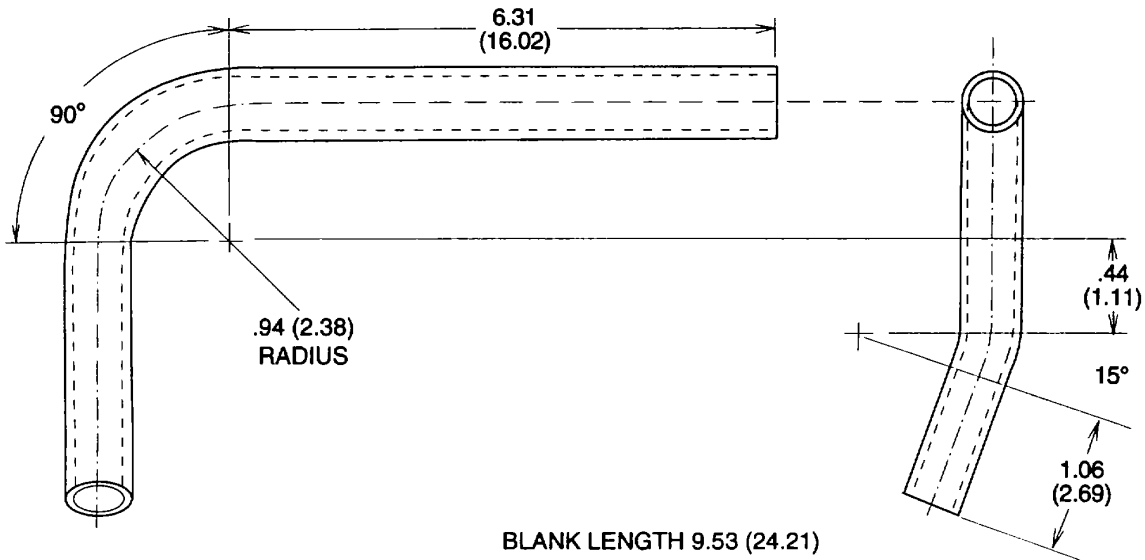

BLANK LENGTH 9.53 (24.21)

NOTE

1. FABRICATE FROM .375 (.952) O.D. X 0.032 (0.812) WALL ASTM B280 COPPER TUBING

Figure F-34. Tube, Heat Exchanger to Elbow, Part Number 152K0192

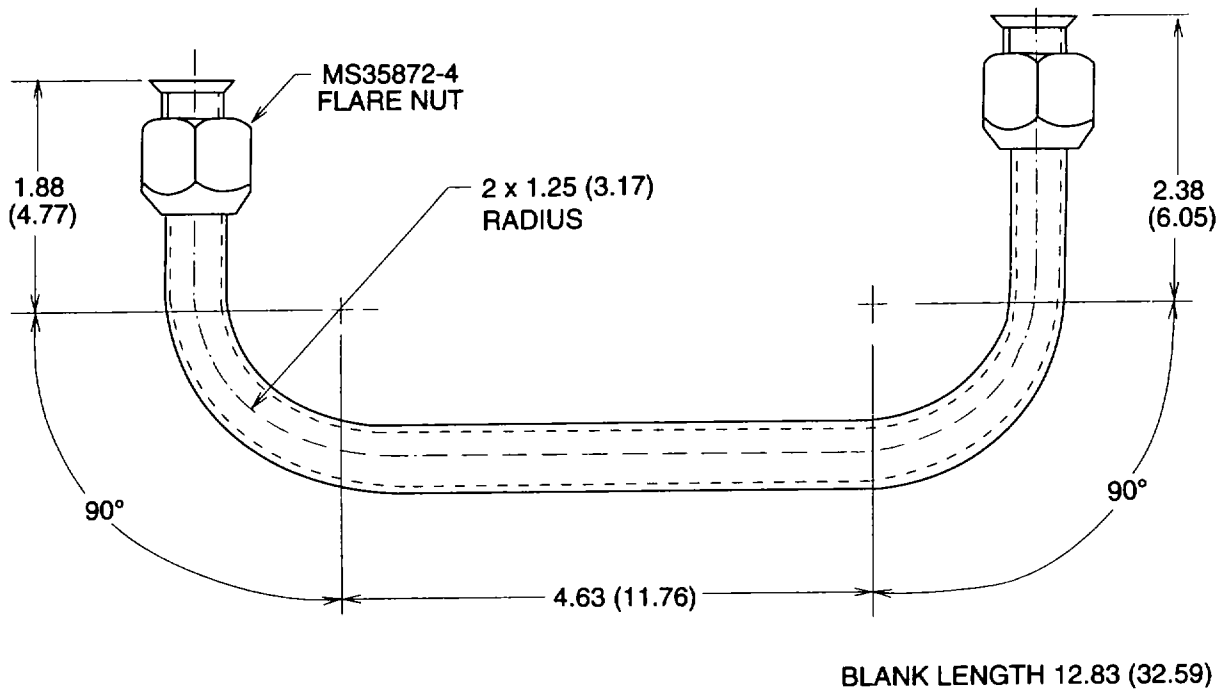

NOTE

1. FABRICATE FROM .500 (1.27) O.D. X 0.032 (0.081) WALL ASTM B280 COPPER TUBING

Figure F-35. Tube Assembly, Outlet, Receiver To Dehydrator, Part Number 152K0205-1

APPENDIX G

MANDATORY REPLACEMENT PARTS

Item Number	Nomenclature	Part Number	
1	Lock Washer	500K1950-3	(94833)
2	Seal	020-0844-01	(14569)
3	Lock Washer	500K1950-2	(94833)
4	Blind-Rivet Nut	NAS1329H08K130L	(80205)
5	Blind-Rivet Nut	NAS1329H3K130L	(80205)
6	Lock Washer	500K1950-1	(94833)
7	Lock Washer	500K1950-5	(94833)
8	Self Locking Nut	500K1927-1	(94833)
9	Terminal Mounting Plate Gasket	503-0346-01	(14569)
10	Oil Pump Gasket	020-0732-00	(14569)
11	Self Locking Nut	500K1927-4	(94833)
12	Self Locking Nut	500K1927-3	(94833)
13	Cotter Pin	MS24665-351	(96906)
14	Self Locking Nut	500K1927-2	(94833)
15	Self Locking Nut	500K1927-5	(94833)
16	Lock Washer	500K1950-6	(94833)
17	Self Locking Nut	500K1927-6	(94833)
18	Lock Washer	102-0010-11	(14569)
19	Locknut	101-0006-00	(14569)
20	Gasket	020-0012-11	(14569)
21	Gasket	020-0012-09	(14569)
22	Gasket	020-0756-00	(14569)

Item Number	Nomenclature	Part Number	
23	Gasket	020-0757-04	(14569)
24	Sight Glass	570-0020-00	(14569)
25	Lock Washer	102-0010-08	(14569)
26	Fused Cluster Terminal	521-0018-00	(14569)
27	Fused Cluster -Seal	020-0844-00	(14569)

ALPHABETICAL INDEX

A		D	
AC Motor B2 Testing And Replacement	4.34	Decals And Instruction Plates	2.8
Accumulator and Fusible Plug Replacement	5.24	Defrost Timer TM1 Testing And Replacement	4.29
Administrative Storage	4.46	Dehydrator Replacement.....	5.15
Air Handling System	1.14	Destruction Of Army Material To Prevent Enemy Use	1.3
Assembly And Preparation For Use	2.4	Differential Oil Pressure Switch S5 Replacement	5.32
Barrel Bolts Replacement	4.45	Discharging The Refrigerant System	5.8
Brazing/Debraze Procedure	5.10	Doors/Cover Repair And Replacement	5.42
Charging The Refrigerant System	5.13	Dual Pressure Control Switch S2 Replacement ...	5.33
Check Valve Replacement	5.21	E	
Circuit Breaker CB1 Testing And.....		Electric Heaters HR1, HR2, And HR3 Testing And Replacement	4.41
Replacement.....	4.22	Electrical System	1.13
Circuit Breaker Cover Repair	5.5	Equipment Characteristics, Capabilities And Features	1.10
Cleaning.....	3.4	Equipment Data	1.12
Compressor B1 Service, Testing, Repair, And.....		Evacuating The Refrigerant System	5.12
Replacement	5.39	Evaporator Coil Replacement.....	5.38
Condenser Coil Guard Replacement	4.17	Evaporator Fan Replacement	4.37
Condenser Coil Replacement.....	5.30	Expansion Valve Replacement	5.37
Condenser Enclosure Repair	5.40	F	
Condenser Fan Replacement	4.36	Fan drive Shaft Replacement	5.5
Contactora (Power Relay) K2 Testing And		Fault Controls And Indicators	2.2
Contactora (Power Relay) K2 Testing And		Flange Bearings Replacement	4.35
Replacement	4.26	Fuses FI And F2 Testing And Replacement	4.24
Contactora (Power Relay) K5 Testing And			
Replacement	4.27		
Control Box Cover Repair	5.3		
Control Relays K3 And K4 Testing And Replacement	4.28		
Corrosion Prevention And Control	1.9		

G	
Gasket Replacement	4.44
General	2.3, 3.3, 4.11
H	
Heat Exchanger Replacement	5.36
Hourmeter M1 Testing And Replacement	4.21
I	
Indicators/Lamps DS1, DS2, Or DS3 Testing And Replacement	4.19
Pressure Regulator Valve (Crankcase) Installation Instructions	4.7
Isolation Valves Replacement	5.17
L	
Leak Testing The Refrigerant System	5.11
Location And Description Of Major	
Components	1.11
Long Term Storage Or Shipment	4.48
Lubrication	3.1, 4.1, 4.10
M	
Maintenance Forms, Records And Reports	1.25
Mandatory Replacement Parts	4.12
Metal Hose Assembly (Discharge)..... Replacement	5.22
Metal Hose Assembly (Suction) Replacement	5.23
Motor Starter K1 Testing, Repair, And..... Replacement.....	4.25
N	
NBC Decontamination Procedures	2.10
O	
Official Nomenclature, Names And	t
Designations	1.6
Operating Controls And Indicators.....	2.1
Operating In Inclement Weather	2.9
Operator Checks	2.6

P	
Panels And Guard Repair	5.3
Plates (Data) Replacement	5.41
Preliminary Adjustment Of Equipment.....	4.9
Preliminary Servicing Of Equipment	4.8
Preparation For Storage Or Shipment	1.4
Pressure Gage (High) Replacement	5.35
Pressure Gage (Low) Replacement	5.34
Replacement	5.20
Pressure Regulator Valve (Discharge) Replacement	5.19
Pulley Replacement	4.32
Pump Down Refrigeration Unit	4.47
Purging The Refrigerant System	5.9
Push Switches S6 And S7 Testing And Replacement	4.30
Q	
Receiver and Fusible Plug Replacement	5.18
Refrigerant System Pressure Check	5.14
Refrigeration System Repairs.....	5.6
Reporting Equipment Improvement Recommendations (EIR)	1.7

S

Scope	1.1
Service Manifold Installation	5.7
Service Upon Receipt Of Material	4.6
Sheave Replacement.....	4.33
Shutdown Procedures	2.7
Side Panels (Evaporator) Replacement....	4.16
Sight Indicator Replacement	5.29
Site and Shelter Requirements.....	4.5
Solenoid Valve (Defrost Line) Repair And Solenoid Valve (Defrost Line) Repair And Replacement	5.25
Solenoid Valve L1 (Liquid Line) Testing And Repair	4.38
Solenoid Valve L2 (Defrost Line) Testing And Repair	4.39
Startup Procedures	2.5
Stop Valve (Defrost Line) Replacement ...	5.28
Stop Valve (Liquid Line) Replacement	5.27
Strainer Replacement	5.16

T

Temperature Switch S4 Replacement	4.43
Thermometer Testing And Replacement	4.40
Thermostat S3 Or Switch (Heater Lockout) S9 Testing And Replacement	4.23
Testing And Replacement	4.23
Thermostatic Switch S8 Testing And Replacement.....	4.42
Toggle Switch S1 Testing And Replacement ...	4.20
Top Access Panel Replacement.....	4.14
Top Panel (Evaporator) Replacement	4.15
Troubleshooting	3.2, 4.13, 5.1
Tubing And Fittings Testing, Repair, And Replacement	5.31
V-Belt Replacement And Adjustment	4.31

W

Warranty Information	1.8
Wires, Cables And Harnesses Testing, Repair, And Replacement.....	4.18

By Order of the Secretary of the Army:

Official:

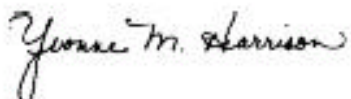

*Administrative Assistant to the
Secretary of the Army*

01281

DENNIS J. REIMER
*General, United States Army
Chief of Staff*

DISTRIBUTION:

To be distributed in accordance with DA Form 12-25-E, block no. 6320, requirements for TM 9-4110-258-13.

These are the instructions for sending an electronic 2028

The following format must be used if submitting an electronic 2028. The subject line must be exactly the same and all fields must be included; however only the following fields are mandatory: 1, 3, 4, 5, 6, 7, 8, 9, 10, 13, 15, 16, 17, and 27.

From: "Whomever" <whomever@avma27.army.mil>
To: amssbriml@natick.army.mil

Subject: DA Form 2028

1. From: Joe Smith
2. Unit: home
3. Address: 4300 Park
4. City: Hometown
5. St: MO
6. Zip: 77777
7. Date Sent: 19-OCT-93
8. Pub no: 55-2840-229-23
9. Pub Title: TM
10. Publication Date: 04-JUL-85
11. Change Number: 7
12. Submitter Rank: MSG
13. Submitter FName: Joe
14. Submitter MName: T
15. Submitter LName: Smith
16. Submitter Phone: 123-123-1234
17. Problem: 1
18. Page: 2
19. Paragraph: 3
20. Line: 4
21. NSN: 5
22. Reference: 6
23. Figure: 7
24. Table: 8
25. Item: 9
26. Total: 123
27. Text:

This is the text for the problem below line 27.

RECOMMENDED CHANGES TO PUBLICATIONS AND BLANK FORMS For use of this form, see AR 25-30; the proponent agency is ODISC4.						Use Part II (reverse) for Repair Parts and Special Tool Lists (RPSTL) and Supply Catalogs/Supply Manuals (SC/SM).	DATE 21 October 2003
TO: (Forward to proponent of publication or form) (Include ZIP Code) COMMANDER U.S. ARMY TANK-AUTOMOTIVE AND ARMAMENT COMMAND ATTN: AMSTA-LC-CECT 15 KANSAS STREET NATICK, MA 01760-5052						FROM: (Activity and location) (Include ZIP Code) <i>PFC Jane Doe</i> <i>CO A 3rd Engineer BR</i> <i>Ft. Leonardwood, MO 63108</i>	
PART I – ALL PUBLICATIONS (EXCEPT RPSTL AND SC/SM) AND BLANK FORMS							
PUBLICATION/FORM NUMBER TM 10-1670-296-23&P				DATE 30 October 2002	TITLE Unit Manual for Ancillary Equipment for Low Velocity Air Drop Systems		
ITEM NO.	PAGE NO.	PARA-GRAPH	LINE NO. *	FIGURE NO.	TABLE NO.	RECOMMENDED CHANGES AND REASON (Provide exact wording of recommended changes, if possible).	
	0036 00-2				1	<p><i>In table 1, Sewing Machine Code Symbols, the second sewing machine code symbol should be MD ZZ not MD 22.</i></p> <p><i>Change the manual to show Sewing Machine, Industrial: Zig-Zag; 308 stitch; medium-duty; NSN 3530-01-181-1421 as a MD ZZ code symbol.</i></p>	
<small>*Reference to line numbers within the paragraph or subparagraph.</small>							
TYPED NAME, GRADE OR TITLE Jane Doe, PFC				TELEPHONE EXCHANGE/AUTOVON, PLUS EXTENSION 508-233-4141		SIGNATURE Jane Doe <i>Jane Doe</i>	

TO: <i>(Forward direct to addressee listed in publication)</i> COMMANDER U.S. ARMY TANK-AUTOMOTIVE AND ARMAMENT COMMAND ATTN: AMSTA-LC-CECT 15 KANSAS STREET NATICK, MA 01760-5052	FROM: <i>(Activity and location) (Include ZIP Code)</i> <i>PFC Jane Doe</i> <i>CO A 3rd Engineer BR</i> <i>Ft. Leonardwood, MO 63108</i>	DATE <i>21 October 2003</i>
--	---	---------------------------------------

PART II – REPAIR PARTS AND SPECIAL TOOL LISTS AND SUPPLY CATALOGS/SUPPLY MANUALS

PUBLICATION NUMBER TM 10-1670-296-23&P	DATE 30 October 2002	TITLE Unit Manual for Ancillary Equipment for Low Velocity Air Drop Systems
--	--------------------------------	---

PAGE NO.	COLM NO.	LINE NO.	NATIONAL STOCK NUMBER	REFERENCE NO.	FIGURE NO.	ITEM NO.	TOTAL NO. OF MAJOR ITEMS SUPPORTED	RECOMMENDED ACTION
0066 00-1					4			<i>Callout 16 in figure 4 is pointed to a <u>D-Ring</u>. In the Repair Parts List key for figure 4, item 16 is called a <u>Snap Hook</u>. Please correct one or the other.</i>

SAMPLE

PART III – REMARKS *(Any general remarks or recommendations, or suggestions for improvement of publications and blank forms. Additional blank sheets may be used if more space is needed.)*

TYPED NAME, GRADE OR TITLE	TELEPHONE EXCHANGE/AUTOVON, PLUS EXTENSION	SIGNATURE
----------------------------	--	-----------

RECOMMENDED CHANGES TO PUBLICATIONS AND BLANK FORMS						Use Part II (reverse) for Repair Parts and Special Tool Lists (RPSTL) and Supply Catalogs/Supply Manuals (SC/SM).	DATE
For use of this form, see AR 25-30; the proponent agency is ODISC4.							
TO: (Forward to proponent of publication or form) (Include ZIP Code) COMMANDER U.S. ARMY TANK-AUTOMOTIVE AND ARMAMENT COMMAND ATTN: AMSTA-LC-CECT 15 KANSAS STREET NATICK, MA 01760-5052						FROM: (Activity and location) (Include ZIP Code)	
PART I – ALL PUBLICATIONS (EXCEPT RPSTL AND SC/SM) AND BLANK FORMS							
PUBLICATION/FORM NUMBER TM 9-4110-258-13				DATE 19 January 1996		TITLE Operator's, Unit and Direct Support Maintenance Manual for Refrigeration Unit, Mechanical, 9K BTU, Electric Model F9000RE	
ITEM NO.	PAGE NO.	PARA-GRAPH	LINE NO. *	FIGURE NO.	TABLE NO.	RECOMMENDED CHANGES AND REASON <i>(Provide exact wording of recommended changes, if possible).</i>	
<i>*Reference to line numbers within the paragraph or subparagraph.</i>							
TYPED NAME, GRADE OR TITLE				TELEPHONE EXCHANGE/AUTOVON, PLUS EXTENSION		SIGNATURE	

TO: (Forward direct to addressee listed in publication) COMMANDER U.S. ARMY TANK-AUTOMOTIVE AND ARMAMENT COMMAND ATTN: AMSTA-LC-CECT 15 KANSAS STREET NATICK, MA 01760-5052	FROM: (Activity and location) (Include ZIP Code)	DATE
---	---	-------------

PART II – REPAIR PARTS AND SPECIAL TOOL LISTS AND SUPPLY CATALOGS/SUPPLY MANUALS

PUBLICATION NUMBER TM 9-4110-258-13	DATE 19 January 1996	TITLE Operator's, Unit and Direct Support Maintenance Manual for Refrigeration Unit, Mechanical, 9K BTU, Electric Model F9000RE
--	-------------------------	---

PAGE NO.	COLM NO.	LINE NO.	NATIONAL STOCK NUMBER	REFERENCE NO.	FIGURE NO.	ITEM NO.	TOTAL NO. OF MAJOR ITEMS SUPPORTED	RECOMMENDED ACTION

PART III – REMARKS (Any general remarks or recommendations, or suggestions for improvement of publications and blank forms. Additional blank sheets may be used if more space is needed.)

TYPED NAME, GRADE OR TITLE	TELEPHONE EXCHANGE/AUTOVON, PLUS EXTENSION	SIGNATURE
----------------------------	--	-----------

<p align="center">RECOMMENDED CHANGES TO PUBLICATIONS AND BLANK FORMS</p> <p>For use of this form, see AR 25-30; the proponent agency is ODISC4.</p>						Use Part II (reverse) for Repair Parts and Special Tool Lists (RPSTL) and Supply Catalogs/Supply Manuals (SC/SM).	DATE
TO: (Forward to proponent of publication or form) (Include ZIP Code) COMMANDER U.S. ARMY TANK-AUTOMOTIVE AND ARMAMENT COMMAND ATTN: AMSTA-LC-CECT 15 KANSAS STREET NATICK, MA 01760-5052						FROM: (Activity and location) (Include ZIP Code)	
PART I – ALL PUBLICATIONS (EXCEPT RPSTL AND SC/SM) AND BLANK FORMS							
PUBLICATION/FORM NUMBER TM 9-4110-258-13				DATE 19 January 1996		TITLE Operator's, Unit and Direct Support Maintenance Manual for Refrigeration Unit, Mechanical, 9K BTU, Electric Model F9000RE	
ITEM NO.	PAGE NO.	PARA-GRAPH	LINE NO. *	FIGURE NO.	TABLE NO.	RECOMMENDED CHANGES AND REASON <i>(Provide exact wording of recommended changes, if possible).</i>	
<i>*Reference to line numbers within the paragraph or subparagraph.</i>							
TYPED NAME, GRADE OR TITLE				TELEPHONE EXCHANGE/AUTOVON, PLUS EXTENSION		SIGNATURE	

TO: <i>(Forward direct to addressee listed in publication)</i> COMMANDER U.S. ARMY TANK-AUTOMOTIVE AND ARMAMENT COMMAND ATTN: AMSTA-LC-CECT 15 KANSAS STREET NATICK, MA 01760-5052	FROM: <i>(Activity and location) (Include ZIP Code)</i>	DATE
--	--	-------------

PART II – REPAIR PARTS AND SPECIAL TOOL LISTS AND SUPPLY CATALOGS/SUPPLY MANUALS

PUBLICATION NUMBER TM 9-4110-258-13	DATE 19 January 1996	TITLE Operator's, Unit and Direct Support Maintenance Manual for Refrigeration Unit, Mechanical, 9K BTU, Electric Model F9000RE
--	-------------------------	---

PAGE NO.	COLM NO.	LINE NO.	NATIONAL STOCK NUMBER	REFERENCE NO.	FIGURE NO.	ITEM NO.	TOTAL NO. OF MAJOR ITEMS SUPPORTED	RECOMMENDED ACTION

PART III – REMARKS *(Any general remarks or recommendations, or suggestions for improvement of publications and blank forms. Additional blank sheets may be used if more space is needed.)*

TYPED NAME, GRADE OR TITLE	TELEPHONE EXCHANGE/AUTOVON, PLUS EXTENSION	SIGNATURE
----------------------------	--	-----------

RECOMMENDED CHANGES TO PUBLICATIONS AND BLANK FORMS						Use Part II (reverse) for Repair Parts and Special Tool Lists (RPSTL) and Supply Catalogs/Supply Manuals (SC/SM).	DATE
For use of this form, see AR 25-30; the proponent agency is ODISC4.							
TO: (Forward to proponent of publication or form) (Include ZIP Code) COMMANDER U.S. ARMY TANK-AUTOMOTIVE AND ARMAMENT COMMAND ATTN: AMSTA-LC-CECT 15 KANSAS STREET NATICK, MA 01760-5052						FROM: (Activity and location) (Include ZIP Code)	
PART I – ALL PUBLICATIONS (EXCEPT RPSTL AND SC/SM) AND BLANK FORMS							
PUBLICATION/FORM NUMBER TM 9-4110-258-13				DATE 19 January 1996		TITLE Operator's, Unit and Direct Support Maintenance Manual for Refrigeration Unit, Mechanical, 9K BTU, Electric Model F9000RE	
ITEM NO.	PAGE NO.	PARA-GRAPH	LINE NO. *	FIGURE NO.	TABLE NO.	RECOMMENDED CHANGES AND REASON <i>(Provide exact wording of recommended changes, if possible).</i>	
<i>*Reference to line numbers within the paragraph or subparagraph.</i>							
TYPED NAME, GRADE OR TITLE				TELEPHONE EXCHANGE/AUTOVON, PLUS EXTENSION		SIGNATURE	

TO: (Forward direct to addressee listed in publication) COMMANDER U.S. ARMY TANK-AUTOMOTIVE AND ARMAMENT COMMAND ATTN: AMSTA-LC-CECT 15 KANSAS STREET NATICK, MA 01760-5052	FROM: (Activity and location) (Include ZIP Code)	DATE
---	---	-------------

PART II – REPAIR PARTS AND SPECIAL TOOL LISTS AND SUPPLY CATALOGS/SUPPLY MANUALS

PUBLICATION NUMBER TM 9-4110-258-13	DATE 19 January 1996	TITLE Operator's, Unit and Direct Support Maintenance Manual for Refrigeration Unit, Mechanical, 9K BTU, Electric Model F9000RE
--	-------------------------	---

PAGE NO.	COLM NO.	LINE NO.	NATIONAL STOCK NUMBER	REFERENCE NO.	FIGURE NO.	ITEM NO.	TOTAL NO. OF MAJOR ITEMS SUPPORTED	RECOMMENDED ACTION

PART III – REMARKS (Any general remarks or recommendations, or suggestions for improvement of publications and blank forms. Additional blank sheets may be used if more space is needed.)

TYPED NAME, GRADE OR TITLE	TELEPHONE EXCHANGE/AUTOVON, PLUS EXTENSION	SIGNATURE
----------------------------	--	-----------

The Metric System and Equivalents

Linear Measure

1 centimeter = 10 millimeters = .39 inch
 1 decimeter = 10 centimeters = 3.94 inches
 1 meter = 10 decimeters = 39.37 inches
 1 dekameter = 10 meters = 32.8 feet
 1 hectometer = 10 dekameters = 328.08 feet
 1 kilometer = 10 hectometers = 3,280.8 feet

Weights

1 centigram = 10 milligrams = .15 grain
 1 decigram = 10 centigrams = 1.54 grains
 1 gram = 10 decigram = .035 ounce
 1 decagram = 10 grams = .35 ounce
 acres
 1 hectogram = 10 decagrams = 3.52 ounces
 1 kilogram = 10 hectograms = 2.2 pounds
 1 quintal = 100 kilograms = 220.46 pounds
 1 metric ton = 10 quintals = 1.1 short tons

Liquid Measure

1 centiliter = 10 milliliters = .34 fl. ounce
 1 deciliter = 10 centiliters = 3.38 fl. ounces
 1 liter = 10 deciliters = 33.81 fl. ounces
 1 dekaliter = 10 liters = 2.64 gallons
 1 hectoliter = 10 dekaliters = 26.42 gallons
 1 kiloliter = 10 hectoliters = 264.18 gallons

Square Measure

1 sq. centimeter = 100 sq. millimeters = .155 sq. inch
 1 sq. decimeter = 100 sq. centimeters = 15.5 sq. inches
 1 sq. meter (centare) = 100 sq. decimeters = 10.76 sq. feet
 1 sq. dekameter (are) = 100 sq. meters = 1,076.4 sq. feet
 1 sq. hectometer (hectare) = 100 sq. dekameters = 2.47
 1 sq. kilometer = 100 sq. hectometers = .386 sq. mile

Cubic Measure

1 cu. centimeter = 1000 cu. millimeters = .06 cu. inch
 1 cu. decimeter = 1000 cu. centimeters = 61.02 cu. inches
 1 cu. meter = 1000 cu. decimeters = 35.31 cu. feet

Approximate Conversion Factors

<i>To change</i>	<i>To</i>	<i>Multiply by</i>	<i>To change</i>	<i>To</i>	<i>Multiply by</i>
inches	centimeters	2.540	ounce-inches	Newton-meters	.007062
feet	meters	.305	centimeters	inches	.394
yards	meters	.914	meters	feet	3.280
miles	kilometers	1.609	meters	yards	1.094
square inches	square centimeters	6.451	kilometers	miles	.621
square feet	square meters	.093	square centimeters	square inches	.155
square yards	square meters	.836	square meters	square feet	10.764
square miles	square kilometers	2.590	square meters	square yards	1.196
acres	square hectometers	.405	square kilometers	square miles	.386
cubic feet	cubic meters	.028	square hectometers	acres	2.471
cubic yards	cubic meters	.765	cubic meters	cubic feet	35.315
fluid ounces	milliliters	29,573	cubic meters	cubic yards	1.308
pints	liters	.473	milliliters	fluid ounces	.034
quarts	liters	.946	liters	pints	2.113
gallons	liters	3.785	liters	quarts	1.057
ounces	grams	28.349	liters	gallons	.264
pounds	kilograms	.454	grams	ounces	.035
short tons	metric tons	.907	kilograms	pounds	2.205
pound-feet	Newton-meters	1.356	metric tons	short tons	1.102
pound-inches	Newton-meters	.11296			

Temperature (Exact)

°F	Fahrenheit	5/9 (after	Celsius	°C
	temperature	subtracting 32)	temperature	

